

ERSATZTEILLISTE

ECHO Motorsense

SRM-2015

ECHO-Motorgeräte
Vertrieb Deutschland GmbH
Otto-Schott-Str. 7

72555 Metzingen

Telefon 07123-1091
Telefax 07123-2589
<http://www.echo-shop.de>
email: info@echo-shop.de



Bild	Artikelnummer	Anzahl	Beschreibung	Anmerkung	Bild	Artikelnummer	Anzahl	Beschreibung	Anmerkung
1	101011-06560	1	CYLINDER	Sus. by 101011-06562	11	100204-52130	1	CRANKCASE KIT	
1	101011-06561	1	CYLINDER	Sus. by 101011-06562	12	+ 100212-42030	2	OILSEAL	
1	101011-06562	1	CYLINDER		13	+ 100215-03930	2	PIN, DOWEL	
2	900162-05022	2	BOLT, H.S. 5*22		14	+ 900810-36201	2	BEARING, BALL 6201	Sus. by 94035-36201
3	101010-44332	1	GASKET, CYL. BASE		14	+ 94035-36201	2	BEARING, BALL	
4	100000-48730	1	PISTON KIT	Sus. by 100000-48732	15	+ 100242-42030	1	GASKET, CRANKCASE	
4	100000-48731	1	PISTON KIT	Sus. by 100000-48732	16	+ 900162-05028	3	BOLT, H.S. 5*28	
4	100000-48732	1	PISTON KIT		17	101514-44731	1	COVER, CYLINDER	Sus. by 101514-42031
5	+ 100011-05330	2	RING, PISTON		17	101514-42031	1	COVER, CYLINDER	
6	+ 100013-11520	1	PIN, PISTON		18	900238-04012	2	SCREW 4*12	
7	+ 100015-04630	2	CIRCLIP, PISTON PIN		19	101511-44630	1	COVER, FAN (BS)	
8	+ 100014-11520	2	SPACER, PISTON PIN		20	900238-04016	6	SCREW 4*16	
9	100100-54130	1	CRANKSHAFT ASY	Sus. by 100100-44733	21	900151-05025	1	BOLT 5*25	
9	100100-44732	1	CRANKSHAFT ASY	Sus. by 100100-44733	22	900605-00005	1	WASHER, SPRING 5	
9	100100-44733	1	CRANKSHAFT ASY		23	900600-00005	1	WASHER 5	
10	+ 100012-51230	1	BEARING, NEEDLE	Sus. by V553-000030	24	890611-46730	1	LABEL, MODEL	SRM-2015
10	+ V553-000030	1	BEARING, NEEDLE 8		24	X543-000110	1	LABEL, MODEL	SRM-2015S



Bild	Artikelnummer	Anzahl	Beschreibung	Anmerkung
1	175053-04920	1	STOPPER	
2	900701-00012	1	CIRCLIP 12	
3	900814-06201	1	BEARING, BALL 6201	
4	900702-00032	1	CIRCLIP 32	
5	175005-46730	1	DRUM, CLUTCH	
6	175000-52130	1	CLUTCH ASY	
7	156801-44731	1	FLYWHEEL	Sus. by 156801-44731
7	156801-12360	1	FLYWHEEL	Sus. by 156801-44731
7	156801-44731	1	FLYWHEEL	
8	156601-52130	1	COIL, IGNITION	
9	900162-04022	2	BOLT, H.S. 4*22	
10	162021-52130	1	LEAD	Sus. by 162010-52830
10	162010-52830	1	LEAD, GROUND	
11	159012-01620	1	CAP, SPARK PLUG	
12	159011-03432	1	COIL, SPARK PLUG CAP	
13	159017-10230	1	PLUG, SPARK (RCJ-7Y)	
14	150112-42030	1	BUSHING	

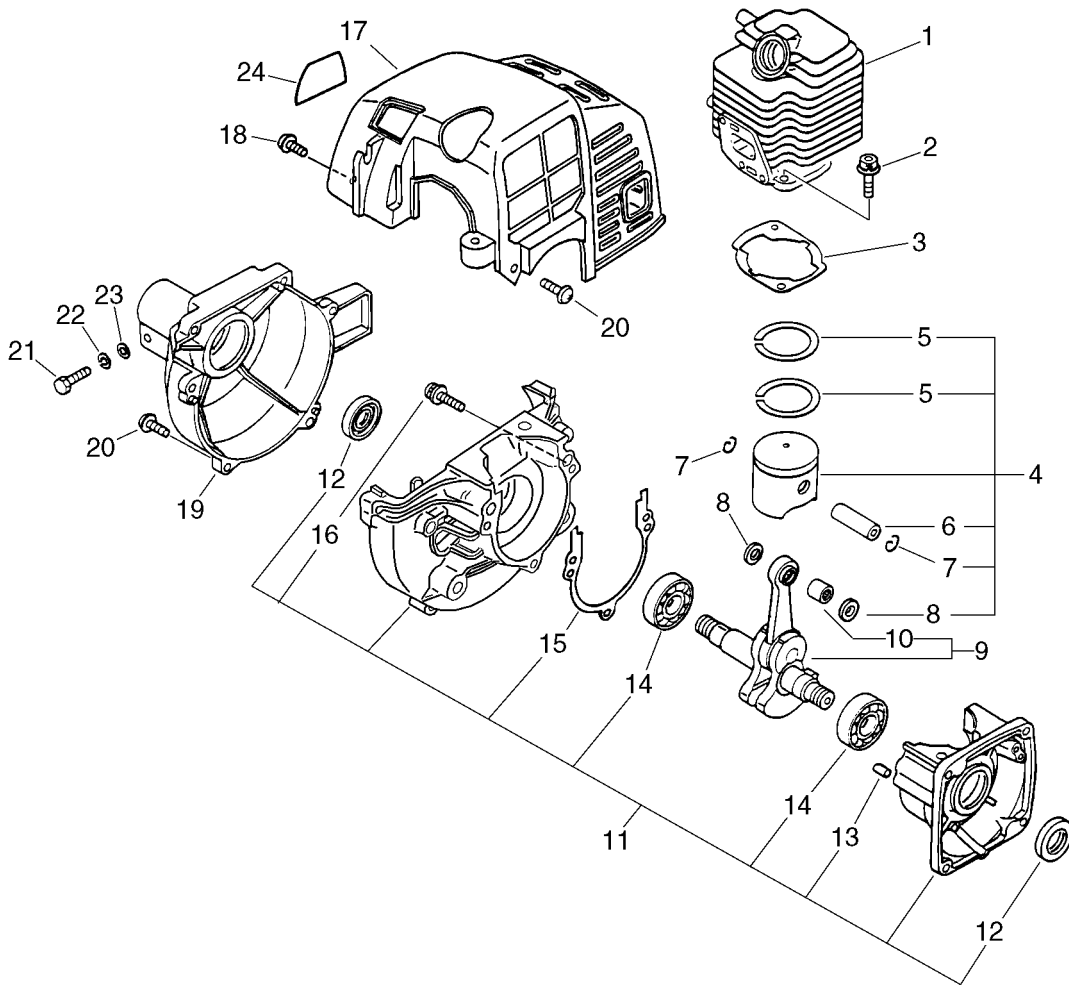

Bild		Artikelnummer	Anzahl	Beschreibung	Anmerkung
21		177202-44330	1	PAWL ASY, STARTER	SRM-2015
22	+	177234-42030	1	SPRING, RETURN	SRM-2015
23	+	177218-44330	1	PAWL, STARTER	SRM-2015
24		177200-42033	1	STARTER ASY	SRM-2015
25	+	177236-44330	1	SCREW	SRM-2015
26	+	177215-44430	1	DRUM, STARTER	SRM-2015
27	+	177226-10120	1	ROPE, STARTER	SRM-2015
28	+	177227-42030	1	GUIDE, ROPE	SRM-2015
29	+	177228-06530	1	GRIP, STARTER	SRM-2015
30	+	177220-42030	1	SPRING, REWIND	SRM-2015
35		900238-04016	2	SCREW 4*16	SRM-2015
36		890118-49130	1	LABEL, ECHO	SRM-2015

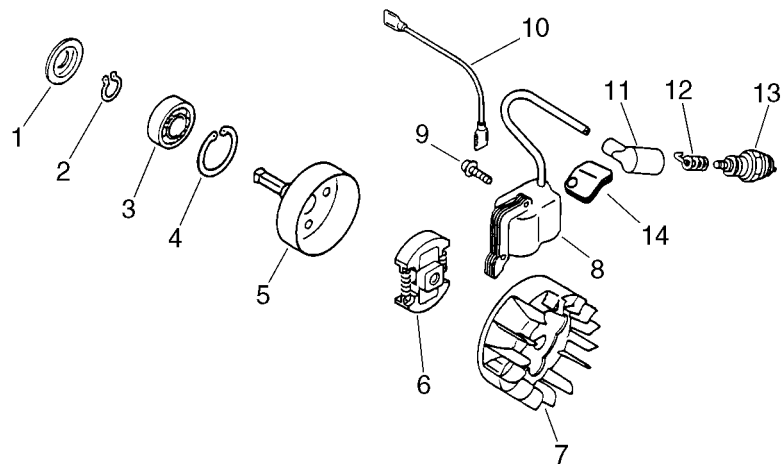

Bild		Artikelnummer	Anzahl	Beschreibung	Anmerkung
15		900253-05020	3	SCREW 5*20	SRM-2015SI
18		X502-000031	1	LABEL,ECHO	SRM-2015SI
19		A051-000290	1	STARTER,RECOIL	SRM-2015SI
20	+	177246-11120	1	CLIP, STARTER ROPE	SRM-2015SI
21	+	177228-27030	1	GRIP, STARTER	SRM-2015SI
22	+	P022-004610	2	SPRING, RETURN	SRM-2015SI
23	+	P022-004620	2	PAWL, STARTER	SRM-2015SI
24	+	P022-004680	1	SPRING, SPIRAL	SRM-2015SI
25	+	P022-004600	1	ROPE,STARTER	SRM-2015SI
26	+	P022-004690	1	REEL,ROPE	SRM-2015SI
27	+	P022-004660	1	SPRING, RETURN	SRM-2015SI
28	+	P022-004670	1	PAWL, STARTER	SRM-2015SI
29	+	P022-004650	1	COMPLETE,SPRING	SRM-2015SI
30	+	P022-004640	1	PLATE,CAM	SRM-2015SI
31	+	P022-004630	1	SCREW	SRM-2015SI
33		900162-04016	2	BOLT, H.S. 4*16	SRM-2015SI
35		V376-000360	1	SPACER	SRM-2015SI
40		A052-000130	1	PULLEY,ASM STARTER	SRM-2015SI
41	+	P022-004740	2	PAWL,STARTER	SRM-2015SI
42	+	177234-42030	2	SPRING, RETURN	SRM-2015SI
43	+	P022-002100	2	E-RING	SRM-2015SI

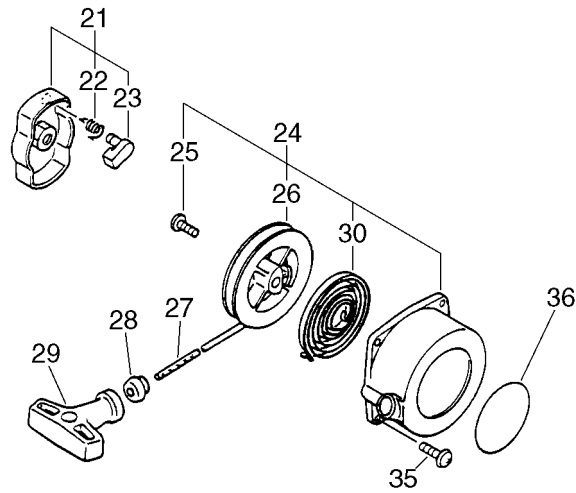

Bild	Artikelnummer	Anzahl	Beschreibung	Anmerkung
1	130010-42032	1	GASKET,INTAKE	
2	900500-00005	2	NUT 5	
3	900238-05020	2	SCREW 5*20	
4	130017-42031	1	INSULATOR	
5	130016-42031	1	GASKET, INTAKE	
6	125200-52430	1	CARBURETOR ASSY	Sus. by 125200-52431
6	125200-52431	1	CARBURETOR ASSY	
7	130319-42030	1	FIXTURE,AIR CLEANER	
8	130301-42030	1	CASE, AIR CLEANER	
9	+ 178810-42030	1	GROMMET	
10	178515-42030	1	SHUTTER, CHOKE	Sus.by 178515-46731
10	178515-46731	1	SHUTTER, CHOKE	
11	178516-00830	2	SPACER	
12	900242-05057	2	SCREW 5*57	
13	130310-46730	1	FILTER, AIR	
14	890169-47530	1	LABEL, ADJUSTING	
21	P021-000050	1	MUFFLER ASY	
22	+ 145510-42031	2	GASKET, MUFFLER	Sus.by V104-000160
22	+ V104-000160	2	GASKET,EXHAUST	
23	+ 145866-42031	1	GASKET, MUFFLER LID	
24	+ 145863-42030	1	HOLDER, SCREEN	
25	+ 145876-42030	1	LID, MUFFLER (B)	
26	+ 900242-04010	3	SCREW 4*10	
27	900105-05055	2	BOLT, H.S. 5*55	
28	900600-00005	2	WASHER 5	Sus. by 145642-04930
28	145642-04930	1	WASHER	
29	145631-42030	1	COVER, MUFFLER	

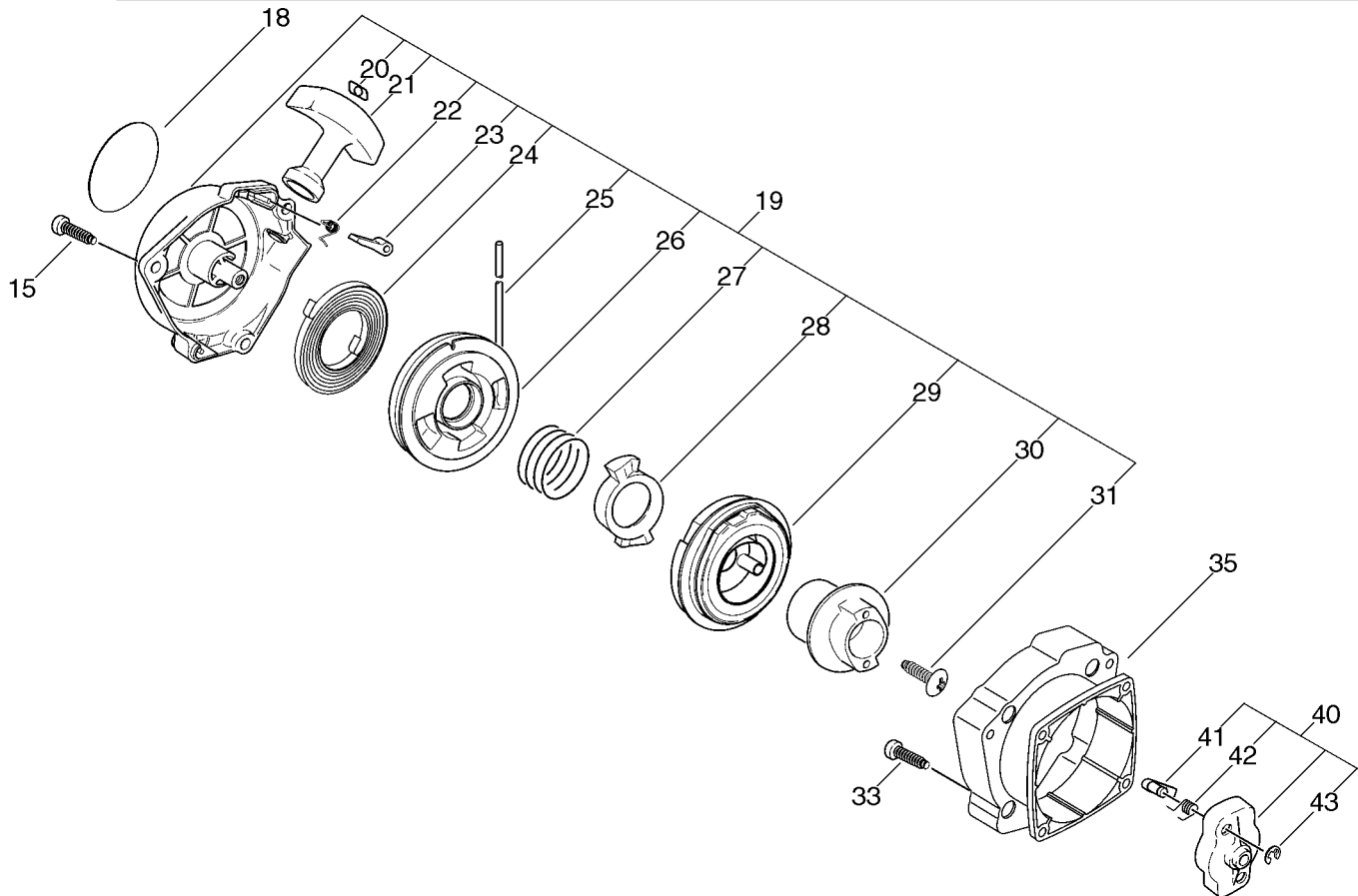

Bild	Artikelnummer	Anzahl	Beschreibung	Anmerkung
1	131005-44331	1	TANK, FUEL	
2	900243-05016	2	SCREW 5*16	
3	305110-42030	1	STAND (BL)	
4	131004-55530	1	CAP ASSY, FUEL TANK	
5	+ 131016-55830	1	GASKET, FUEL CAP	
6	+ 131051-56030	1	CLIP, FUEL CAP	
7	131300-56430	1	VALVE, CHECK	
8	130111-00530	1	CLIP	
9	131312-44330	1	PIPE, 3*5*70L	
10	132115-46730	1	GROMMET, FUEL	
11	132013-09820	1	CLIP	
12	131205-07320	1	STRAINER, FUEL	
13	132010-56330	1	PIPE 3*6*90	
14	132010-13930	1	PIPE, FUEL	

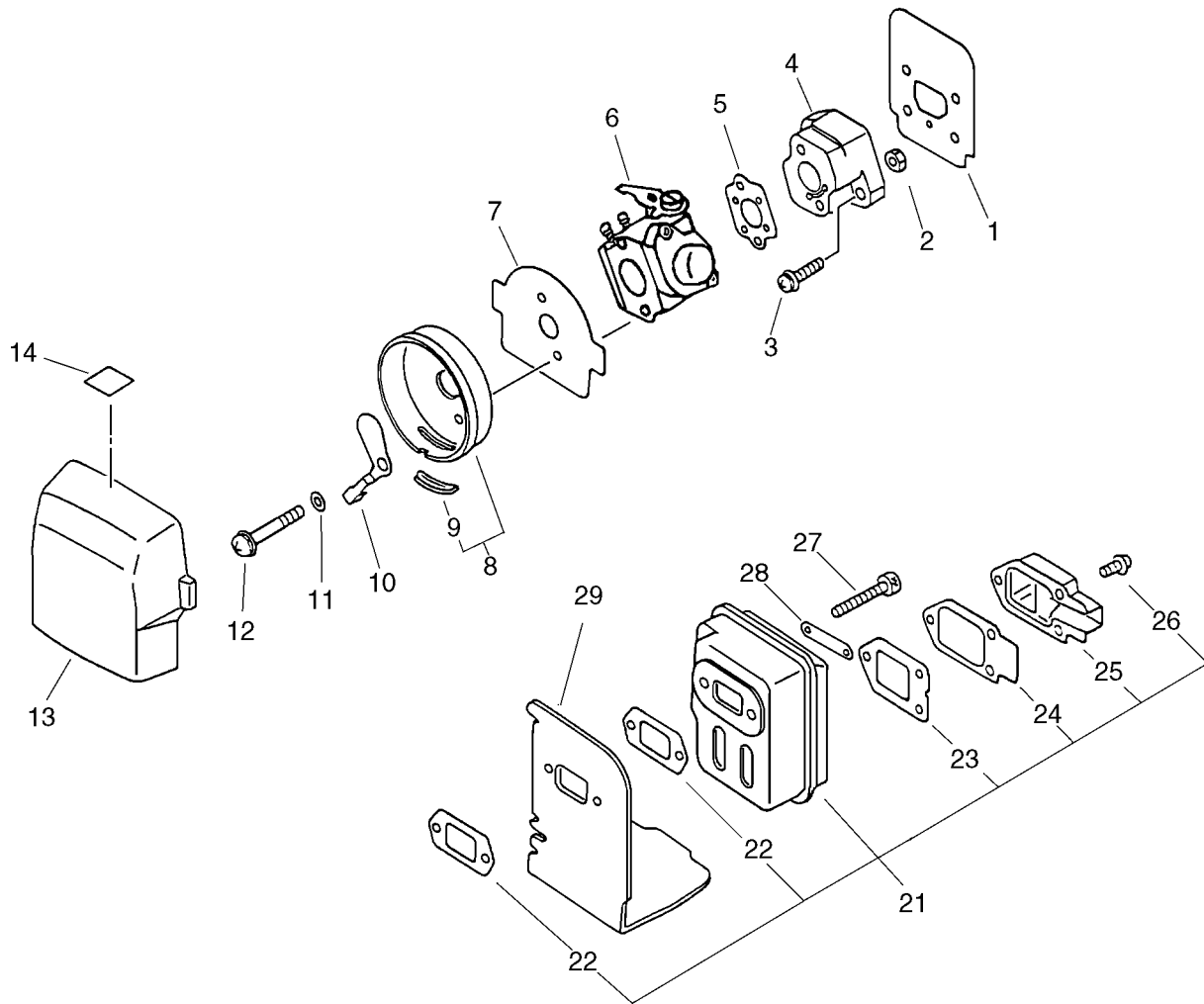

Bild	Artikelnummer	Anzahl	Beschreibung	Anmerkung	
Sr/Nr 035852 and before /SRM -2015					
25	699000-52930	1	SHIELD ASY	Sus. by 699000-52931	
25	699000-52931	1	SHIELD ASY	Sr/Nr 035852 and before /SRM-2015	
26	+	699013-52130	1	PLATE, SHIELD	Sr/Nr 035852 and before /SRM-2015
27	+	900162-05018	4	BOLT, H.S. 5*18	Sr/Nr 035852 and before /SRM-2015
28	+	900162-05014	2	BOLT, H.S. 5*14	Sr/Nr 035852 and before /SRM-2015
29	+	900162-05025	4	BOLT, H.S. 5*25	
30	+	699013-56830	1	PLATE, SHIELD	
31	+	699016-52130	1	KNIFE, CORD	Sus. by 699016-54530
31	+	699016-54530	1	KNIFE, CORD	Sr/Nr 035852 and before /SRM-2015
32	+	900603-00005	4	WASHER 5	Sr/Nr 035852 and before /SRM-2015
33	+	900500-00005	6	NUT 5	Sr/Nr 035852 and before /SRM-2015
34	+	699010-52930	1	SHIELD, BLADE	Sus. by 699010-52931
34	+	699010-52931	1	SHIELD, BLADE	Sr/Nr 035852 and before /SRM-2015

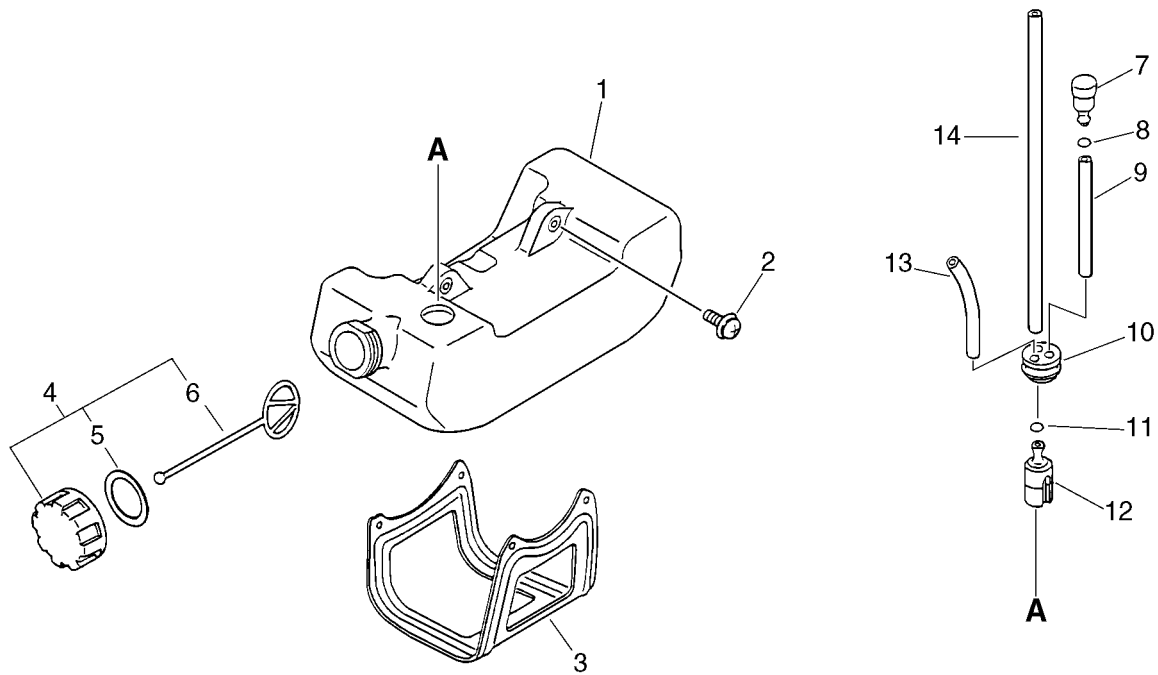

Bild	Artikelnummer	Anzahl	Beschreibung	Anmerkung
Sr/Nr 035853 and after/SRM -2015 SRM -2015SI				
1	895610-00130	1	L-WRENCH (4MM)	
2	895112-00330	1	SPANNER 8*10	
3	895410-08030	1	WRENCH, W/S. DRIVER	
4	897518-01131	1	LOCKING TOOL	
5	899580-40930	1	GOGGLE	Sus. by 899580-68730
5	899580-68730	1	SAFETY GLASSES	
6	898510-39130	1	BAG, TOOL	
10	P021-002620	1	SHIELD, BLADE (W/KNIFE)	Sr/Nr 035853 and after/SRM-2015
10	P021-002620	1	SHIELD, BLADE (W/KNIFE)	SRM-2015SI
11	+ C550-000080	1	SHIELD, BLADE	Sr/Nr 035853 and after/SRM-2015
11	+ C550-000080	1	SHIELD, BLADE	SRM-2015SI
12	+ C554-000000	1	KNIFE, CORD	Sr/Nr 035853 and after/SRM-2015
12	+ C554-000000	1	KNIFE, CORD	SRM-2015SI
13	+ 900252-05012	1	SCREW 5*12	Sr/Nr 035853 and after/SRM-2015
13	+ 900252-05012	1	SCREW 5*12	SRM-2015SI
16	900565-00005	1	NUT	Sr/Nr 035853 and after/SRM-2015
16	900565-00005	1	NUT	SRM-2015SI
17	900242-05018	1	SCREW 5*18	Sr/Nr 035853 and after/SRM-2015
17	900242-05018	1	SCREW 5*18	SRM-2015SI
20	C550-000100	1	SHIELD, BLADE	Sr/Nr 035853 and after/SRM-2015
20	C550-000100	1	SHIELD, BLADE	SRM-2015SI
21	C550-000090	1	SHIELD, BLADE	Sr/Nr 035853 and after/SRM-2015
21	C550-000090	1	SHIELD, BLADE	SRM-2015SI
22	699013-56830	1	PLATE, SHIELD	
23	900162-05025	4	BOLT, H.S. 5*25	

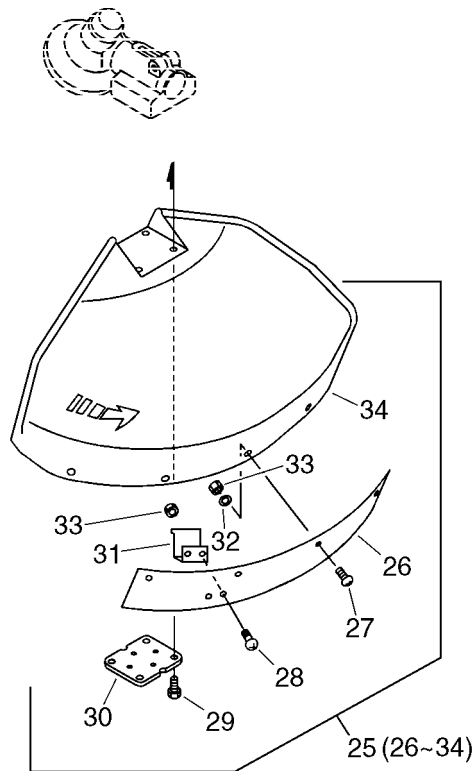

Bild	Artikelnummer	Anzahl	Beschreibung	Anmerkung	Bild	Artikelnummer	Anzahl	Beschreibung	Anmerkung
1	351102-47530	1	GRIP ASY, F-HANDLE	Sr/Nr 035852 and before/SRM-2015	14	224924-52130	2	CLIP	
1	P021-002610	1	GRIP ASY,F-HANDLE	Sr/Nr 035853 and after/SRM-2015	15	301200-21330	1	HOOK ASY	
1	P021-002610	1	GRIP ASY,F-HANDLE	SRM-2015SI	16 +	301015-05330	1	HOOK, BAND	
2 +	900246-03025	4	SCREW 3*25	Sr/Nr 035852 and before/SRM-2015	17 +	301205-21330	1	HOOK	
2 +	900246-04016	3	SCREW 4*16	Sus. by 900253-04016	18 ++	900105-05012	1	BOLT, H.S. 5*12	
2 +	900253-04016	3	SCREW 4*16	Sr/Nr 035853 and after/SRM-2015	19	351301-52130	1	BRACKET ASY, HANDLE	Sr/Nr 037062 and before/SRM-2015
2 +	900253-04016	3	SCREW 4*16	SRM-2015SI	19	P021-002750	1	BRACKET ASY, HANDLE	Sr/Nr 037063 and after/SRM-2015
3 +	900220-05030	1	SCREW 5*30		19	P021-002750	1	BRACKET ASY, HANDLE	SRM-2015SI
4 +	900500-00005	1	NUT 5		20 +	900565-50008	1	NUT	
5	178012-05960	1	LOCKOUT, THROTTLE	Sr/Nr 035852 and before/SRM-2015	21 +	900162-05030	3	BOLT, H.S. 5*30	
5	C460-000010	1	LOCKOUT,THROTTLE	Sr/Nr 035853 and after/SRM-2015	22 +	900162-05020	2	BOLT, H.S. 5*20	Sr/Nr 037062 and before/SRM-2015
5	C460-000010	1	LOCKOUT,THROTTLE	SRM-2015SI	23 +	605014-54230	1	WASHER	
6	178013-35631	1	SPRING, THR. LOCK	Sr/Nr 035852 and before/SRM-2015	24 +	351421-52130	1	BOLT	Sr/Nr 037062 and before/SRM-2015
6	V452-000050	1	SPRING,TORSION	Sr/Nr 035853 and after/SRM-2015	24 +	V299-000110	1	KNOB,FASTENER	Sr/Nr 037063 and after/SRM-2015
6	V452-000050	1	SPRING,TORSION	SRM-2015SI	24 +	V299-000110	1	KNOB,FASTENER	SRM-2015SI
7	178010-05960	1	CONTROL, THROTTLE	Sr/Nr 035852 and before/SRM-2015	25	351214-52130	1	HANDLE, FRONT	Sus. by C400-000000
7	C450-000020	1	TRIGGER,THROTTLE	Sr/Nr 035853 and after/SRM-2015	25	C400-000000	1	HANDLE, FRONT	
7	C450-000020	1	TRIGGER,THROTTLE	SRM-2015SI	26	351311-02330	1	GRIP, HANDLE	Sr/Nr 035852 and before/SRM-2015
8	V452-000060	1	SPRING,TORSION	Sr/Nr 035853 and after/SRM-2015	26	C403-000030	1	GRIP,HANDLE	Sr/Nr 035853 and after/SRM-2015
8	V452-000060	1	SPRING,TORSION	SRM-2015SI	26	C403-000030	1	GRIP,HANDLE	SRM-2015SI
9	163401-49230	1	SWITCH, IGNITION		27	890617-46830	1	LABEL, CAUTION	Sus. by 890617-43130
10	900502-00006	2	NUT 6 (3N)		27	890617-43130	1	LABEL, CAUTION	
11	178001-47530	1	WIRE, THROTTLE	Sr/Nr 035852 and before/SRM-2015	28	610206-28230	1	HOUSING ASY D,SFT.	
11	V430-000410	1	CABLE,BOWDEN	Sr/Nr 035853 and after/SRM-2015	29	610018-27830	1	SHAFT, DRIVE	
11	V430-000410	1	CABLE,BOWDEN	SRM-2015SI	30	301001-56830	1	HARNES, SHOULDER	Sus. by 301001-56831
12	178127-47530	1	TUBE		30	301001-56831	1	HARNES, SHOULDER	
13	159112-09960	1	CLIP		31	890157-39130	1	LABEL, SWITCH	Sr/Nr 035852 and before/SRM-2015

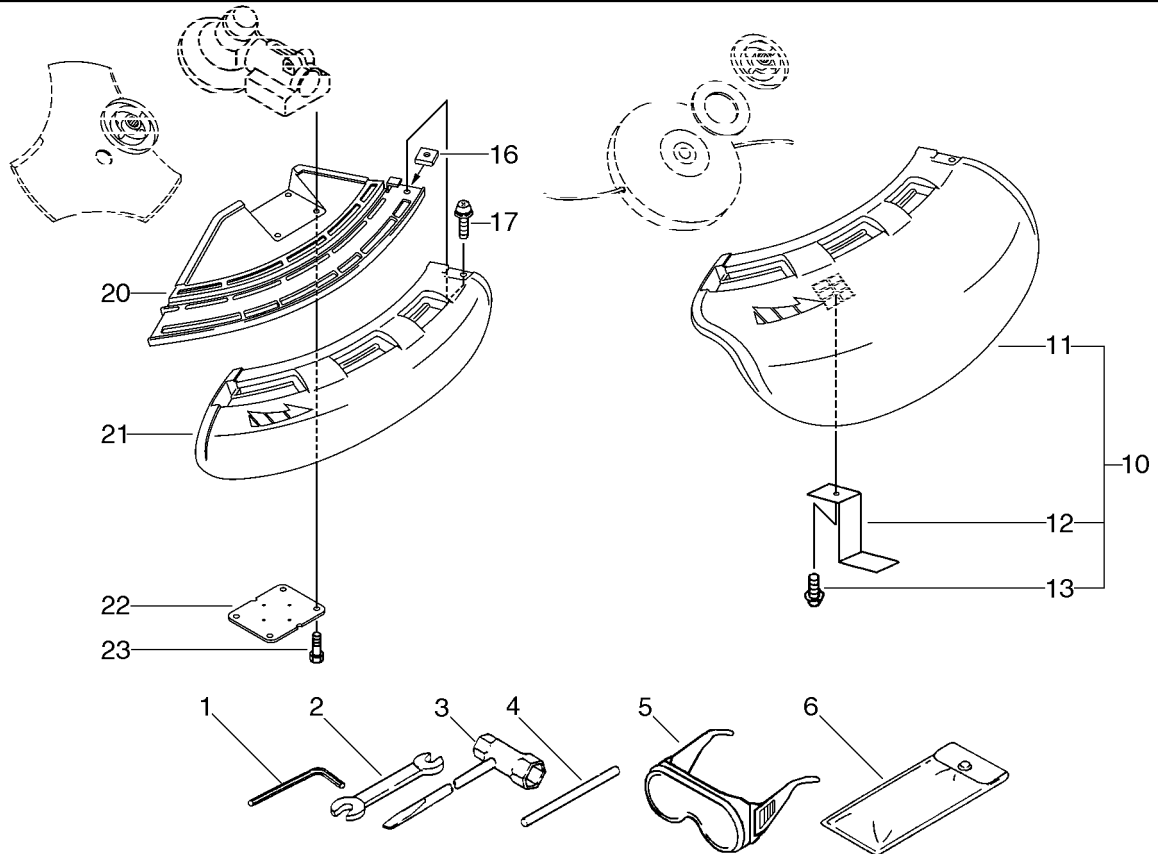

Bild	Artikelnummer	Anzahl	Beschreibung	Anmerkung
1	610400-56830	1	HOUSING ASY, GEAR	Sus. by 610400-56831
1	610400-56831	1	HOUSING ASY, GEAR	
2	+ 610320-52130	1	NUT 10	
3	+ 699229-56830	1	PLATE, COVER	
4	+ 610314-52130	1	PLATE, ADAPTER (L)	
5	+ 900720-00012	1	O-RING 12	
6	+ 610313-52930	1	PLATE, ADAPTER (U)	Sus. by C535-000000
6	+ C535-000000	1	FIXTURE, BRADE	
11	++ 610352-56830	1	PLATE, CUP	
14	++ C535-000010	1	FIXTURE, BRADE	
7	+ 900702-00032	1	CIRCLIP 32	
8	+ 610444-56830	1	WASHER	
9	+ 900812-06201	1	BEARING, BALL 6201	
10	+ 610310-56830	1	SHAFT, P.T.O.	
12	+ 610300-40830	1	GEAR SET	
13	+ 900810-00626	1	BEARING, BALL 626	
15	+ 610473-52130	1	SPRING, TORSION	Can be used on the 610313-52930 only/SRM-2015
15	+ 610473-52131	1	SPRING, TORSION	Can be used on the C535-000000 only/SRM-2015
15	+ 610473-52131	1	SPRING, TORSION	SRM-2015SI
16	+ 900603-50008	1	WASHER	
17	+ 610434-50030	1	BOLT 8* 6	Sus. by 610434-50031
17	+ 610434-50031	1	BOLT 8* 8	
18	+ 900242-05010	1	SCREW 5*10	
19	+ 900162-06025	1	BOLT, H.S. 6*25	
20	+ 900855-06900	1	BEARING, BALL 6900	
21	+ 900858-06900	1	BEARING, BALL 6900Z	
22	+ 900702-00022	1	CIRCLIP 22	
23	+ 900706-00010	1	CIRCLIP 10	
30	X405-000010	1	SAW, BUSH CUTTER	
34	898523-47130	1	SCABBARD, BLADE	
31	696001-48030	1	BLADE, 8-CUTTER	OPTION
33	898503-08030	1	COVER SET, CUTTER	OPTION

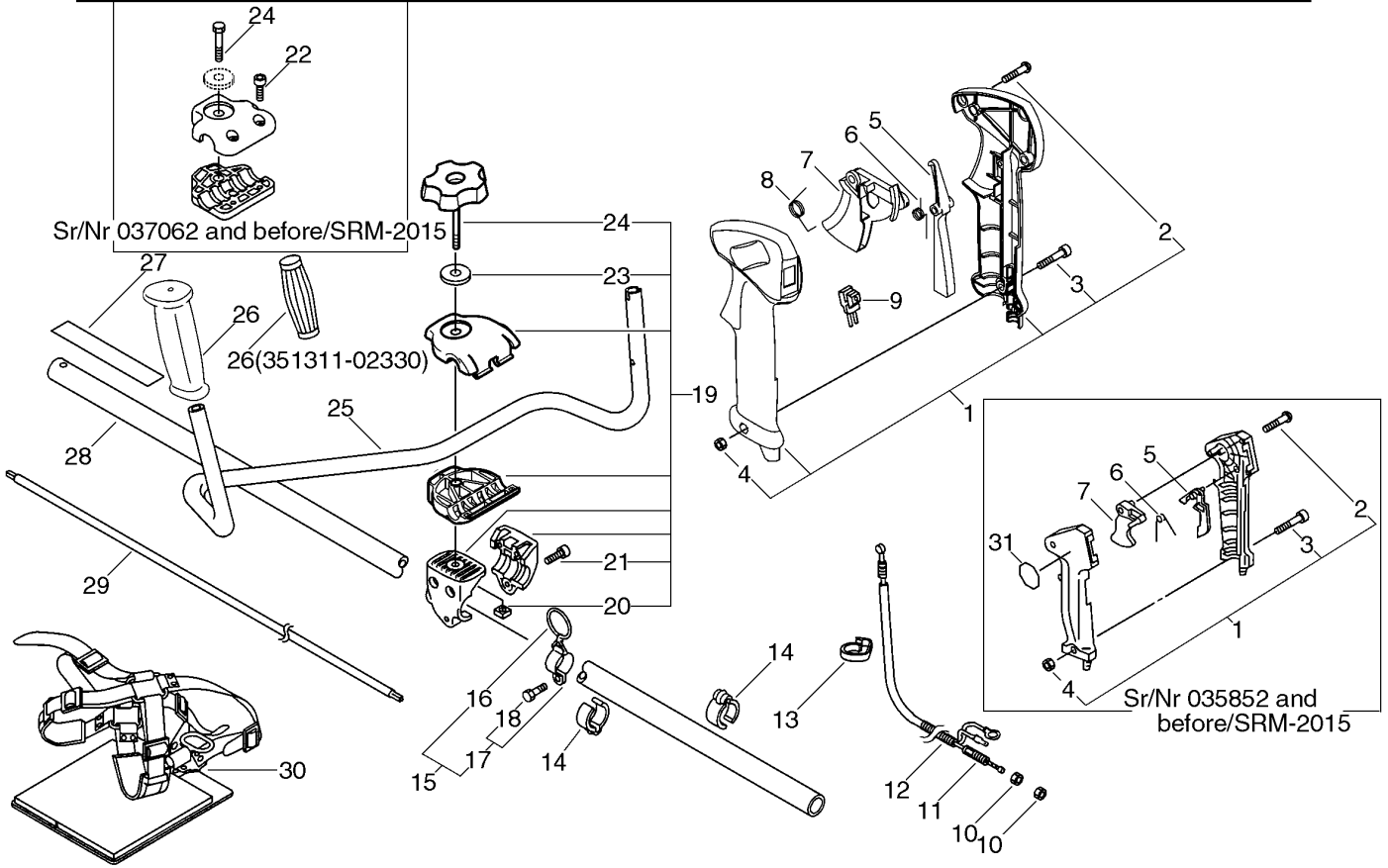

Bild	Artikelnummer	Anzahl	Beschreibung	Anmerkung	Bild	Artikelnummer	Anzahl	Beschreibung	Anmerkung
1	890177-46730	1	LABEL, CAUTION	Sus. by X505-000140	17	178003-52130	1	BRACKET SET, THROTTLE	
1	890617-63630	1	LABEL, CAUTION	Sus. by X505-000140	18 +	900242-05035	1	SCREW 5*35	
1	X505-000140	1	LABEL, CAUTION		19 +	900242-05025	1	SCREW 5*25	
2	351201-54130	1	HANDLE ASY, LOOP		24 +	900500-00005	2	NUT 5	
3 +	900242-05035	4	SCREW 5*35		20	178012-52630	1	LOCKOUT, THROTTLE	
4 +	900500-00005	4	NUT 5		21	178010-52130	1	CONTROL, THROTTLE	
5	610281-54130	1	COLLER		22	178043-42230	1	SPRING, THR. RETURN	
6 +	900253-04025	2	SCREW 4*25		23	163400-49230	1	SWITCH, IGNITION	
7	178127-54530	1	TUBE 7*130		25	178090-52630	1	LOCKOUT, T. CONTROL	
8	178001-51030	1	WIRE, THROTTLE		26	178013-52630	1	SPRING, THR. LOCK	
9	900502-00006	2	NUT 6 (3N)		27	351213-52130	1	GRIP, FRONT HANDLE	
10	610018-27830	1	SHAFT, DRIVE		28	610272-52130	1	BAND	
11	890157-39130	1	LABEL, SWITCH		24 +	900500-00005	1	NUT 5	
12	301207-08930	1	HOOK		29 +	900242-05028	1	SCREW 5*28	
13	900100-05018	1	BOLT 5*18		30	610206-28230	1	HOUSING ASY D.SFT.	
14	699012-03330	1	SPACER		31	301000-55230	1	HARNESS ASY	
15	301200-29430	1	BAND ASY		32 +	301305-24330	1	LINK	
16 +	900242-05014	1	SCREW 5*14						

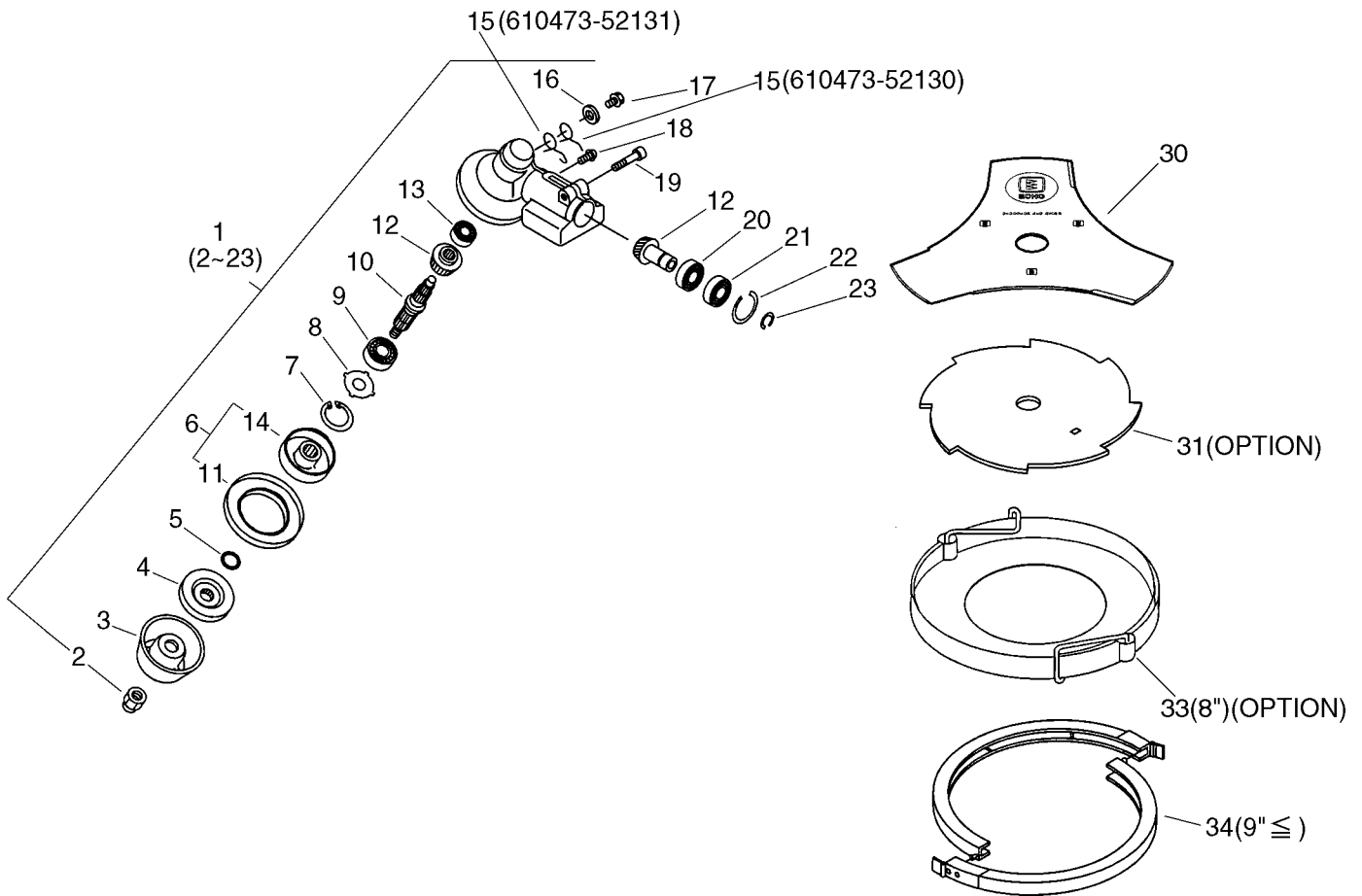

Bild	Artikelnummer	Anzahl	Beschreibung	Anmerkung
	125200-52430	1	CARBURETOR ASY	Sus. by 125200-52431
	125200-52431	1	CARBURETOR ASY	
1	+ 125344-52130	2	SCREW	
2	+ 125342-13210	1	COVER, DIAPHRAGM	
3	+ 125341-49030	1	DIAPHRAGM	
4	+ 125340-51030	1	GASKET, DIAPHRAGM	
5	+ 125339-42030	1	SCREW	
6	+ 125338-13930	1	PIN, METERING ARM	
7	+ 125323-42030	1	LEVER, METERING	
8	+ 125322-42030	1	SPRING, COIL	
9	+ 125337-06960	1	VALVE, INLET NEEDLE	
10	+ 125327-15130	1	CLIP	
11	+ 125376-49030	1	NOZZLE, CHECK VALVE	
12	+ 125326-42030	1	STRAINER	
13	+ 125312-12820	1	DIAPHRAGM, FUEL PUMP	
14	+ 125325-13310	1	GASKET, PUMP	
15	+ 125324-11610	1	COVER, PUMP	Sus. by P005-000590
15	+ 125383-13310	1	BASE, PRIMER	Sus. by P005-000590
15	+ P005-000590	1	BASE, ASY PRIMER	
16	+ 125381-08660	1	PUMP, PRIMING	
17	+ 125363-11610	1	RING	
18	+ 125310-11610	2	SCREW	
19	+ 125334-13930	1	SCREW, IDLE ADJUST	Sr/Nr 012002 and before /SRM-2015
19	+ 125334-06960	1	SCREW, IDLE ADJUST	Sr/Nr 012003 and after /SRM-2015
19	+ 125334-06960	1	SCREW, IDLE ADJUST	SRM-2015SI
20	+ 125378-13930	1	PIECE, FRICTION	Sr/Nr 012002 and before /SRM-2015
20	+ 125333-06960	1	SPRIG, ADJUST SCREW	Sr/Nr 012003 and after /SRM-2015
20	+ 125333-06960	1	SPRIG, ADJUST SCREW	SRM-2015SI
21	+ 125313-42030	1	SPRING, THRT. RETURN	
22	+ 125317-49030	1	SHAFT, THROTTLE	Sus. by P005-000390
22	+ P005-000390	1	SHAFT, THROTTLE	
23	+ 125372-42030	1	SWIVEL	
24	+ 125327-13930	1	CLIP	
25	+ 125320-52430	1	NEEDLE, HIGH SPEED	
26	+ 125318-52430	1	NEEDLE, IDLE	
27	+ 125314-13930	1	SCREW	
28	+ 125316-49030	1	VALVE, THROTTLE	
29	+ 125345-15130	1	PLUG, WELCH	

Dichtsatz

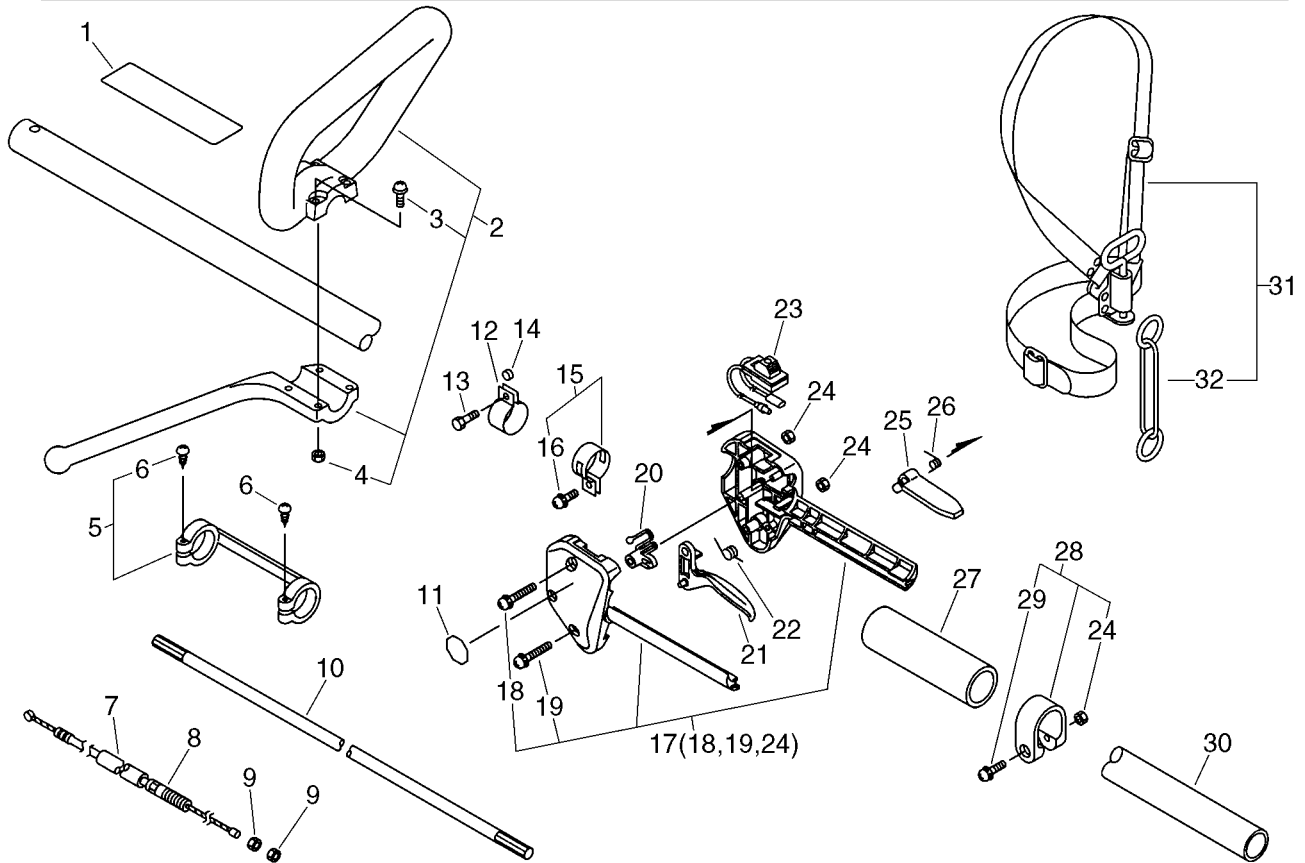
Bild	Artikelnummer	Anzahl	Beschreibung
	125303-13310	1	DIAPHRAGM/GASKET KIT
10-3	+ 125341-49030	1	DIAPHRAGM
10-4	+ 125340-51030	1	GASKET, DIAPHRAGM
10-11	+ 125312-12820	1	DIAPHRAGM, FUEL PUMP
10-14	+ 125325-13310	1	GASKET, PUMP
	125300-13310	1	REBUILD KIT
10-3	+ 125341-49030	1	DIAPHRAGM
10-4	+ 125340-51030	1	GASKET, DIAPHRAGM
10-6	+ 125338-13930	1	PIN, METERING ARM
10-7	+ 125323-42030	1	LEVER, METERING
10-8	+ 125322-42030	1	SPRING, COIL
10-9	+ 125337-06960	1	VALVE, INLET NEEDLE
10-11	+ 125326-42030	1	STRAINER
10-11	+ 125312-12820	1	DIAPHRAGM, FUEL PUMP
10-14	+ 125325-13310	1	GASKET, PUMP
10-2	+ 125345-15130	1	PLUG, WELCH

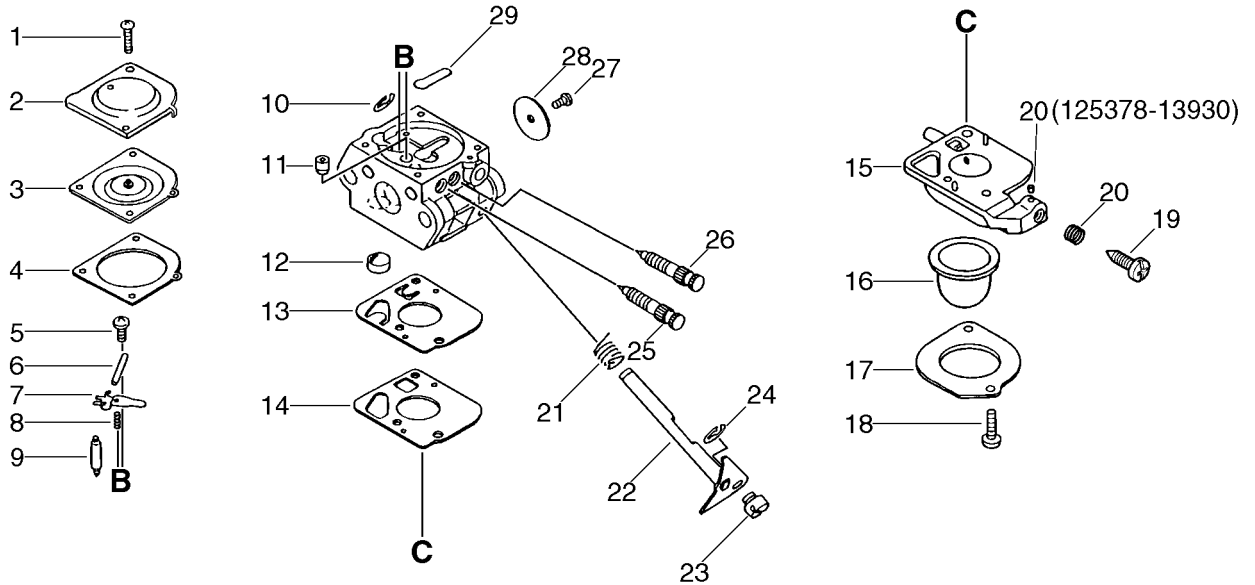
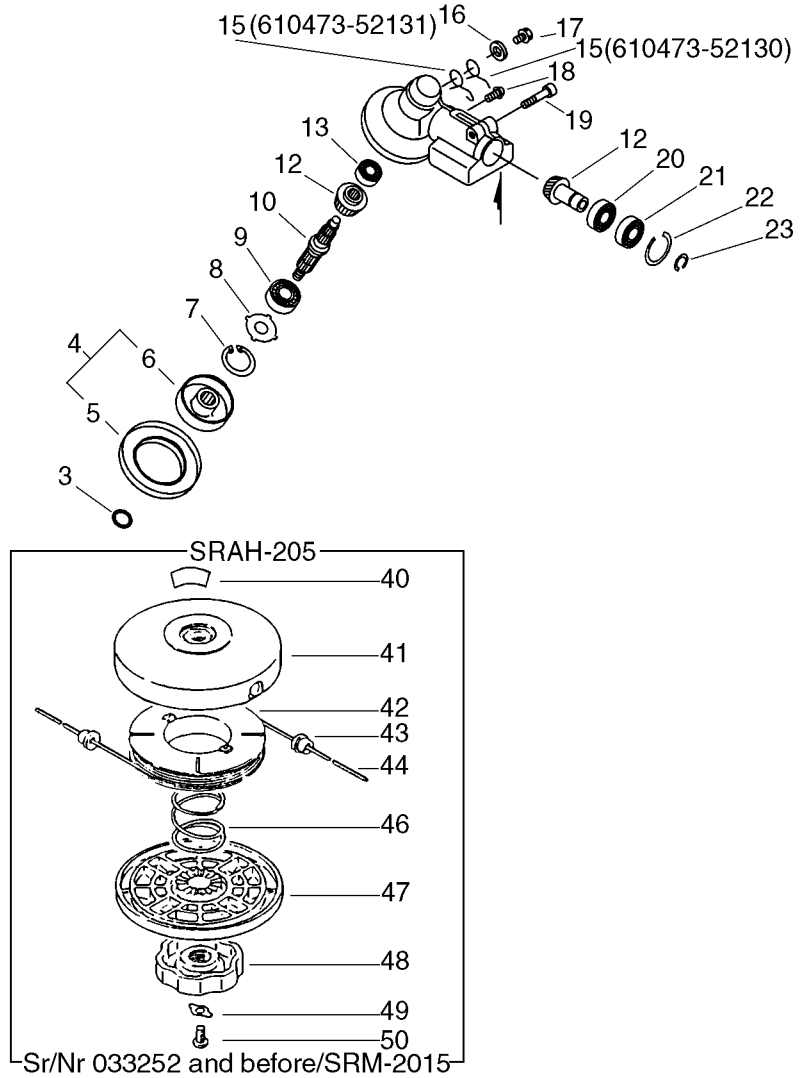
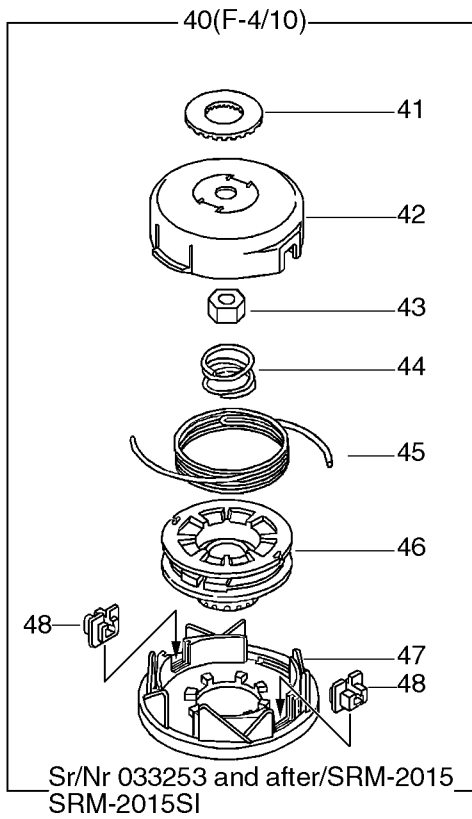

Bild	Artikelnummer	Anzahl	Beschreibung	Anmerkung
3	900720-00012	1	O-RING 12	
4	610313-52930	1	PLATE, ADAPTER (U)	Sus. by C535-000000
4	C535-000000	1	FIXTURE, BRADE	
5	+ 610352-56830	1	PLATE, CUP	
6	+ C535-000010	1	FIXTURE, BRADE	
7	900702-00032	1	CIRCLIP 32	
8	610444-56830	1	WASHER	
9	900812-06201	1	BEARING, BALL 6201	
10	610310-56830	1	SHAFT, P.T.O.	
12	610300-40830	1	GEAR SET	
13	900810-00626	1	BEARING, BALL 626	
15	610473-52130	1	SPRING, TORSION	Can be used on the 610313-52930 only/SRM-2015
15	610473-52131	1	SPRING, TORSION	Can be used on the C535-000000 only/SRM-2015
15	610473-52131	1	SPRING, TORSION	SRM-2015SI
16	900603-50008	1	WASHER	
17	610434-50030	1	BOLT 8* 6	Sus. by 610434-50031
17	610434-50031	1	BOLT 8* 8	
18	900242-05010	1	SCREW 5*10	
19	900162-06025	1	BOLT, H.S. 6*25	
20	900855-06900	1	BEARING, BALL 6900	
21	900858-06900	1	BEARING, BALL 6900Z	
22	900702-00022	1	CIRCLIP 22	
23	900706-00010	1	CIRCLIP 10	
40	890617-46730	1	LABEL, CAUTION	Sr/Nr 033252 and before/SRM-2015
41	696210-56930	1	DRUM, REEL	Sr/Nr 033252 and before/SRM-2015
42	696214-06830	1	REEL, CORD	Sr/Nr 033252 and before/SRM-2015
43	696212-06032	2	EYELET	Sr/Nr 033252 and before/SRM-2015
44	696215-22830	2	CORD, NYLON(2.4*2.5)	Sr/Nr 033252 and before/SRM-2015
46	696216-06030	1	SPRING	Sr/Nr 033252 and before/SRM-2015
47	696206-28232	1	COVER, DRUM (BL)	Sr/Nr 033252 and before/SRM-2015
48	696219-28231	1	NUT (BL)	Sr/Nr 033252 and before/SRM-2015
49	696220-06030	1	STOPPER, NUT	Sr/Nr 033252 and before/SRM-2015
50	900220-06010	1	SCREW 6*10	Sr/Nr 033252 and before/SRM-2015
40	X047-000050	1	CUTTER,ASM LINE	Sus. by X047-000151
40	X047-000150	1	CUTTER,ASM LINE	Sus. by X047-000151
40	X047-000151	1	CUTTER,ASM LINE	Sr/Nr 033253 and after/SRM-2015
40	X047-000151	1	CUTTER,ASM LINE	SRM-2015SI
41	+ V332-000000	1	WASHER,CIRCULAR 24	Sr/Nr 033253 and after/SRM-2015
41	+ V332-000000	1	WASHER,CIRCULAR 24	SRM-2015SI
42	+ X470-000020	1	DRUM,REEL	Sus. by P022-003310
42	+ P022-002890	1	HOUSING	Sus. by P022-003310
42	+ P022-003310	1	HOUSING	Sr/Nr 033253 and after/SRM-2015
42	+ P022-003310	1	HOUSING	SRM-2015SI
43	+ P022-001220	1	NUT	Sr/Nr 033253 and after/SRM-2015
43	+ P022-001220	1	NUT	SRM-2015SI
44	+ P022-001250	1	SPRING	Sr/Nr 033253 and after/SRM-2015
44	+ P022-001250	1	SPRING	SRM-2015SI
45	+ P022-001230	1	NYLON CODE	Sr/Nr 033253 and after/SRM-2015
45	+ P022-001230	1	NYLON CODE	SRM-2015SI
46	+ P022-001260	1	BOBBIN	Sr/Nr 033253 and after/SRM-2015
46	+ P022-001260	1	BOBBIN	SRM-2015SI
47	+ P022-001240	1	COVER	Sus. by P022-003330
47	+ P022-002860	1	COVER	Sus. by P022-003330
47	+ P022-003330	1	COVER	Sr/Nr 033253 and after/SRM-2015
47	+ P022-003330	1	COVER	SRM-2015SI
48	+ P022-000710	2	EYELET	Sr/Nr 033253 and after/SRM-2015
48	+ P022-000710	2	EYELET	SRM-2015SI

ECHO®

Motorgeräte

die geh'n ran