

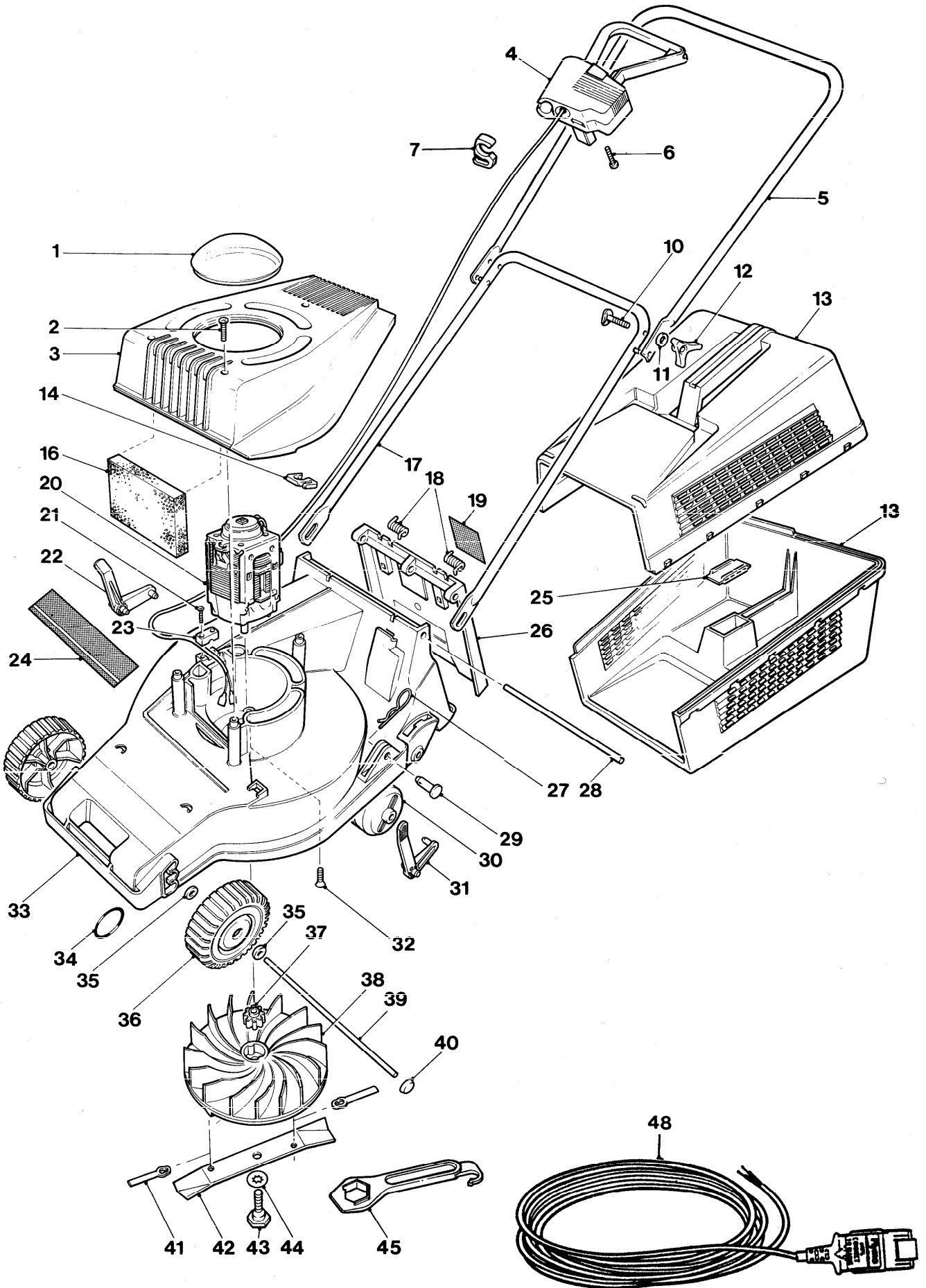

CHEVRON RE 300T TWIN 9643007
RE30-4





CHEVRON RE 300T TWIN 9643007

RE30-4

KEY No.	PART No	DESCRIPTION	QUANTITY	COMMENTS APPLICATION	KEY No.	PART No	DESCRIPTION	QUANTITY	COMMENTS APPLICATION
1	5126120-03/8	LENS	1		36	5126674-00/0	WHEEL	2	
2	5146824-00/7	SCREW	3		37	5126764-00/9	INSERT-PLASTIC	1	
3	5116939-01/7	COWLING ASSY	1		38	5137485-00/8	FAN ASSY/IMPELLER	1	
4	5126891-01/8	SWITCHBOX ASSY	1	GB.EI.	39	5137483-00/3	AXLE	1	
	5126901-01/5	SWITCHBOX (EUROPE)	1	F.B.N.L.A.	40	5148175-00/2	AXLE CAP	2	
	5126901-02/3	SWITCHBOX (EUROPE)	1	N.DK.	41	5148257-02/4	CUTTER PLASTIC LONG LIFE	2	
5	5126816-02/3	HANDLE/LABEL ASSY	1		42	5126676-00/5	BLADE 30cm	1	
	5126242-03/0	HANDLE UPPER PLASTIC COATED	1		43	5137608-00/5	BLADE BOLT C/W PTFE WASHER	1	
6	5146672-00/0	SCREW GKN POLYMATE	2		44	5148259-00/4	WASHER ANTI-FRICTION PTFE	1	
7	5137750-00/5	CABLE CLIP SMALL	1		45	5126682-00/3	SPANNER/SCRAPER ABS	1	
10	5140607-00/2	BOLT HANDLE ¼ UNC x 45LG	2		48	5126890-01/0	CABLE EXTENSION	1	GB.EI.O/S.
11	5140266-00/7	WASHER	2						
12	5140690-00/8	KNOB WING WHITE	2						
13	5126686-00/4	GRASSBOX (HALF)	2						
14	5137750-00/5	CABLE CLIP LARGE	1						
16	5148603-00/2	FILTER	1						
17	5117082-00/7	HANDLE LOWER	1						
18	5136711-00/8	SPRING SAFETY FLAP	2						
19	5146467-00/5	LABEL WARNING ELECTRIC	1	GB.EI.					
	5146516-00/9	LABEL WARNING ELECTRIC	1	A.F.NL.					
	5137659-00/8	LABEL WARNING ELECTRIC	1	B.N.L.A.					
	5136712-01/4	LABEL WARNING ELECTRIC	1	DK.N.					
20	5126825-01/6	MOTOR 240 VOLT BRAKED	1						
	5126677-02/9	MOTOR 220 VOLT	1						
21	5146824-00/7	SCREW	2						
22	5126675-01/5	LEVER H.O.C. R/H	1						
23	5136692-01/8	CABLE CLAMP	1						
24	5127047-00/8	LABEL FLYMO 300 TWIN	1						
	5126808-00/4	LABEL FLYMO RE30	1						
25	5137452-00/8	COVER PLATE	2						
26	5116875-00/5	FLAP	1						
27	5140423-00/4	PIN RETAINING	2						
28	5137484-00/1	HINGE PIN	1						
29	5140092-00/7	PIVOT PIN	2						
30	5137602-00/8	ROLLER ASSY	1						
31	5126675-00/7	LEVER H.O.C. L/H	1						
32	5148122-01/2	SCREW PLASTITE 10 x 19mm LNG	4						
33	5106317-01/8	CHASSIS	1						
34	5148178-00/6	O RING	2						
35	5140281-04/8	WASHER	4						

A Österreich, AUS Australia, B Belgique/Belgie, CND Canada, CH Schweiz/Suisse, D Deutschland, DK Danmark, E Espania, EI Eire, F France, GB Great Britain, I Italia, N Norge, NL Nederland, NZ New Zealand, O/S Overseas, P Portugal, S Sverige, SF Suomi, USA U.S.A., ZA South Africa

WHERE NO APPLICATION DETAILS ARE SHOWN, PART APPLIES TO ALL COUNTRIES

9643007-25 GB