

# **ILLUSTRATED PARTS LIST**

**MFG. ID NO. 96011018303**

**CUSTOMER CATALOG NO. FL12597**

**PRODUCT NO. 960 11 01-83**

# REPAIR PARTS

TRACTOR - - MODEL NUMBER FL12597 (96011018303), PRODUCT NO. 960 11 01-83  
DECALS

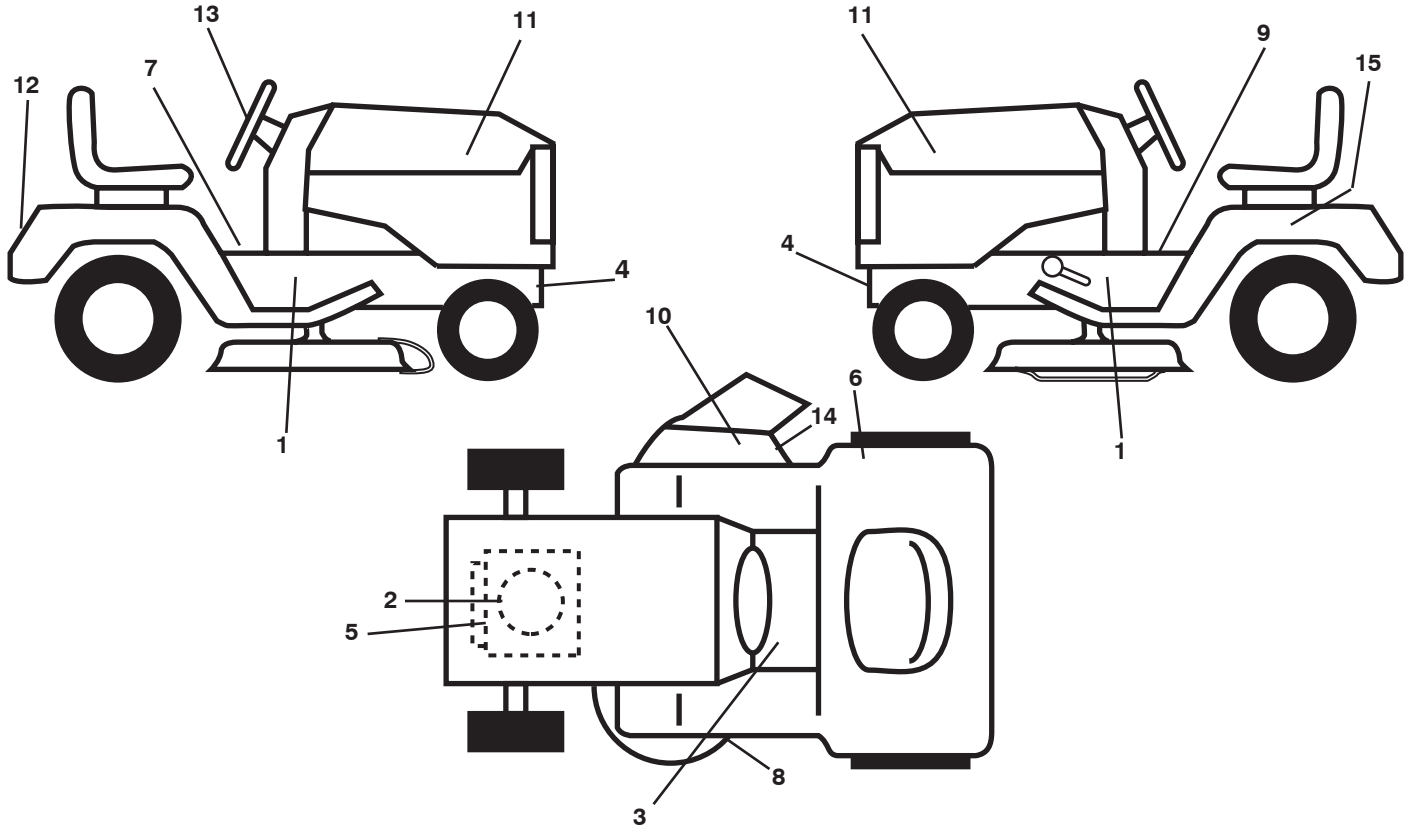

KEY NO.	PART NO.	DESCRIPTION
1	532 18 56-51	Decal, Chassis
2	532 19 68-41	Decal, Warning Eng. Sym.
3	532 15 97-37	Decal, Brake/Clutch
4	532 15 97-36	Decal, Hot Muffler
5	532 40 88-13	Decal, Eng. HP
6	532 18 04-32	Decal, DB/CE
7	532 40 03-89	Decal, Warning Sym. CE
8	532 19 43-02	Decal, V-Belt Sch.
9	532 14 08-37	Decal, Saddle Brake Parking
10	532 18 21-66	Decal, Cut Finger

KEY NO.	PART NO.	DESCRIPTION
11	532 19 59-52	Decal, Hood
12	532 40 19-88	Decal, Fender
13	532 40 19-87	Decal, Wheel Strg.
14	532 19 63-57	Decal, Defl. Warning
15	532 14 50-05	Decal, Caution, Battery
--	532 16 25-98	Decal, Drawbar
--	532 13 83-11	Decal, Handle Lft Height Adj.
--	532 40 09-01	Manual, Operator's, Euro
--	532 40 09-02	Manual, Operator's, Scan

## WHEELS & TIRES

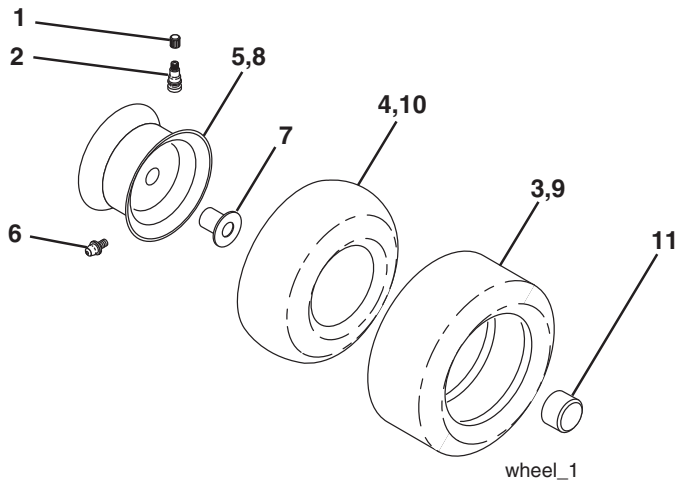

KEY NO.	PART NO.	DESCRIPTION
1	532 05 91-92	Cap, Tire valve
2	532 06 51-39	Stem, Valve
3	532 12 41-57	Tire, Front
4	532 05 99-04	Tube, Front (Service item only)
5	532 18 33-37	Rim assembly, 6" front
6	532 18 33-38	Fitting, Grease (Front wheel only)
7	532 12 49-59	Bearing, Flange (Front wheel only)
8	532 12 51-22	Rim assembly, 8" rear
9	532 12 39-69	Tire, Rear
10	532 12 49-26	Tube, Rear (Service item only)
11	532 17 50-39	Cap, Hub Axle
--	532 14 43-34	Sealant, Tire (10 oz. Tube)

**NOTE:** All component dimensions given in U.S. inches  
1 inch = 25.4 mm.

# TRACTOR - - MODEL NUMBER FL12597 (96011018303), PRODUCT NO. 960 11 01-83 SCHEMATIC

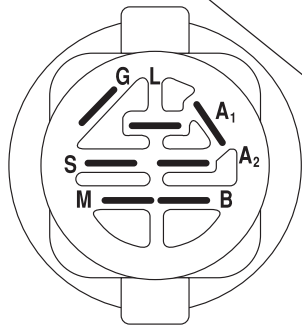
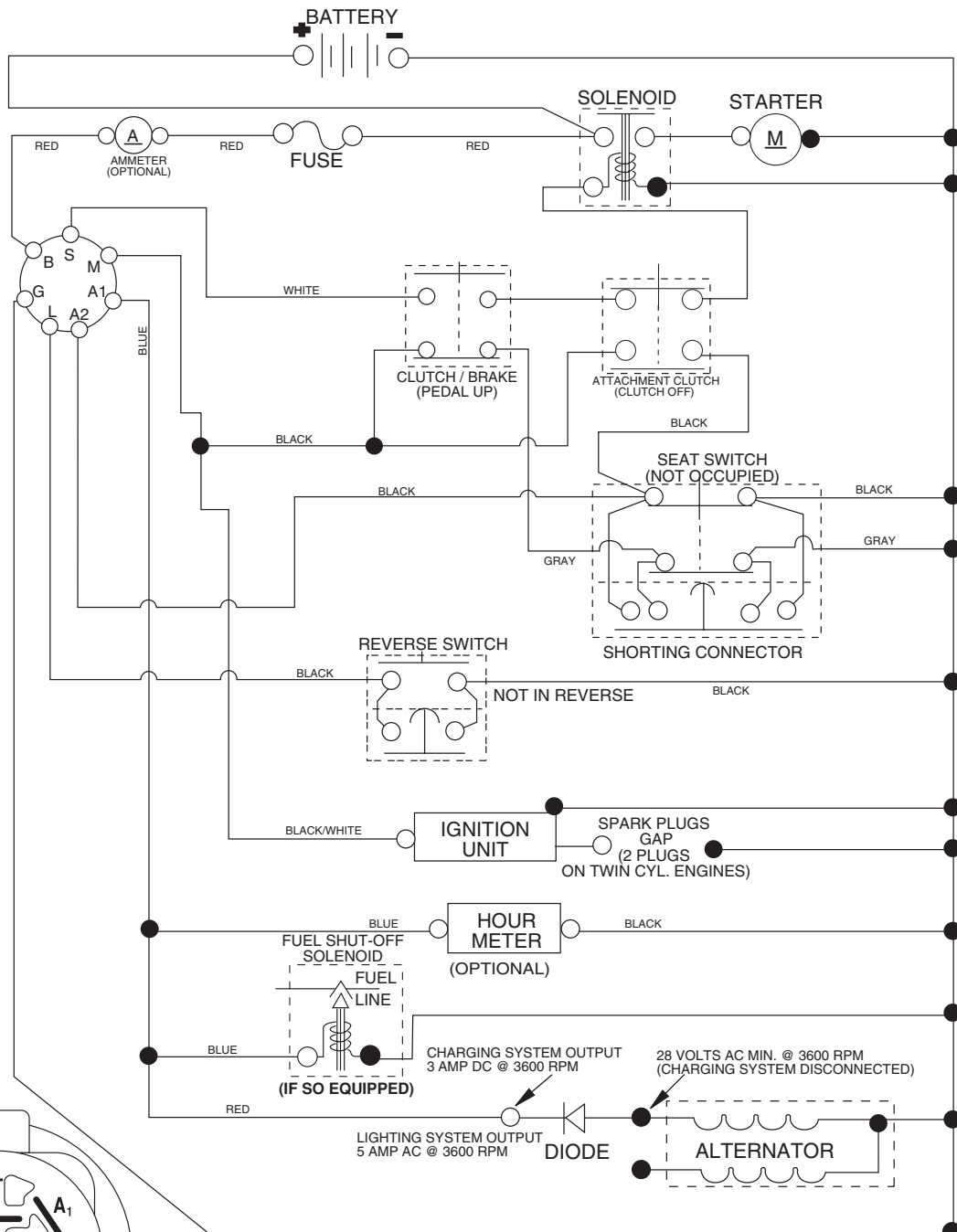

**IGNITION SWITCH**

POSITION	CIRCUIT "MAKE"
OFF	M+G+A1
RUN/OVERRIDE	B+A1
RUN	B+A1 L+A2
START	B + S + A1

03049

## NOTE

YOUR TRACTOR IS EQUIPPED WITH A SPECIAL ALTERNATOR SYSTEM. THE LIGHTS ARE NOT CONNECTED TO THE BATTERY, BUT HAVE THEIR OWN ELECTRICAL SOURCE. BECAUSE OF THIS, THE BRIGHTNESS OF THE LIGHTS WILL CHANGE WITH ENGINE SPEED. AT IDLE THE LIGHTS WILL DIM. AS THE ENGINE IS SPEEDED UP, THE LIGHTS WILL BECOME THEIR BRIGHTEST.

●  
NON-REMOVABLE CONNECTIONS

○  
REMOVABLE CONNECTIONS

## WIRING INSULATED CLIPS

**NOTE:** IF WIRING INSULATED CLIPS WERE REMOVED FOR SERVICING OF UNIT, THEY SHOULD BE REPLACED TO PROPERLY SECURE YOUR WIRING.

# REPAIR PARTS

TRACTOR - - MODEL NUMBER FL12597 (96011018303), PRODUCT NO. 960 11 01-83

## ELECTRICAL

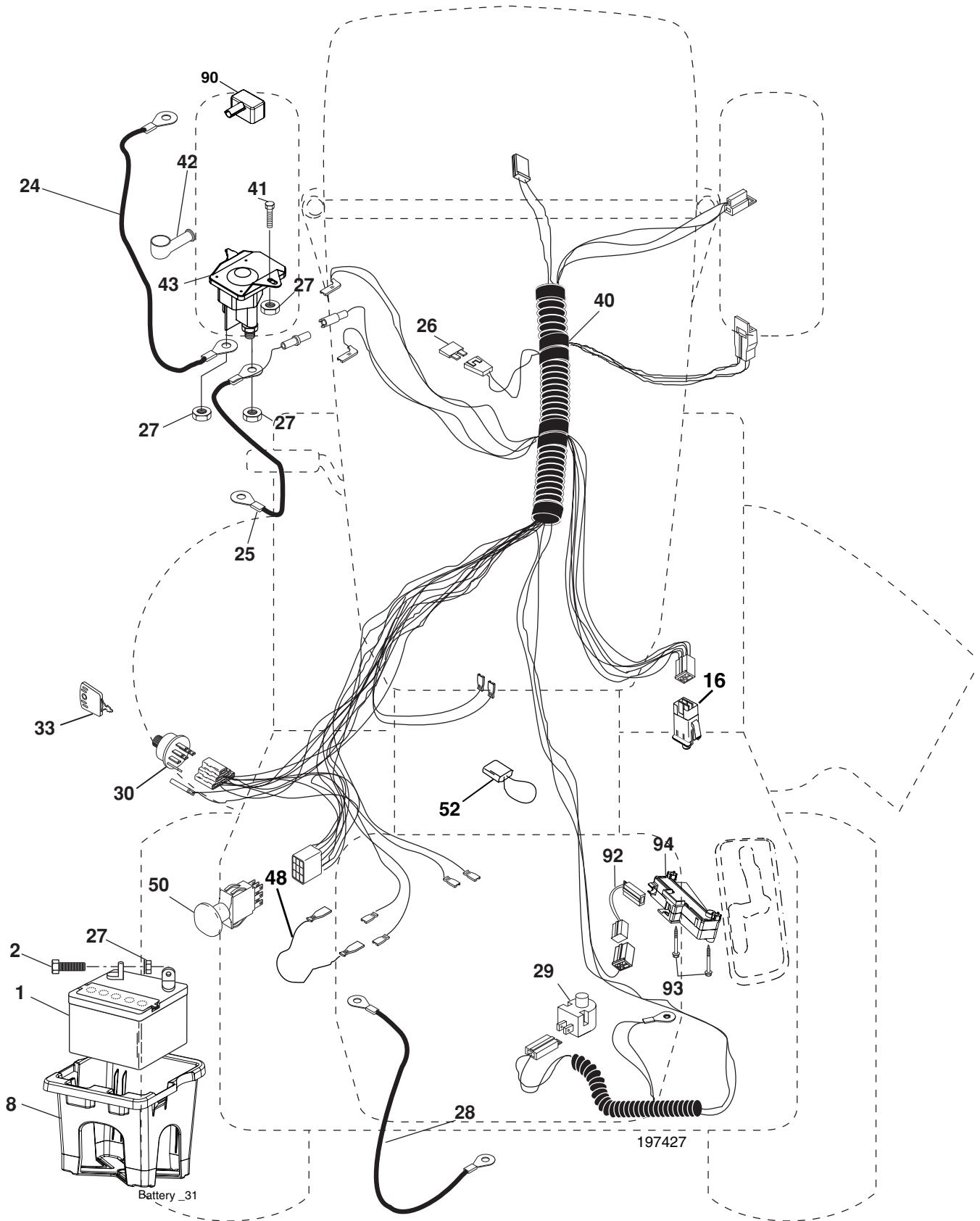

# REPAIR PARTS

TRACTOR - - MODEL NUMBER FL12597 (96011018303), PRODUCT NO. 960 11 01-83  
ELECTRICAL

KEY NO.	PART NO.	DESCRIPTION
1	532 16 34-65	Battery 12 Volt 25 Amp
2	874 76 04-12	Bolt Hex Hd 1/4-20 Unc x 3/4
8	532 17 66-89	Battery Box
16	532 17 61-38	Switch Interlock Push-In
24	532 12 47-80	Cable Battery 6 Ga. 11"red
25	532 14 61-47	Cable Battery
26	532 17 51-58	Fuse
27	873 51 04-00	Nut Keps Hex 1/4-20 unc
28	532 12 47-73	Cable Ground 6 Ga. 12"black
29	532 19 27-49	Switch Seat
30	532 19 33-50	Switch Ign
33	532 14 04-01	Key Ign
40	532 19 74-27	Harness Ign
41	871 11 04-08	Bolt Blk Fin Hex 1/4-20
42	532 13 15-63	Cover Terminal Red
43	532 19 25-07	Solenoid
48	532 14 08-44	Adapter Ammeter
52	532 14 19-40	Protection Wire Loop
90	532 18 04-49	Cover Terminal Battery
92	532 19 66-15	Harness Pigtail ROS
93	532 19 25-40	Screw Plastite 10-14 x 2.0
94	532 19 18-34	Module Reverse ROS

**NOTE:** All component dimensions given in U.S.  
inches 1 inch = 25.4 mm.

# REPAIR PARTS

TRACTOR - - MODEL NUMBER FL12597 (96011018303), PRODUCT NO. 960 11 01-83  
CHASSIS AND ENCLOSURES

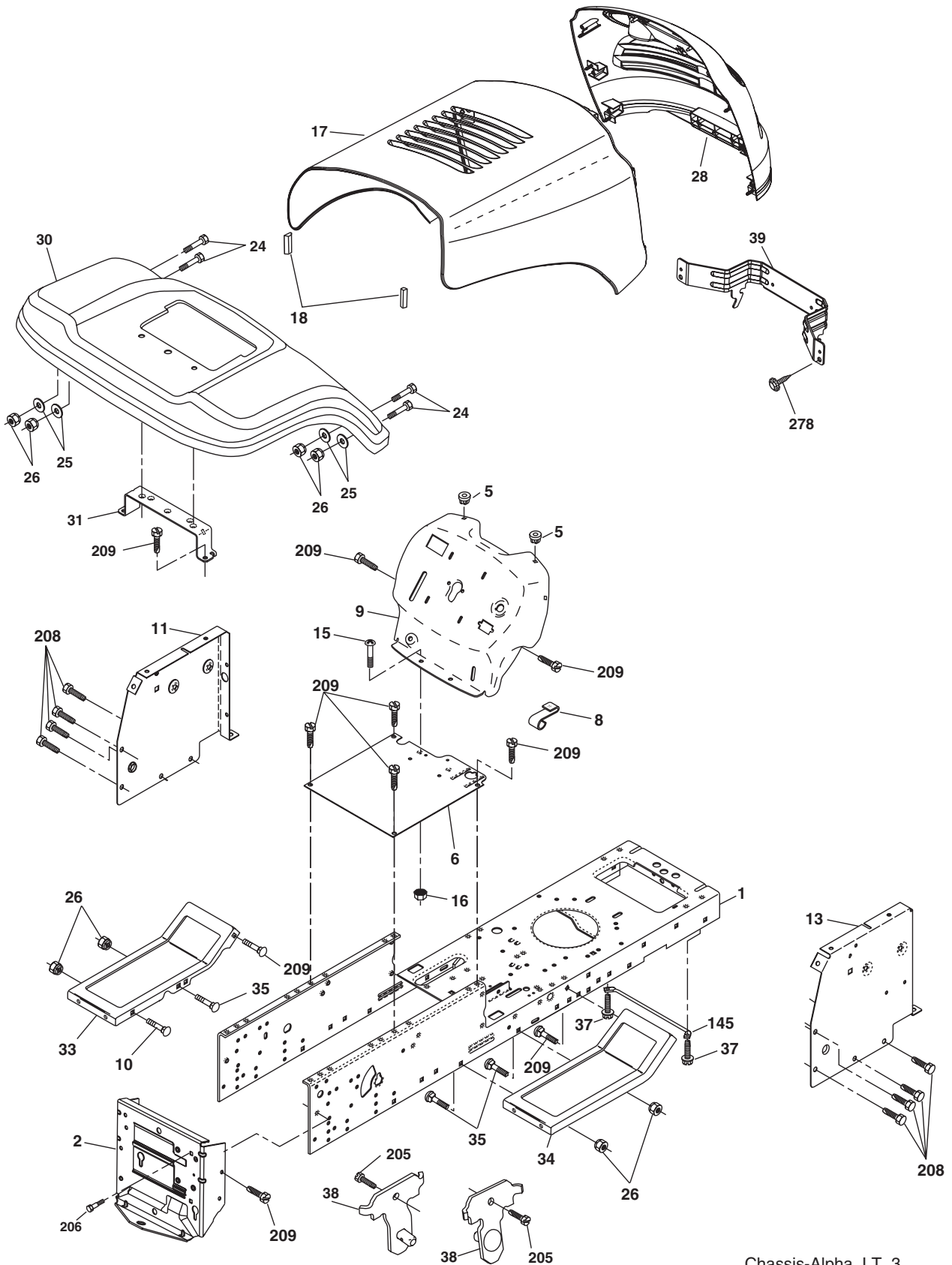

Chassis-Alpha\_LT\_3

# REPAIR PARTS

TRACTOR - - MODEL NUMBER FL12597 (96011018303), PRODUCT NO. 960 11 01-83  
CHASSIS AND ENCLOSURES

KEY NO.	PART NO.	DESCRIPTION
1	532 17 46-20	Chassis
2	532 17 65-54	Drawbar
5	532 15 52-72	Bumper, Hood/Dash
6	532 18 44-19	Saddle
8	532 15 51-38	Clip Retainer Slide-On
9	532 19 46-88	Dash
10	872 14 06-08	Bolt, Carriage 3/8-16 x 1
11	532 17 49-96	Panel Dash LH
13	532 18 17-19	Panel Slkscr Dash RH
15	874 18 05-12	Screw Mach TRHD 5/16-18 unc x 3/4
16	873 51 05-00	Nut Keps 5/16-18 Unc
17	532 19 65-90	Hood
18	532 18 49-21	Bumper Hood
24	874 78 06-16	Bolt Fin Hex 3/8-16 unc x 1 Gr. 5
25	819 13 13-12	Washer 13/32 x 13/16 x 12 Ga.
26	873 80 06-00	Nut Lock Hex w/Ins 3/8-16 unc
28	532 19 47-98	Grille
30	532 40 30-26	Fender
31	532 13 66-19	Bracket Fender Repl 109873x
33	532 18 64-57	Footrest Pnt LH
34	532 18 64-58	Footrest Pnt RH
35	872 11 06-06	Bolt Rdhd Sht Sqnk 3/8-16 x 3/4
37	817 49 05-08	Screw Thdrol 5/16-18 x 1/2 TYT
38	532 17 57-10	Bracket Asm. Pivot Mower Rear
39	532 18 75-68	Bracket Pivot
145	532 15 65-24	Rod Pivot Chassis/Hood
205	817 49 06-08	Screw Thdrol 3/8-16 x 1/2
206	532 17 01-65	Bolt Shoulder 5/16-18
208	817 67 06-08	Screw Thdrol 3/8-16 x 1/2
209	817 00 06-12	Screw Hex Wsh Thdrol 3/8-16
278	532 19 16-11	Screw 10 x 3/4 Single Lead-Hex
--	532 00 54-79	Plug Button Blk 359 Dia Choke
--	532 19 39-35	Plug Switch Light

**NOTE:** All component dimensions given in U.S. inches  
1 inch = 25.4 mm.

# REPAIR PARTS

TRACTOR - - MODEL NUMBER FL12597 (96011018303), PRODUCT NO. 960 11 01-83  
DRIVE

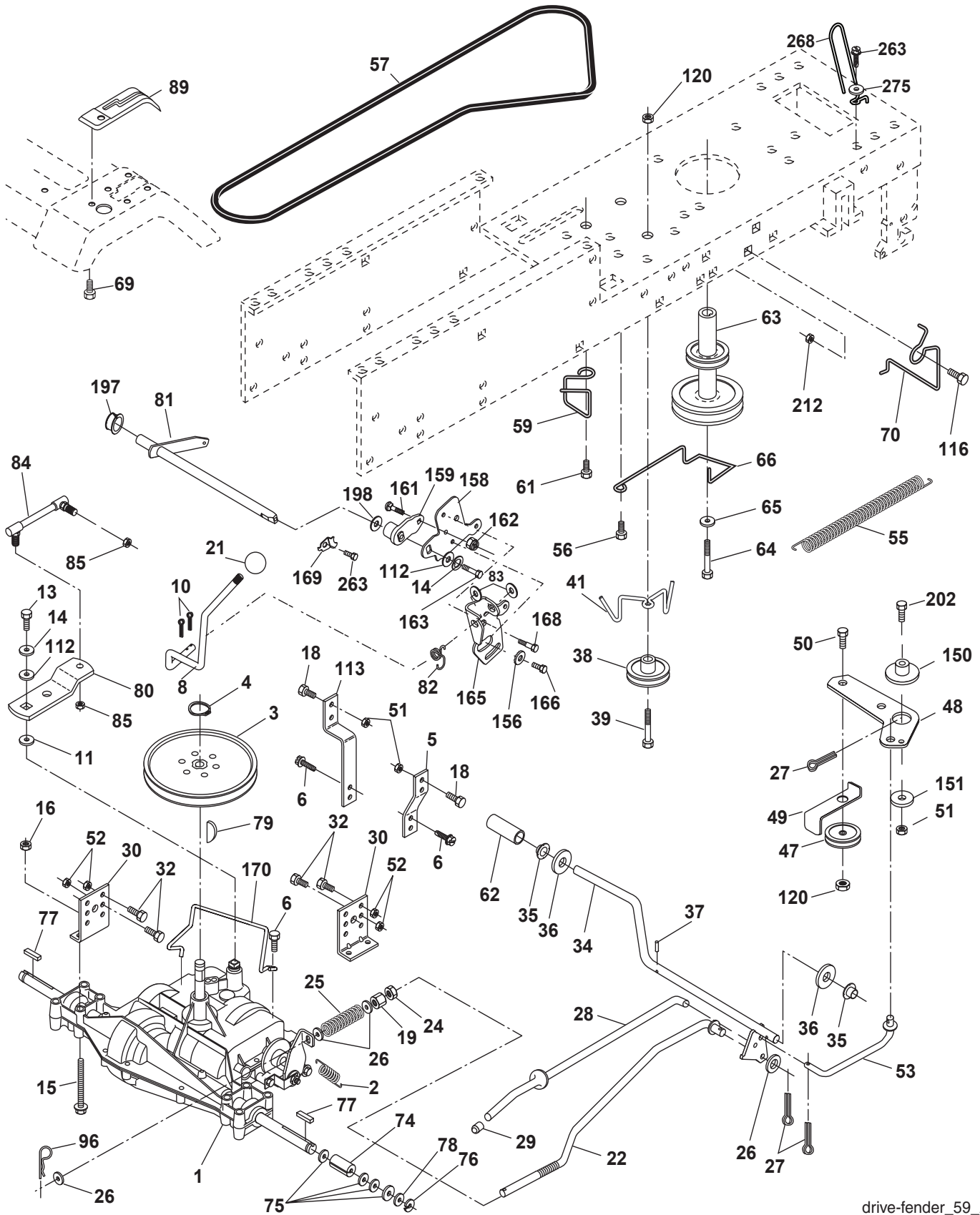

drive-fender\_59\_A

# REPAIR PARTS

TRACTOR - - MODEL NUMBER FL12597 (96011018303), PRODUCT NO. 960 11 01-83  
DRIVE

KEY NO.	PART NO.	DESCRIPTION	KEY NO.	PART NO.	DESCRIPTION
1	-----	Transaxle <b>Peerless 205-544C</b> Order parts from transaxle manufacturer	62	532 12 48-72	Cover Pedal Round
2	532 14 66-82	Spring Return Brake T/a Zinc	63	532 17 54-10	Engine Pulley
3	532 12 36-66	Pulley Transaxle 18" tires	64	532 17 39-37	Bolt Hex
4	812 00 00-28	Ring Retainer # 5100-62	65	810 04 07-00	Washer Lock Hvy Hlcl Spr 7/16
5	532 12 15-20	Strap Torque 30 Degrees	66	532 15 47-78	Keeper Belt Engine Foolproof
6	817 06 05-12	Screw Thdrol 5/16-18 x 3/4	69	532 14 24-32	Screw Hex 1/4-1/2 unc
8	532 19 27-06	Rod Shift Fender Adjust Lt	70	532 13 46-83	Guide Belt Mower Drive RH
10	876 02 04-16	Pin Cotter 1/8 x 1 Cad	74	<b>532 13 70-57</b>	Spacer Axle
11	532 10 57-01	Washer Plate Shf 388 Sq Hole	75	532 12 17-49	Washer 25/32 x 1 1/4 x 16 Ga.
13	874 55 04-12	Bolt 1/4-28 unF Gr. 8 W/Patch	76	812 00 00-01	E-ring #5133-75
14	810 04 04-00	Washer Lock Hvy Helical	77	532 12 35-83	Key Square 2 0 x 1845/ 1865
15	874 49 05-44	Bolt Hex 5/16-18 Gr. 5	78	532 12 17-48	Washer 25/32 x 1-5/8 x 16 Ga.
16	873 80 05-00	Nut Lock Hex w/Ins 5/16-18	79	532 12 50-96	Key Woodruff #9 3/16 x 3/4
18	874 78 06-16	Bolt, Fin Hex 3/8-16 unc x 1 Gr. 5	80	<b>532 13 14-86</b>	Arm Shift
19	873 80 06-00	Nut Lock 3/8-16 unc	81	532 16 55-94	Shaft Asm Cross 18"t
21	532 10 69-33	Knob	82	532 16 57-11	Spring Torsion T/a
22	532 13 08-04	Rod Brake Blk Zinc 26 840	83	819 17 12-16	Washer 17/32 x 3/4 x 16 Ga.
24	873 35 06-00	Nut Hex Jam 3/8-16 unc	84	<b>532 16 62-28</b>	Link Transaxle
25	532 10 68-88	Spring Rod Brake 2 00 Zinc	85	532 15 03-60	Nut Lock Center 1/4 - 28 FNTHD
26	819 13 13-16	Washer 13/32 x 13/16 x 16 Ga.	89	532 19 58-61	Console Shift STLT
27	876 02 04-12	Pin Cotter 1/8 x 3/4 Cad	96	532 12 47-88	Retainer Spring 1"
28	532 17 57-65	Rod Brake Parking LT/YT	112	819 09 12-10	Washer 9/32 x 3/4 x 10 Ga.
29	532 07 16-73	Cap Brake Parking Black	113	532 12 72-85	Strap Torque LT
30	532 17 49-73	Bracket Mtg Transaxle	116	872 14 06-08	Bolt Rdhd Sq Neck 3/8-16 x 1.0
32	874 76 05-12	Bolt Hex Hd 5/16-18 unc x 3/4	120	873 90 06-00	Nut Lock Flg. 3/8-16 unc
34	532 17 55-78	Shaft Asm Pedal Foot	150	532 17 54-56	Spacer
35	532 12 01-83	Bearing Nylon Blk 629 Id	151	819 13 32-10	Washer 13/32 x 2 x 10 Ga.
36	819 21 16-16	Washer 21/32 x 1 x 16 Ga.	156	532 16 60-02	Washer Srrted 5/16 ID x 1.125
37	532 12 49-63	Pin Roll 3/16 x 1"	158	532 16 55-89	Bracket Shift Mount
38	532 17 91-14	Pulley Idler Composite	159	532 18 39-00	Hub Shift
39	872 11 06-22	Bolt Fin Hex 3/8-16 unc x 2-3/4 Gr. 5	161	872 14 04-06	Bolt Rdhd Sqnk 1/4-20 x 3/4 Gr. 5
41	532 17 55-56	Keeper Belt Idler Flat	162	873 68 04-00	Nut Crownlock 1/4-20 unc
47	532 12 77-83	Pulley Idler V Groove Plastic	163	874 78 04-16	Bolt Hex Fin 1/4-20 unc x 1 Gr. 5
48	532 15 44-07	Bellcrank Clutch Grnd Driv	165	532 16 56-23	Bracket Pivot Lever
49	532 12 32-05	Retainer Belt Style Spring	166	817 49 05-10	Screw 5/16-18 x 5/8
50	872 11 06-12	Bolt 3/8-16 x 1-1/2 Gr. 5	168	532 16 54-92	Bolt Shoulder 5/16-18 x .561
51	873 68 06-00	Nut Crownlock 3/8-16 unc	169	532 16 55-81	Plate Fastening Lt
52	873 68 05-00	Nut Crownlock 5/16-18 unc	170	532 18 74-14	Keeper, Belt T/A
53	532 19 96-52	Link Clutch	197	532 16 96-13	Nyliner Snap-In
55	532 10 57-09	Spring Return Clutch 6 75	198	532 16 98-45	Washer Nyl
56	817 06 06-20	Screw 3/8-16 x 3/4	202	872 11 06-14	Bolt Carr. SH 3/8-16 x 1-3/4 Gr. 5
57	<b>532 13 82-55</b>	V-Belt Ground Drive 95 25	212	532 14 52-12	Nut, Hex Flange Lock
59	532 16 96-91	Keeper Belt Span Ctr	263	817 00 06-12	Screw 3/8-16 x 3/4
61	817 12 06-14	Screw 3/8-16 x .875	268	532 18 24-02	Guard Muffler
			275	819 13 16-14	Washer 13/32 x 1 x 14 Ga.

**NOTE:** All component dimensions given in U.S. inches  
1 inch = 25.4 mm.

# REPAIR PARTS

TRACTOR - - MODEL NUMBER FL12597 (96011018303), PRODUCT NO. 960 11 01-83  
STEERING

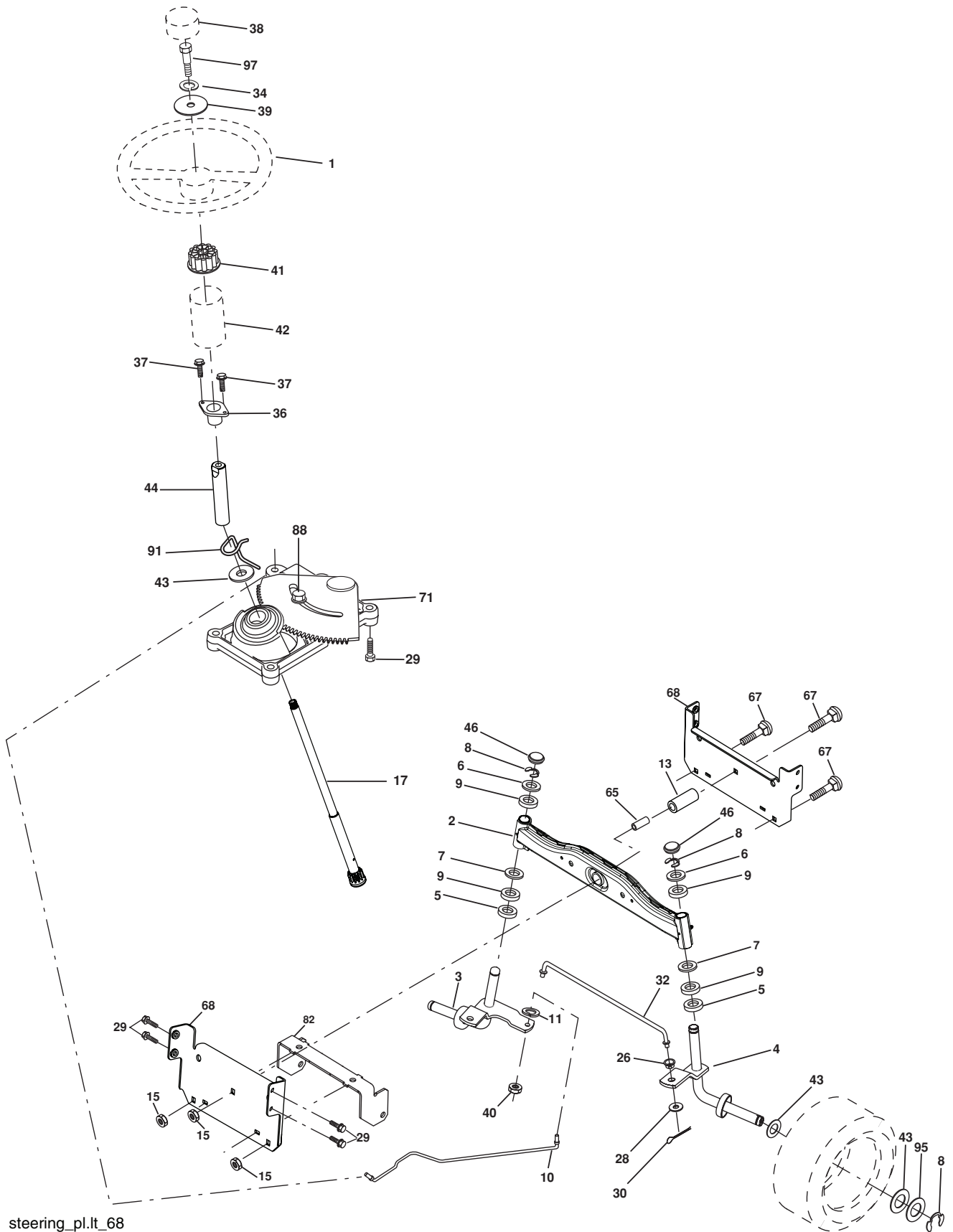

steering\_pl.lt\_68

# REPAIR PARTS

TRACTOR - - MODEL NUMBER FL12597 (96011018303), PRODUCT NO. 960 11 01-83  
STEERING

KEY NO.	PART NO.	DESCRIPTION
1	532 18 67-80	Wheel Steering
2	532 19 56-73	Axle Asm
3	532 16 98-40	Spindle Asm LH
4	532 16 98-39	Spindle Asm RH
5	532 12 49-31	Bearing Race Thrust Harden
6	532 12 17-48	Washer 25/32 x 1-5/8 x 16 Ga.
7	819 27 20-16	Washer 27/32 x 1-1/4 x 16 Ga.
8	812 00 00-29	Ring Klip #t5304-75
9	532 12 49-37	Bearing Col Strg Blk
10	532 17 51-21	Link Drag
11	810 04 06-00	Washer Lock Hvy Hlcl Spr 3/8
13	532 13 65-18	Spacer earing Axle Front
15	532 14 52-12	Hexflange Lock
17	532 19 07-53	Shaft Asm Strg
26	532 12 68-47	Bushing Link Drag Blk LR
28	819 13 14-16	Washer 13/32 x 7/8 x 16 Ga.
29	817 00 06-12	Screw 3/8-16 x 3/4
30	876 02 04-12	Pin Cotter 1/8 x 3/4 Cad
32	532 19 27-57	Rod Tie
34	810 04 05-00	Washer Lock Hvy Hlcl Spr. 5/16
36	532 15 50-99	Bushing Strg 5/8 Id Dash
37	532 15 29-27	Screw
38	532 19 29-16	Cap Wheel Steer
39	819 11 38-12	Washer 11/32 ID x 2-3/8OD 12 Ga.
40	873 54 06-00	Nut Crownlock 3/8-24
41	532 18 67-37	Adaptor Wheel Strg
42	532 16 96-33	Boot Steering
43	532 12 17-49	Washer 25/32 x 1 1/4 x 16 Ga.
44	532 19 07-52	Extension Steering
46	532 12 12-32	Cap Spindle Fr Top Blk
65	532 16 03-67	Spacer Brace Axle
67	872 11 06-18	Bolt RdHd Sqnk 3/8-16 x 2-1/4
68	532 16 98-27	Brace Axle
71	532 17 51-46	Steering Asm
82	532 19 99-78	Bracket Susp Chassis Front
88	532 17 51-18	Bolt shoulder 7/16-20
91	532 17 55-53	Clip Steering
95	532 18 89-67	Washer Hardened
97	874 78 05-64	Bolt 5/16-18 unc x 4" L Gr. 5

**NOTE:** All component dimensions given in U.S. inches  
1 inch = 25.4 mm.



# REPAIR PARTS

TRACTOR - - MODEL NUMBER FL12597 (96011018303), PRODUCT NO. 960 11 01-83  
ENGINE

KEY NO.	PART NO.	DESCRIPTION
1	532 17 05-51	Control Throttle /Choke
2	817 72 04-08	Screw Hex Thd Cut 1/4-20 x 5/8 T
3	-----	Engine Briggs Model <b>219807</b> (Order Parts from Engine Manufacturer)
4	532 17 97-58	Muffler Exhaust
13	532 16 52-91	Gasket
14	532 14 84-56	Tube Drain Oil Easy
23	532 16 98-37	Shield Browning/Debris Guard
25	532 19 06-95	Control Choke
29	532 13 71-80	Arrestor Spark
31	532 40 75-16	Tank Fuel
32	532 19 77-25	Cap Asm Fule Top
33	532 12 34-87	Clamp Hose Blk
37	532 13 70-40	Line Fuel 20"
38	532 18 16-54	Plug Drain Oil Easy
44	817 67 04-12	Screw Hexwsh Thdrol 3/8-16 x 3/4
45	817 00 06-12	Screw 3/8-16 x 3/4
46	819 09 14-16	Washer 9/32 x 7/8 x 16 Ga.
72	532 19 23-34	Screw Socket HD 5/16-18 x .75
78	817 06 06-20	Screw 3/8-16 x 1-1/4
81	873 51 04-00	Nut Keps Hex 1/4-20 unc

**NOTE:** All component dimensions given in U.S. inches  
1 inch = 25.4 mm.

## Engine Power Rating Information

The gross power rating for individual gas engine models is labeled in accordance with SAE (Society of Automotive Engineers) code J11940 (Small Engine Power & Torque Rating Procedure), and rating performance has been obtained and corrected in accordance with SAE J1995 (Revision 2002-5). Actual gross engine power will be lower and is affected by, among other things, ambient operating conditions and engine-to-engine variability. Given both the wide array of products on which engines are placed and the variety of environmental issues applicable to operating the equipment, the gas engine will not develop the rated gross power when used in a given piece of power equipment (actual "on-site" or net horsepower). This difference is due to a variety of factors including, but not limited to, accessories (air cleaner, exhaust, charging, cooling, carburetor, fuel pump, etc.), application limitations, ambient operating conditions (temperature, humidity, altitude), and engine-to-engine variability. Due to manufacturing and capacity limitations, Briggs & Stratton may substitute an engine of higher rated power for this Series engine.

# REPAIR PARTS

TRACTOR - - MODEL NUMBER FL12597 (96011018303), PRODUCT NO. 960 11 01-83  
MOWER DECK

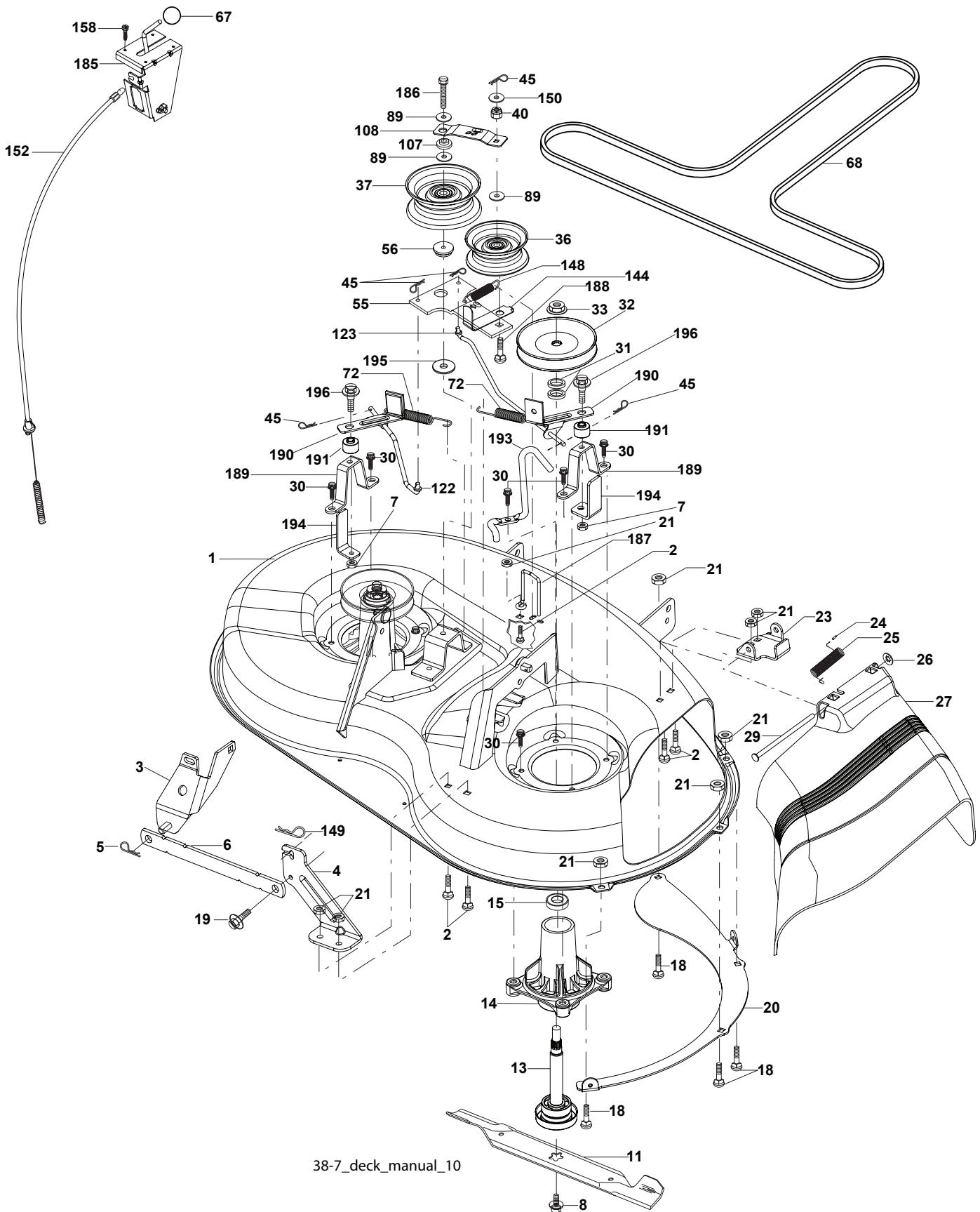

38-7\_deck\_manual\_10

# REPAIR PARTS

**TRACTOR - - MODEL NUMBER FL12597 (96011018303), PRODUCT NO. 960 11 01-83  
MOWER DECK**

KEY NO.	PART NO.	DESCRIPTION
1	532 19 25-56	Mower Housing Assembly
2	872 14 05-06	Bolt Carriage 5/16-18 x 3/4
3	532 13 80-17	Bracket Asm Fr. Sway Bar
4	532 19 25-68	Bracket Deck Sway Bar 38"/42"
5	532 12 46-70	Retainer Spring
6	532 17 80-24	Bar Sway Deck
7	873 80 05-00	Nut Lock Hex W/Ins 5/16-18 UNC
8	532 19 30-03	Bolt 3/8-24 x 1.25 Gr. 8
11	532 19 39-57	Blade Mower
13	532 19 28-72	Shaft Assembly, Mandrel, Vented
14	532 18 72-81	Housing, Mandrel, Vented
15	532 11 04-85	Bearing, Ball, Mandrel
18	872 14 05-05	Bolt Rdhd Sqnk 5/16-18 x 5/8
19	532 13 28-27	Bolt, Shoulder
20	532 40 00-95	Baffle Vortex Front
21	873 68 05-00	Nut
23	532 19 25-57	Bracket, Mower Deflector
24	532 10 53-04	Cap, Sleeve
25	532 19 70-26	Spring, Torsion, Deflector
26	532 11 04-52	Nut, Push
27	532 40 14-72	Shield, Deflector
29	532 13 14-91	Rod, Hinge
30	532 17 39-84	Screw Thdrol.
31	532 18 76-90	Washer, Spacer
32	532 15 35-32	Pulley, Mandrel
33	532 40 02-34	Nut, Toplock
36	532 13 14-94	Pulley, Idler, Flat
37	532 19 31-98	Pulley Idler Flat
40	873 68 06-00	Nut, Crownlock 3/8-16 unc
45	532 12 47-88	Retainer
55	532 13 38-40	Idler Arm Assembly
56	532 16 57-23	Spacer, Retainer
67	532 10 69-32	Knob
68	532 19 32-14	V-Belt

KEY NO.	PART NO.	DESCRIPTION
72	532 19 32-16	Spring Brake Return
89	819 13 13-11	Washer 13/32 x 13/16 x 11 Ga.
107	532 13 35-02	Spacer Retainer
108	532 13 35-03	Stiffener, Idler Arm
122	532 41 01-89	Rod, Brake LH Link
123	532 41 01-90	Rod, Brake RH Link
144	532 19 34-14	Keeper Belt Idler Tension
148	532 16 90-22	Spring Return Idler
149	532 16 58-98	Retainer Spring Yellow
150	819 09 12-10	Washer 9/32 x 3/4 x 10 Ga.
152	532 19 32-35	Clutch Cable 38"/46"
158	817 72 04-08	Screw Hex Thd Cut 1/4-20 x 1/2
185	532 18 82-34	Head Asm Cable Clutch
186	817 49 06-44	Screw Hex Wsh Thdrol 3/8-16 x 2-3/4
187	532 19 34-12	Keeper Belt
188	532 16 58-91	Bolt Carriage Idler
189	532 19 25-59	Stand, Brake
190	532 19 25-60	Arm, Brake
191	532 19 25-61	Spacer, Brake
193	532 19 34-13	Keeper Belt Rh Mandrel
194	532 19 41-05	Guard Brake
195	819 13 32-10	Washer
196	532 19 37-82	Bolt/Washer Asm 5/16-18
--	532 19 25-58	Brake Assembly (Includes Stand, Arm and Guard Components)
--	532 19 28-70	Mandrel Assembly (Includes Hous- ing, Shaft and Shaft Hardware Only - Pulley Not Included)
--	532 19 36-46	Replacement Mower, Complete

**NOTE:** All component dimensions given in U.S. inches  
1 inch = 25.4 mm.

# REPAIR PARTS

TRACTOR - - MODEL NUMBER FL12597 (96011018303), PRODUCT NO. 960 11 01-83  
MOWER LIFT

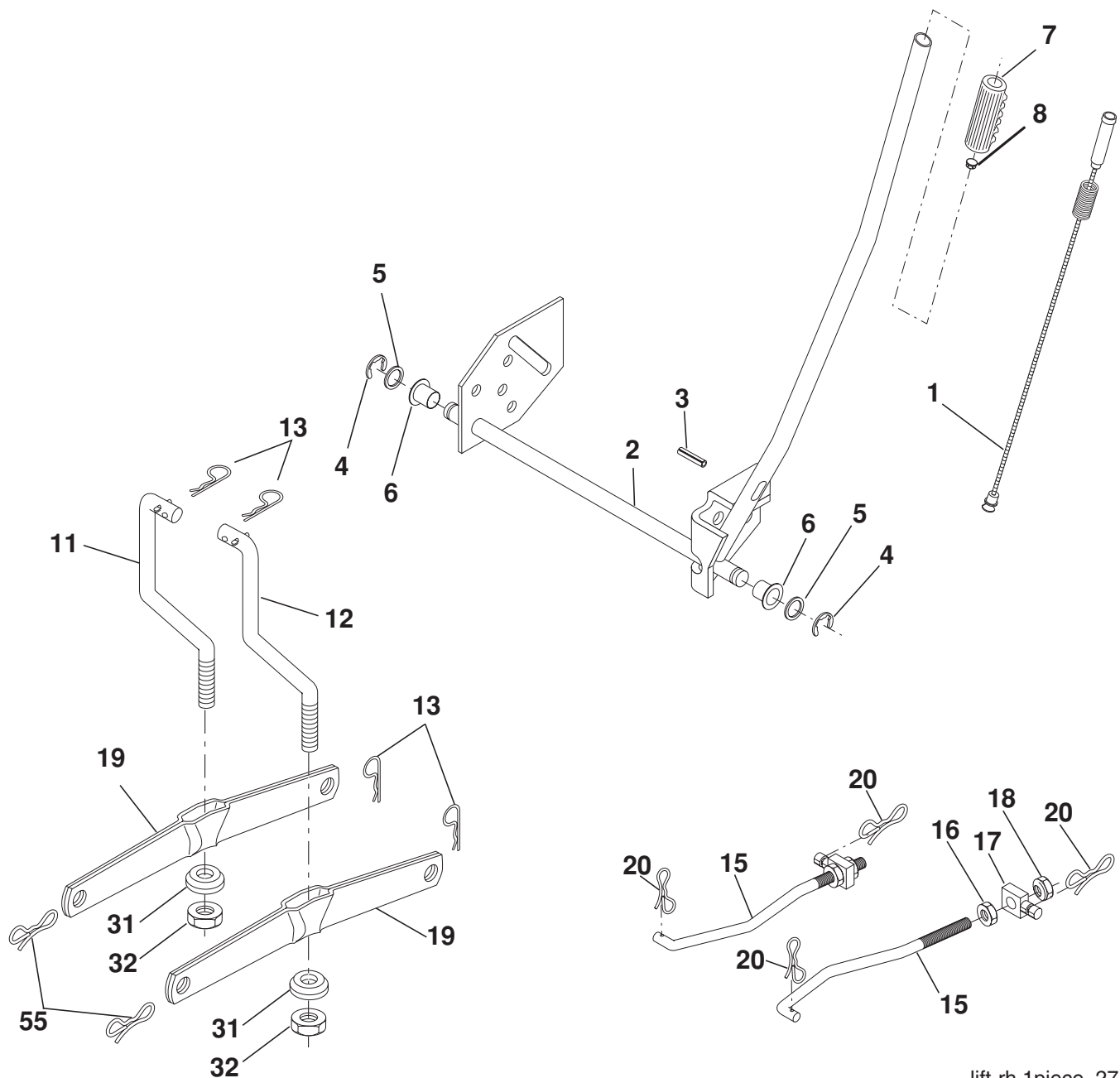

lift-rh.1piece\_27

KEY NO.	PART NO.	DESCRIPTION
1	532 15 94-60	Wire Asm Inner/Sprg w/plunger
2	532 15 94-71	Shaft Asm Lift RH
3	532 10 57-67	Pin Groove
4	812 00 00-02	E Ring #5133-62
5	819 21 16-21	Washer 21/32 x 1 x 21 Ga.
6	532 12 01-83	Bearing Nylon Blk 629 Id
7	532 10 94-13	Grip Handle Bicycle Matte Blk
8	532 12 45-26	Button Plunger Black
11	532 13 98-65	Link Lift LH Fixed Length
12	532 13 98-66	Link Lift RH Fixed Length
13	532 12 46-70	Retainer Spring

KEY NO.	PART NO.	DESCRIPTION
15	532 17 32-88	Link Front
16	873 35 08-00	Nut Jam Hex 1/2-13 unc
17	532 17 56-89	Trunnion
18	873 80 08-00	Nut Lockw/Wsh 1/2-13 unc
19	532 13 98-68	Arm Suspension Rear
20	532 19 42-09	Pin Cotter 7/16 Bow Tie Lock
31	532 16 98-65	Bearing Pvt Lift
32	873 54 06-00	Nut Crownlock 3/8-24
55	532 19 42 08	Pin Cotter 5/16 Bowtie Lock

**NOTE:** All component dimensions given in U.S. inches  
1 inch = 25.4 mm.

# REPAIR PARTS

TRACTOR - - MODEL NUMBER FL12597 (96011018303), PRODUCT NO. 960 11 01-83  
SEAT

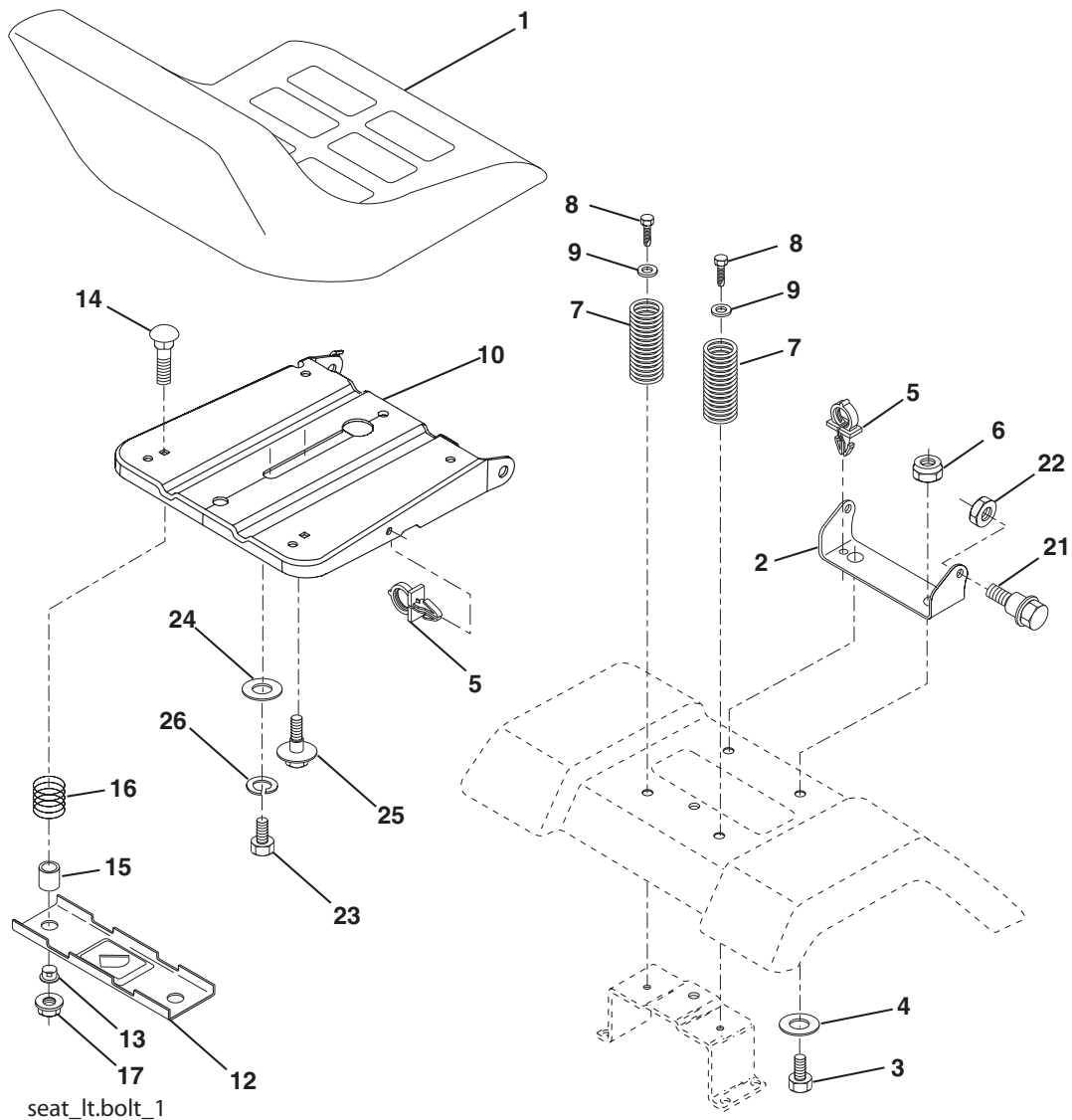

seat\_lt.bolt\_1

KEY NO.	PART NO.	DESCRIPTION
1	532 40 10-42	Seat
2	532 14 05-51	Bracket Seat Pivot
3	871 11 06-16	Bolt Hex 3/8 - 16 x 1
4	819 13 16-10	Washer 13/32 x 1 x 10 Ga.
5	532 14 50-06	Clip Push-In Hinged
6	873 80 06-00	Nut Lock Hex w/Ins 3/8 - 16
7	532 12 41-81	Spring Seat Cprsn 2 250 Blk Zi
8	817 00 06-16	Screw 3/8-16 x 1.5
9	819 13 16-14	Washer 13/32 x 1 x 14 Ga.
10	532 19 55-30	Pan Pnt Seat (Blk)
12	532 17 46-48	Bracket Pnt Mounting Switch
13	532 12 12-48	Bushing Snap Blk Nyl

KEY NO.	PART NO.	DESCRIPTION
14	872 05 04-12	Bolt Rdhd Sht Nk 1/4 - 20 x 1 -1/2
15	532 13 43-00	Spacer Split .28 x .96
16	532 12 12-50	Spring Cprsn
17	532 12 39-76	Nut Lock 1/4 Lge Flg
21	532 17 18-52	Bolt Shoulder 5/16-18 unc-2A
22	873 80 05-00	Nut Lock Hex w/Ins 5/16 - 18
23	871 11 08-14	Bolt Hex Black
24	819 17 19-12	Washer 17/32 x 1-3/16 x 12 Ga.
25	532 12 70-18	Bolt Shoulder 5/16-18 x .62
26	810 04 08-00	Washer Lock Hvy Hlcl Spr 1/2

**NOTE:** All component dimensions given in U.S. inches  
1 inch = 25.4 mm.