

REPAIR PARTS MANUAL
MODEL NO. 165H107RB (BA165H107RBA)
Lawn Tractor

 McCULLOCH®

HOW TO USE THIS MANUAL

This manual is designed to provide the customer with a means to identify the parts on his/her tractor when ordering repair parts. The illustrations may or may not represent the actual assemblies; therefore, it is not recommended to use this manual as a guide to assemble or disassemble the tractor. Some hardware and parts are drawn larger in order to more readily identify them.

Each tractor has its own model number.

The model number for your tractor can be found on the fender under the seat.

When ordering parts, always give the following information:

- Product - "Tractor"
- Model Number - "165H107RB" (BA165H107RBA)
- Part Number
- Part Description

TABLE OF CONTENTS

SCHEMATIC	3
ELECTRICAL	4-5
CHASSIS	6-7
DRIVE	8-9
STEERING	10-11
SEAT	12
DECALS	13
ENGINE	14-15
MOWER LIFT	16-17
MOWER DECK	18-19
BAGGER	20-21

TRACTOR- -MODEL NO. 165H107RB (BA165H107RBA), PRODUCT 964 77 48-00 SCHEMATIC

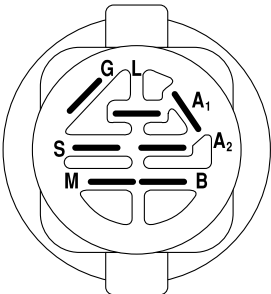
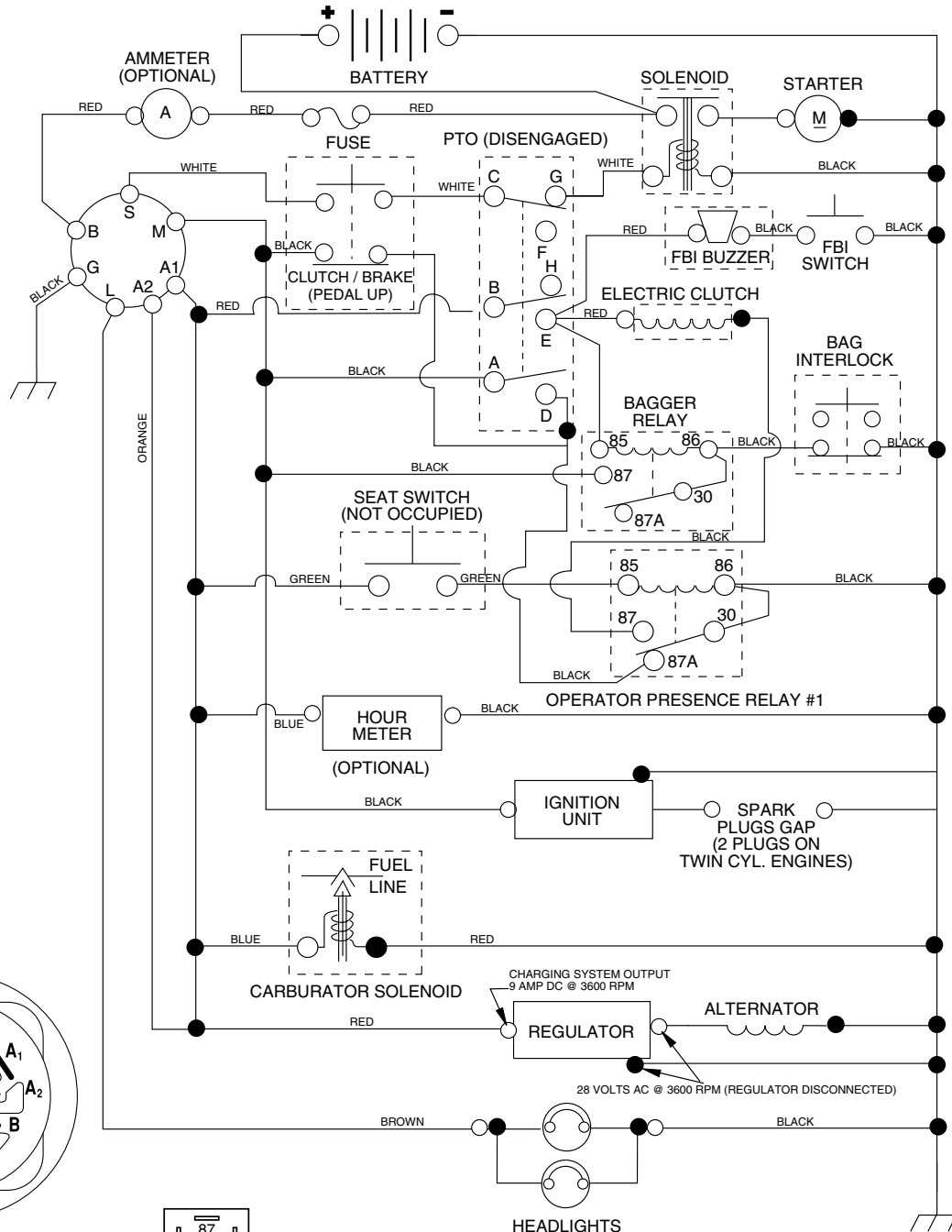

IGNITION SWITCH

POSITION	CIRCUIT	"MAKE"
OFF	M+G+A1	NONE
RUN/LIGHT	B+A1	A2+L
RUN	B+A1	NONE
START	B + S + A1	NONE

WIRING INSULATED CLIPS
NOTE: IF WIRING INSULATED CLIPS WERE REMOVED FOR SERVICING OF UNIT, THEY SHOULD BE REPLACED TO PROPERLY SECURE YOUR WIRING.

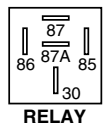

RELAY

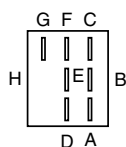

PTO SWITCH

POSITION	CIRCUIT
OFF	C + G, B + H
ON	C + F, B + E, A + D

●
NON-REMOVABLE CONNECTIONS

○
REMOVABLE CONNECTIONS

REPAIR PARTS

TRACTOR- -MODEL NO. 165H107RB (BA165H107RBA), PRODUCT 964 77 48-00
ELECTRICAL

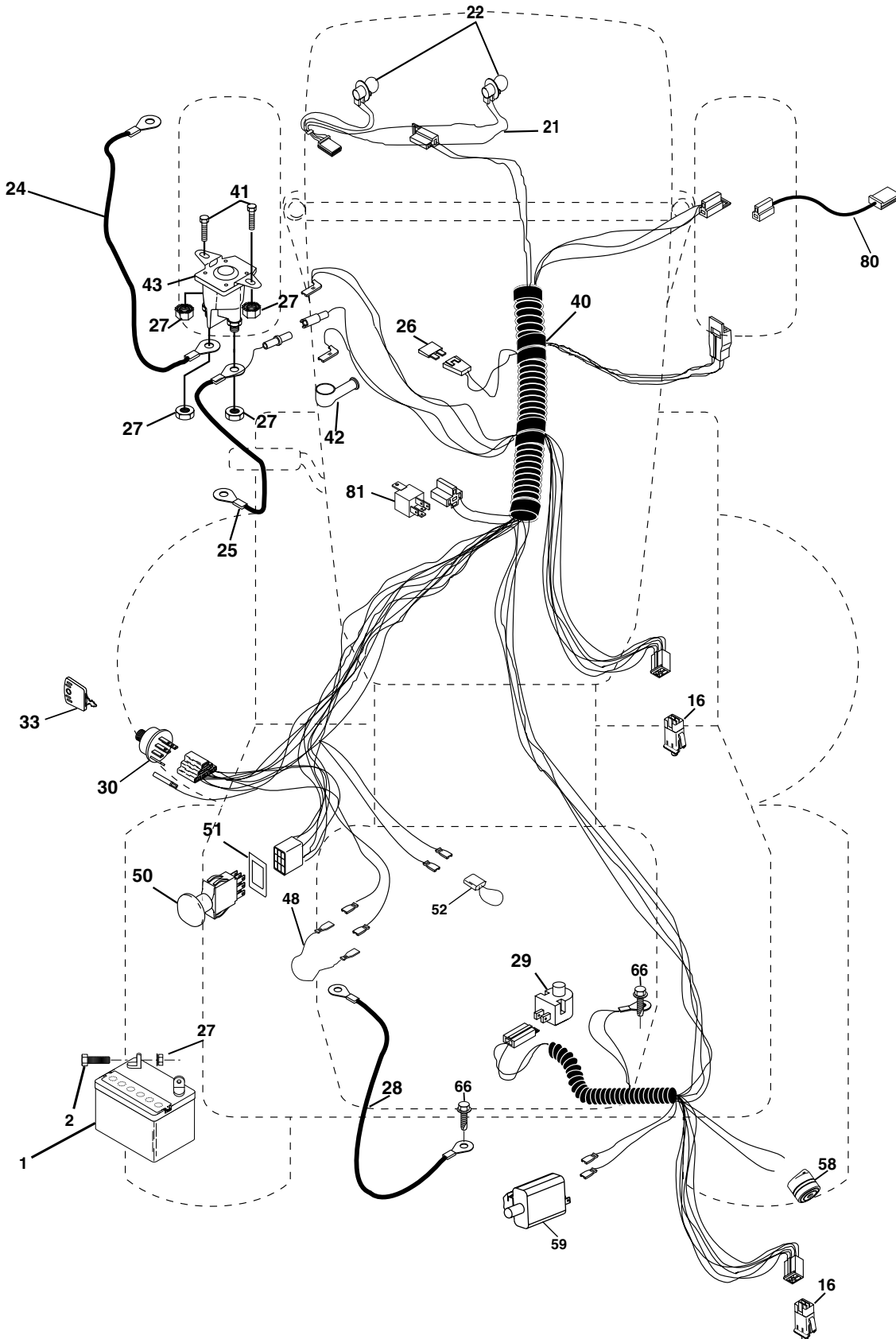

REPAIR PARTS

TRACTOR- -MODEL NO. 165H107RB (BA165H107RBA), PRODUCT 964 77 48-00
ELECTRICAL

KEY NO.	PART NO.	DESCRIPTION
1	532 16 34-65	Battery
2	874 76 04-12	Bolt Hex Hd 1/4-20 Unc X 3/4
16	532 17 61-38	Switch Interlock
21	532 17 56-85	Harness Asm Light W/4152J
22	532 00 41-52	Bulb Light #1156
24	532 12 47-80	Cable Starter 6Ga 11" Red
25	532 16 59-87	Cable Battery Crd 56" Red
26	532 17 51-58	Fuse
27	873 51 04-00	Nut Keps Hex 1/4-20 Unc
28	532 12 77-25	Cable Ground 6Ga 18" Black
29	532 16 07-84	Switch Plunger Normal Op Olive
30	532 17 55-66	Switch Ignition
33	532 14 04-01	Key Ign
40	532 17 97-27	Harness Ign
41	871 11 04-08	Bolt Flk Fin Hex 1/4-20 Unc X 1/2
42	532 13 15-63	Cover Terminal Red
43	532 17 88-61	Solenoid
48	532 14 08-44	Adapter Ammeter Rectangular
50	532 17 46-51	Switch PTO
51	532 14 04-05	Ring Retainer PTO
52	532 14 19-40	Protection Wire Loop
58	532 16 94-19	Buzzer Crd
59	532 18 03-79	Switch FBI CRD
66	817 49 06-08	Screw Thdrol 3/8-16 x 1/2 Ty-Tt
81	532 10 97-48	Relay Asm

NOTE: All component dimensions given in U.S. inches.
1 inch = 25.4 mm.

REPAIR PARTS

TRACTOR- -MODEL NO. 165H107RB (BA165H107RBA), PRODUCT 964 77 48-00 CHASSIS AND ENCLOSURES

KEY NO.	PART NO.	DESCRIPTION
1	532 17 46-20	Chassis
2	532 18 03-84	Drawbar
3	817 06 06-12	Screw 3/8-16 x .75
5	532 15 52-72	Bumper Hood/Dash
6	532 15 59-23	Saddle
8	532 12 64-71	Clip Insulator 13/32 Mtg. Hole
9	532 17 20-99	Dash
10	872 14 06-08	Bolt, Carriage 3/8-16 x 3/4
11	532 17 49-96	Panel, Dash, L.H.
12	532 14 56-60	Clip Tinnerman Grille P/L
13	532 17 21-06	Panel, Asm. Dash R.H.
15	874 18 05-12	Screw, Machine, Truss Head 5/16-18 UNC x 3/4
16	873 51 05-00	Nut
17	532 18 25-05	Hood Assembly
18	532 12 69-38	Bumper Hood
20	532 18 06-79	Plate Mtg. Battery/Fuel Tank
24	874 78 06-16	Bolt
25	819 13 13-12	Washer 13/32 x 13/16 x 12 Gauge
26	873 80 06-00	Nut
28	532 17 91-01	Grille Lens Asm
29	532 16 81-54	Lens
30	532 18 25-06	Fender
31	532 16 51-56	Bracket, Fender Support
33	532 18 25-07	Footrest, L.H.
34	532 18 25-08	Footrest, R.H.
35	872 11 06-06	Bolt
37	817 49 05-08	Screw Thdrol 5/16-18 x 1/2 TYT
38	532 18 17-48	Bracket Asm Pivot Mower Rear
51	873 80 04-00	Nut Lock w/Insert 1/4-20 UNC
52	819 09 14-16	Washer 9/32 x 7/8 x 16 Ga.
53	532 14 46-97	Bracket Grille Lh
54	532 16 14-64	Screw Hex Wshd 8-18 x 7/8
55	532 14 46-96	Bracket Grille Rh
57	874 78 04-12	Bolt, Fin Hex 1/4-20 UNC x .75

KEY NO.	PART NO.	DESCRIPTION
58	532 15 01-27	Duct Air Engine Pl/Lt
69	532 14 24-32	Screw Hex 1/4-1/2
89	532 18 13-60	Console
145	532 15 65-24	Rod Pivot Chassis/Hood
161	532 16 46-55	Bumper Extrusion
162	532 18 03-82	Bracket Exten Chassis Lh CRD
163	532 18 03-83	Bracket Exten Chassis Rh CRD
164	532 16 56-05	Support Battery CRD
165	532 18 13-56	Cover Battery CRD Lt
170	532 17 88-62	Backplate Asm CRD
171	872 14 06-20	Bolt Rdhd Sqnk 3/8-16 x 2-1/2 G5
172	819 13 20-16	Washer 13/32 x 1-1/4 x 16 Ga.
173	873 51 06-00	Nut, Keps Hex 3/8-16 UNC
175	532 18 03-10	Trap Door CRD
179	532 18 03-76	Rod Pivot FBI CRD
184	532 17 46-62	Bracket Actuator Bagger CRD
185	532 18 11-01	Knob Rod
186	532 16 07-93	Latch Asm Multch Bagger
187	532 12 50-04	Nut Weld .327/.304 #10-24
188	819 06 12-16	Washer #10
189	810 07 10-00	Washer Lock #10
190	871 08 10-10	Screw Pan Hd Phillips 10-24 x 5/8
198	532 16 89-37	Nut Push
205	817 49 06-08	Screw 3/8-16 x 1/2
208	817 67 06-08	Screw Thdrol 3/8-16 x 1/2
209	817 00 06-12	Screw Hex Wsh Thdrol 3/8-16 x 3/4
212	532 15 62-29	Insert Lens Reflective
214	532 12 47-88	Retainer Spring 1"
215	817 06 05-08	Screw 5/16-18 x 1/2
219	817 00 05-12	Screw 5/16 -18 x 3/4
256	532 18 13-61	Cover Fender Rack CRD
--	532 00 54-79	Plug, Button

NOTE: All component dimensions given in U.S. inches.
1 inch = 25.4 mm.

REPAIR PARTS

TRACTOR- -MODEL NO. 165H107RB (BA165H107RBA), PRODUCT 964 77 48-00
DRIVE

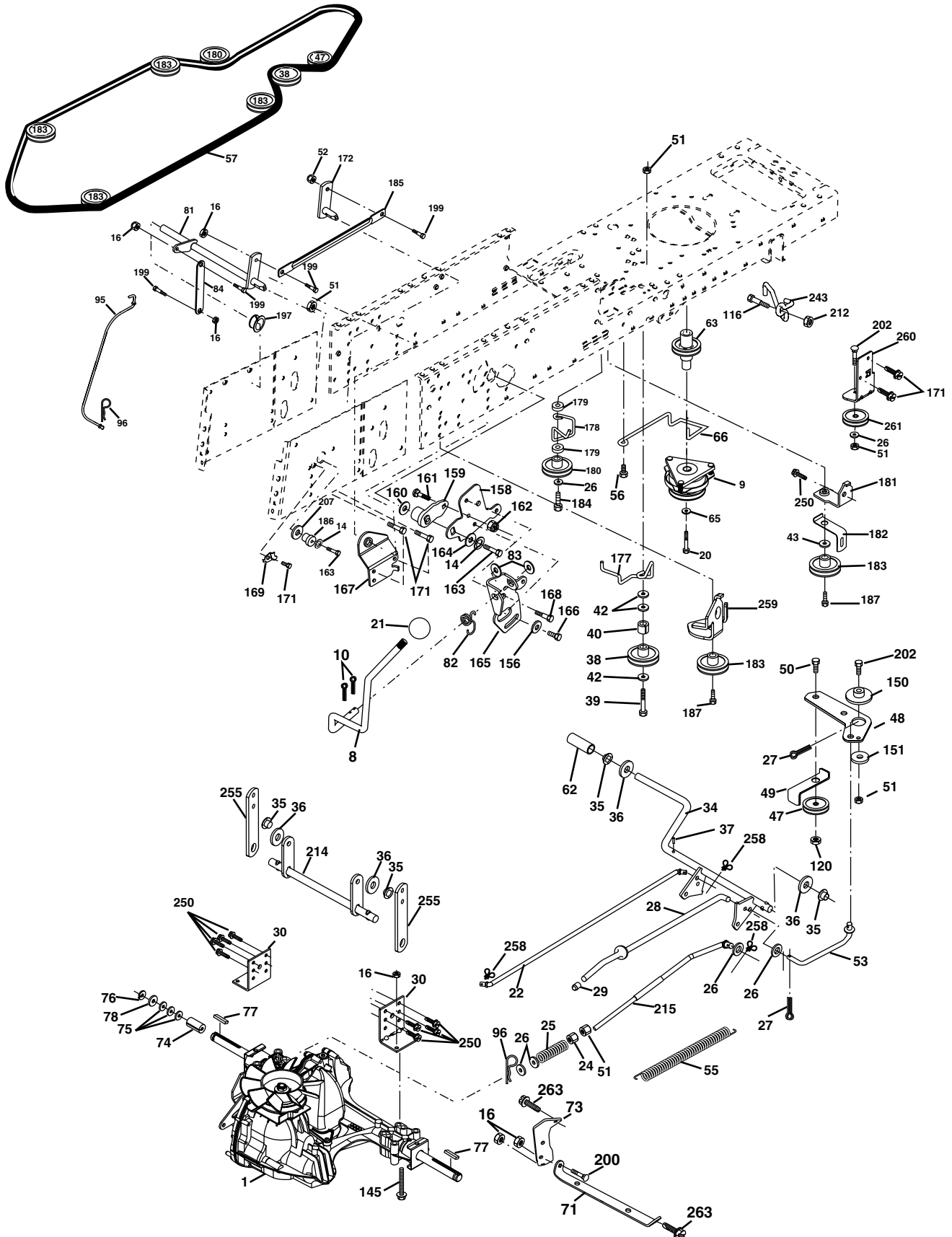

REPAIR PARTS

TRACTOR- -MODEL NO. 165H107RB (BA165H107RBA), PRODUCT 964 77 48-00 DRIVE

KEY NO.	PART NO.	DESCRIPTION	KEY NO.	PART NO.	DESCRIPTION
1	-----	Transaxle Hydro Gear 321-0510 (Order parts from transaxle manufacturer)	84	532 17 00-07	Link, Transaxle
8	532 18 25-14	Rod, Shift Fender Adjust Lt	95	532 17 00-15	Control Asm Bypass Hydro
9	532 18 02-20	Clutch Elec.	96	532 12 47-88	Spring, Retainer 1"
10	876 02 04-16	Pin, Cotter 1/8 x 1	116	872 14 06-08	Bolt RDHD Spnk 3/8-16 x 1
14	810 04 04-00	Washer, Lock Hvy Helical	120	873 90 06-00	Nut Lock Fig. 3/8-16 Unc
16	873 80 05-00	Nut, Lock Hex w/Ins 5/16-18 UNC	145	874 49 05-44	Bolt Hex FGHD 5/16-18 x Gr 5
20	871 17 07-64	Bolt Hex 7/16-20 x 4 x Gr. 5	150	532 16 58-50	Bushing, Bellcrank Grnd Dr
21	532 14 08-45	Knob	151	819 13 32-10	Washer 13/32 x 2 x 10 Ga.
22	532 17 56-07	Rod, Brake	156	532 16 60-02	Washer Srted 5/16ID x 1.125
23	532 18 03-02	Bracket asm Anti-Rot	158	532 16 55-89	Bracket Shift Mount
24	873 35 06-00	Nut	159	532 16 54-94	Hub Tapered Flange Shift Lt
25	532 10 68-88	Spring, Rod, Brake	160	819 29 20-16	Washer 29/32 x 1-1/4 x 16 Ga.
26	819 13 13-16	Washer 13/32 x 13/16 x 16 Ga.	161	872 14 04-06	Bolt Rdhd Sqnk 1/4-20 x 3/4 Gr 5
27	876 02 04-12	Pin, Cotter 1/8 x 3/4	162	873 68 04-00	Nut Crownlock 1/4-20 Unc
28	532 17 57-65	Rod, Parking Brake	163	874 78 04-16	Bolt Hex Fin 1/4-20 Unc x 1 Gr 5
29	532 07 16-73	Cap, Parking Brake	164	819 09 10-10	Washer 5/8 x .281 x 10 Ga.
30	532 16 95-92	Bracket, Mfg. Transaxle	165	532 16 56-23	Bracket Pivot Lever
34	532 17 55-78	Shaft, Asm Pedal Foot CRD	166	532 16 68-80	Screw 5/16-18 x 5/8
35	532 12 01-83	Bearing, Nylon	167	532 16 55-88	Bracket Support Shift CRD
36	819 21 16-16	Washer 21/32 x 1 x 16 Ga.	168	532 16 54-92	Bolt Shoulder 5/16-18 x .561
37	532 12 49-63	Pin, Roll 3/16 x 1"	169	532 16 55-80	Plate Fastening Lt
38	532 16 59-36	Pulley Flat Composite 3.06"	171	817 49 06-08	Screw Thdrol 3/8-16 x 1/2 Ty-Tt
39	874 76 06-44	Bolt Fin Hex 3/8-16 Unc x 2-3/4	172	532 17 02-71	Shaft Asm Shifter Frt CRD
40	532 12 49-65	Spacer, Split 395 x 59 Bzp	177	532 16 59-32	Keeper Flat Idler 3.06" CRD
42	819 13 13-12	Washer 13/32 x 13/16 x 12 Ga.	178	532 16 59-33	Keeper Belt Idler 1.88" CRD
43	819 11 10-12	Washer 11/32 x 5/8 x 12 Ga	179	532 12 09-58	Washer Sintered
47	532 12 77-83	Pulley, Idler, V Groove Plasitc	180	532 16 56-30	Pulley, Idler, Flat 1.88"CRD
48	532 15 44-07	Bellcrank Clutch Grnd Drv	181	532 18 02-11	Bracket Idler Ground Drive CRD
49	532 12 32-05	Retainer, Belt Style Spring	182	532 16 56-34	Keeper Belt 2.5" Od V-Idler CRD
50	874 76 06-24	Bolt Hex Hd 3/8-16 UNC x 1-1/2	183	532 17 90-50	Pulley V-Idler 2.50" Od CRD
51	873 68 06-00	Nut, Crownlock 3/8-16 UNC	184	817 49 06-44	Screw Hexwsh Thdrol 3/8-16 x 2-3/4
52	873 68 05-00	Nut Crownlock 5/16-18	185	532 17 00-08	Link Shift
53	532 10 57-10	Link, Clutch 7.66	186	532 16 56-14	Hub Tapered Round CRD
55	532 10 57-09	Spring, Return, Clutch	187	817 58 05-20	Screw Thdrol 5/16-18 x 1.25
56	817 06 06-20	Screw 3/8-16 x 1-1/4	197	532 16 96-13	Nyliner Snap-In 5/8
57	532 17 01-40	V-Belt Key 112" 0650 CRD	199	532 16 96-12	Bolt Shoulder 5/16-18 Unc
62	532 12 48-72	Cover, Pedal	200	872 14 05-08	Bolt RDHD SQNK 5/16-18 x 1
63	532 18 03-97	Pulley Engine	202	872 11 06-14	Bolt Carr. Sh. 3/8-16 x 1-3/4 Gr. 5
65	810 04 07-00	Washer	203	871 17 07-80	Bolt Hex 7/16-20 x 5
66	532 15 47-78	Keeper, Belt Engine F-Proof	207	532 16 98-45	Washer Nylon Rear
71	532 16 91-83	Strap, Torque, Lh	212	532 14 52-12	Nut Hex Flange Lock
73	532 16 91-82	Strap, Torque, Rh	214	532 17 56-09	Shaft Asm. Brake
74	532 13 70-57	Spacer, Split	215	532 17 56-52	Rod Brake Hydro
75	532 12 17-49	Washer 25/32 x 1-1/4 x 16 Ga.	243	532 17 82-89	Bracket Anti-Rotate
76	812 00 00-01	Ring, E	250	817 06 06-12	Screw 3/8-16 x .75
77	532 12 35-83	Key, Square	255	532 17 56-08	Brace Shaft Brake Mtg.
78	532 12 17-48	Washer 25/32 x 1-5/8 x 16 Ga.	258	532 17 80-62	Clip Retainer
81	532 17 00-06	Asm, Shaft	259	532 18 02-12	Bracket Pulley
82	532 16 57-11	Spring, Torsion	260	532 18 17-81	Bracket Idler Chassis
83	819 17 12-16	Washer 17/32 x 3/4 x 16 Ga.	261	532 13 14-94	Pulley Idler Flat

NOTE: All component dimensions given in U.S. inches
1 inch = 25.4 mm

REPAIR PARTS

TRACTOR- -MODEL NO. 165H107RB (BA165H107RBA), PRODUCT 964 77 48-00
STEERING ASSEMBLY

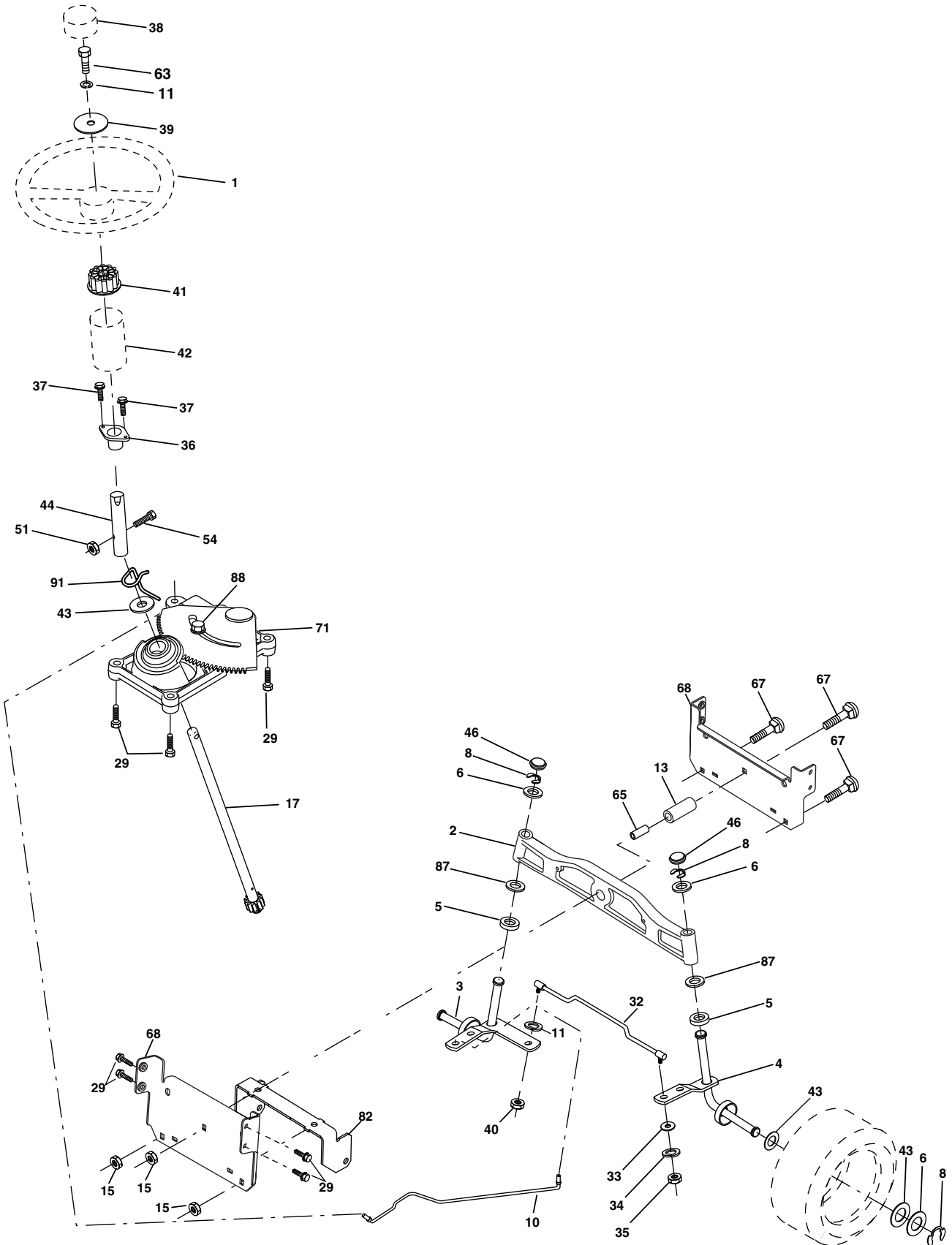

REPAIR PARTS

TRACTOR- -MODEL NO. 165H107RB (BA165H107RBA), PRODUCT 964 77 48-00 STEERING ASSEMBLY

KEY NO.	PART NO.	DESCRIPTION
1	532 17 20-92	Steering Wheel
2	532 17 23-93	Cast Iron Axle Assembly
3	532 16 98-40	Spindle Assembly, L.H.
4	532 16 98-39	Spindle Assembly, R.H.
5	532 12 49-31	Bearing, Race, Thrust, Hardened
6	532 12 17-48	Washer 25/32 x 1-5/8 x 16 Gauge
8	812 00 00-29	Ring, Klip
10	532 17 51-21	Link, Drag
11	810 04 06-00	Washer, Lock
13	532 13 65-18	Spacer Brg Axle Front
15	532 14 52-12	Nut, Hexflange Lock
17	532 17 78-76	Shaft Assembly, Steering
29	817 06 06-12	Screw, 3/8-16 x 3/4
32	532 17 18-88	Rod, Tie
33	819 11 12-16	Washer 11/32 x 3/4 x 16 Ga
34	810 04 05-00	Washer Lock Hvy Hlcl Spr 5/16
35	873 54 05-00	Nut Crownlock 5/16-24 Unf
36	532 15 50-99	Bushing, Steering
37	532 15 29-27	Screw TT #10-32 x 5 x 3/8 Flange
38	532 17 20-93	Cap Wheel Steer
39	819 13 24-11	Washer 13/32 x 1-1/20 x 11 Ga
40	532 12 47-01	Nut Lock Center 3/8-24 Unf
41	532 15 99-45	Adaptor, Steering Wheel
42	532 16 96-33	Boot, Steering Dash P/L Mtl
43	532 12 17-49	Washer 25/32 x 1-1/4 x 16 Gauge
44	532 15 37-20	Extension Steering Non-Adjust
46	532 12 12-32	Cap, Spindle
51	873 80 05-00	Nut Lock Hx W/Ins 5/16-18 UNC
54	874 78 05-20	Bolt Fin Hex 5/16-18 UNC x 1-1/4
63	874 78 06-16	Bolt Fin Hex 3/8-16 unc. x 1 Gr. 5
65	532 16 03-67	Spacer Brace Axle
67	872 14 06-18	Bolt Rdhd Sq 3/8-16 UNC x 2-1/4
71	532 17 51-46	Steering Asm.
68	532 16 98-27	Brace Axle
82	532 16 98-35	Bracket Susp Chassis Front
87	532 17 39-66	Washer Flat .781 x 1-1/2 x .14
88	532 17 51-18	Bolt Shoulder 7/16-20 Unc
91	532 17 55-53	Clip Steering

NOTE: All component dimensions given in U.S. inches.
1 inch = 25.4 mm.

REPAIR PARTS

TRACTOR- -MODEL NO. 165H107RB (BA165H107RBA), PRODUCT 964 77 48-00 SEAT ASSEMBLY

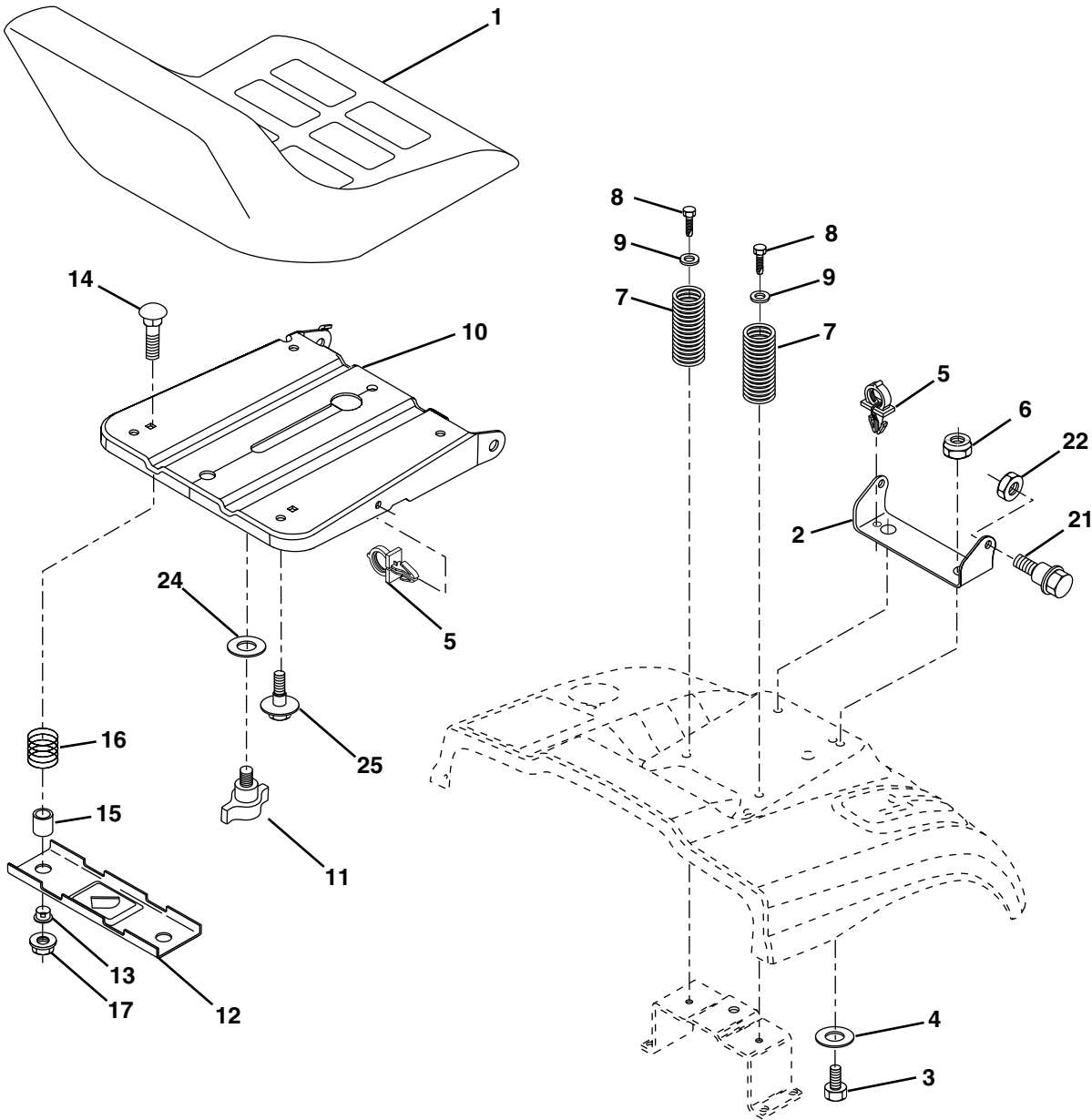

KEY NO.	PART NO.	DESCRIPTION
1	532 14 01-17	Seat
2	532 14 05-51	Bracket Pnt Pivot Seat (blk)
3	871 11 06-16	Bolt Fin Hex 3/8-16 Unc x 1
4	819 13 16-10	Washer Flat 13/32 x 1 x 10 Ga.
5	532 14 50-06	Clip Push In Hinged
6	873 80 06-00	Nut Lock Hex 3/8-16 Unc
7	532 12 41-81	Spring Seat Cprsn 2 250 Blk Zi
8	817 00 06-16	Screw 3/8-16 X 1-1/2
9	819 13 16-14	Washer 13/32 X 1 X 14 Ga
10	532 17 48-94	Pan Pnt Seat (blk)
11	532 16 63-69	Knob Seat Adj Wingnut
12	532 12 12-46	Bracket Pnt Mounting Switch

KEY NO.	PART NO.	DESCRIPTION
13	532 12 12-48	Bushing Snap Blk Nyl 50 Id
14	872 05 04-12	Bolt Rdhd Sht Nk 1/4-20x1-1/2
15	532 13 43-00	Spacer Split
16	532 12 12-50	Spring Cprsn Plate SW 1.310 Ga
17	532 12 39-76	Nut Lock 1/4 Lge Flg Gr 5 Zinc
21	532 17 18-52	Bolt Shoulder 5/16-18 Unc-2A
22	873 80 05-00	Nut Hex Lock w/Ins 5/16-18
24	819 17 19-12	Washer 17/32 X 1-3/16 X 12 Ga.
25	532 12 70-18	Bolt Shoulder 5/16-18 X 62

NOTE: All component dimensions given in U.S. inches.
1 inch = 25.4 mm

REPAIR PARTS

TRACTOR- -MODEL NO. 165H107RB (BA165H107RBA), PRODUCT 964 77 48-00
DECALS

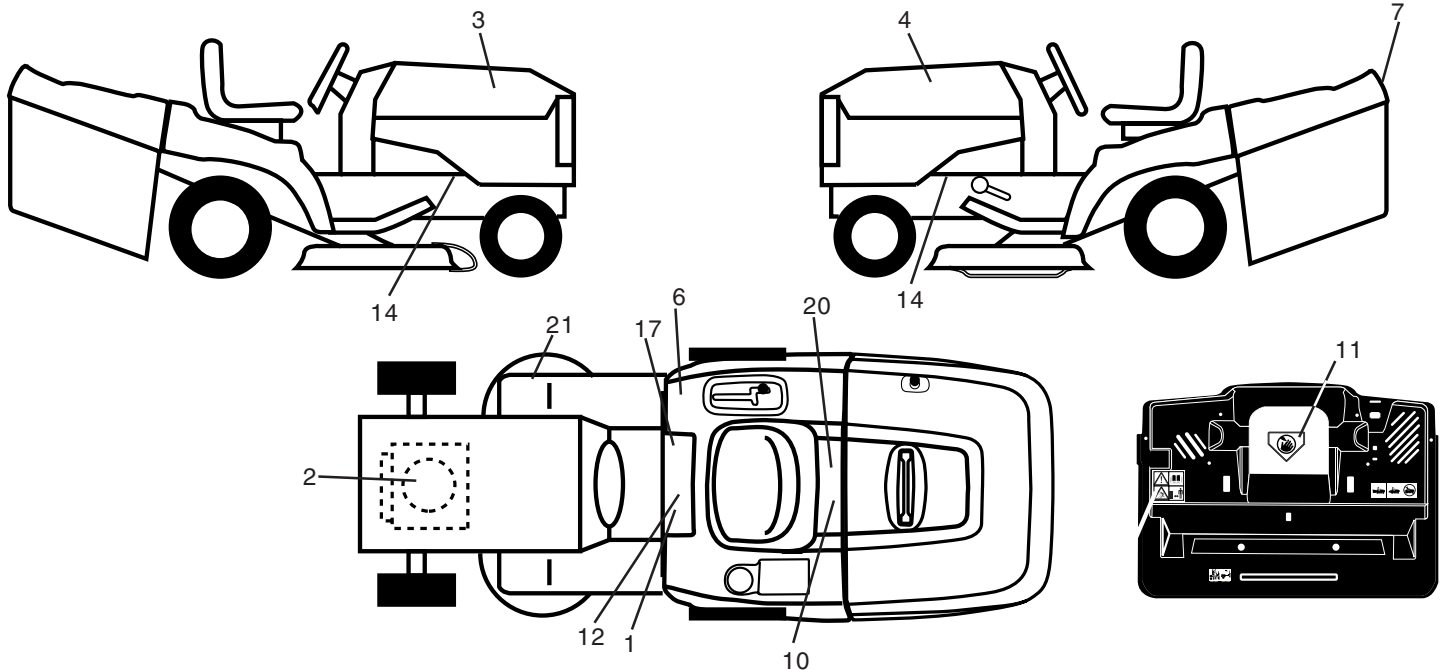

KEY NO.	PART NO.	DESCRIPTION
1	532 14 54-98	Decal Read Owner's Manual Sym
2	532 18 06-62	Decal Hp Engine
3	532 18 16-56	Decal Hood RH
4	532 18 16-57	Decal Hood LH
6	532 18 04-32	Decal 100 DBA/CE
7	532 18 16-23	Decal Bagger
10	532 14 50-05	Decal Bat Dan/Poi P/L Sym Wpn
11	532 18 21-66	Decal Mower Cut Finger Symbol
12	532 15 97-37	Decal Brake/Clutch Symbol Lt
14	532 15 97-36	Decal Chassis Hot Muffler

KEY NO.	PART NO.	DESCRIPTION
17	532 14 08-37	Decal Saddle Brake Parking
20	532 16 69-60	Decal Bypass Fender CRD
21	532 16 62-86	Decal Hex Belt Sch
—	532 13 83-11	Decal Lift Handle
—	532 18 10-90	Pad Footrest RH
—	532 18 10-91	Pad Footrest LH
—	532 18 26-21	Decal Bagger Frame
—	532 18 24-51	Manual Operator's (CZ)
—	532 18 21-74	Manual Operator's (Euro)
—	532 18 21-70	Manual Parts

WHEELS & TIRES

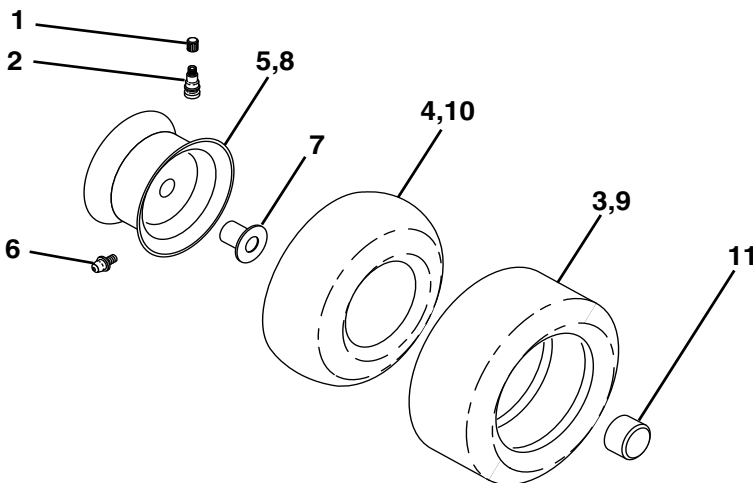

KEY NO.	PART NO.	DESCRIPTION
1	532 05 91-92	Cap Value Tire
2	532 06 51-39	Stem Value
3	532 10 62-22	Tire F Ts 15 X 6 0 - 6 Service
4	532 05 99-04	Tube Inner Front #35060
5	532 12 51-21	Rim Asm 6" front Service
6	532 12 49-57	Fitting Grease
7	532 12 49-59	Bearing Flange
8	532 12 51-22	Rim Asm 8" rear Service
9	532 13 84-68	Tire R Ts 20 x 8-8 Service
10	532 12 49-26	Tube Rear 9 5 X 8 Service
11	532 17 50-39	Cap Axle Blk 1 50 X 1 00
--	144334	Sealant, Tire (10 oz. tube)

NOTE: All component dimensions given in U.S. inches
1 inch = 25.4 mm

REPAIR PARTS

TRACTOR- -MODEL NO. 165H107RB (BA165H107RBA), PRODUCT 964 77 48-00
ENGINE

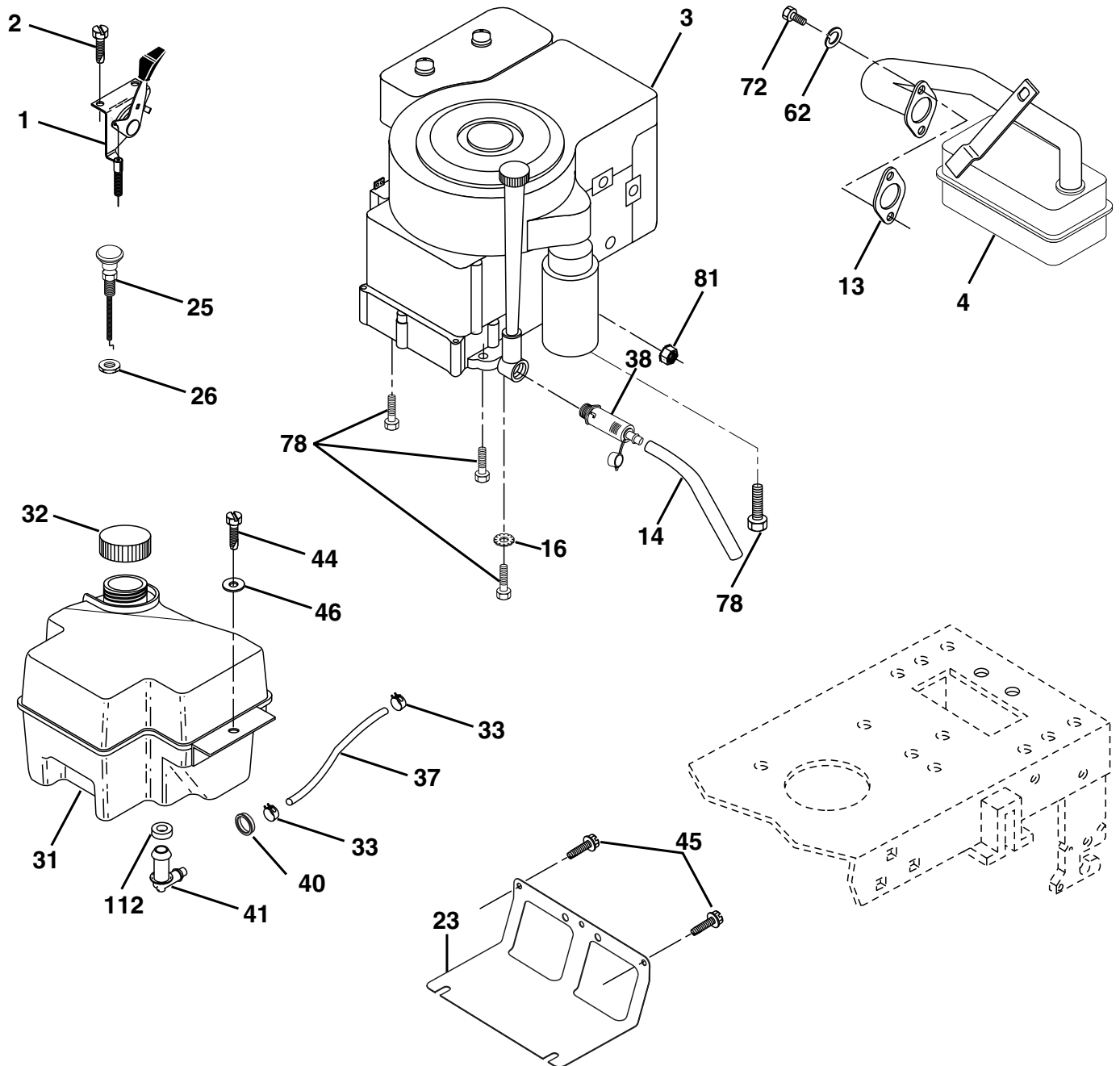

29

OPTIONAL EQUIPMENT
Spark Arrester

REPAIR PARTS

TRACTOR- -MODEL NO. 165H107RB (BA165H107RBA), PRODUCT 964 77 48-00
ENGINE

KEY NO.	PART NO.	DESCRIPTION
1	532 17 05-51	Control Throt/Ck
2	817 72 04-08	Screw Hex Thd Cut 1/4-20 x 1/2
3	-----	Engine B&S Model 31G777 (Order parts from engine manufacturer)
4	532 13 73-52	Muffler
13	532 16 52-91	Gasket Muffler
14	532 14 84-56	Tube Drain Oil Easy
16	811 05 06-00	Washer Lock Ext Tooth 3/8
23	532 16 98-37	Shield Brn/Dbr Guard
25	532 18 09-45	Control Choke
26	873 92 06-00	Nut Keps 3/8-24 Unf
29	532 13 71-80	Kit Spark Arrestor (Flat Scrn)
31	532 18 06-45	Tank Fuel 2.00
32	532 14 05-27	Cap Asm Fuel W/sym Vented
33	532 12 34-87	Clamp Hose Blk
37	532 13 70-40	Line Fuel
38	532 14 83-15	Plug Drain Oil Easy
40	532 12 40-28	Bushing Snap
41	532 13 92-77	Stem Fuel Line
44	817 67 04-12	Screw Hexwsh thdrol 1/4-20 x 3/4
45	817 00 06-12	Screw Hexwsh Thdr 3/8-16 x 3/4
46	819 09 14-16	Washer 9/32 x 7/8 x 16 Ga.
62	810 04 05-00	Washer, Lock Hvy. Hlcl Spr 5/16
72	871 07 05-12	Screw Hex Hd Cap 5/16-18 x 3/4
78	817 06 06-20	Screw 3/8-16 x 1/4
81	873 51 04-00	Nut Keps Hex 1/4-20 Unc
112	532 12 49-52	Bushing

NOTE: All component dimensions given in U.S. inches
1 inch = 25.4 mm

REPAIR PARTS

TRACTOR- -MODEL NO. 165H107RB (BA165H107RBA), PRODUCT 964 77 48-00
MOWER LIFT

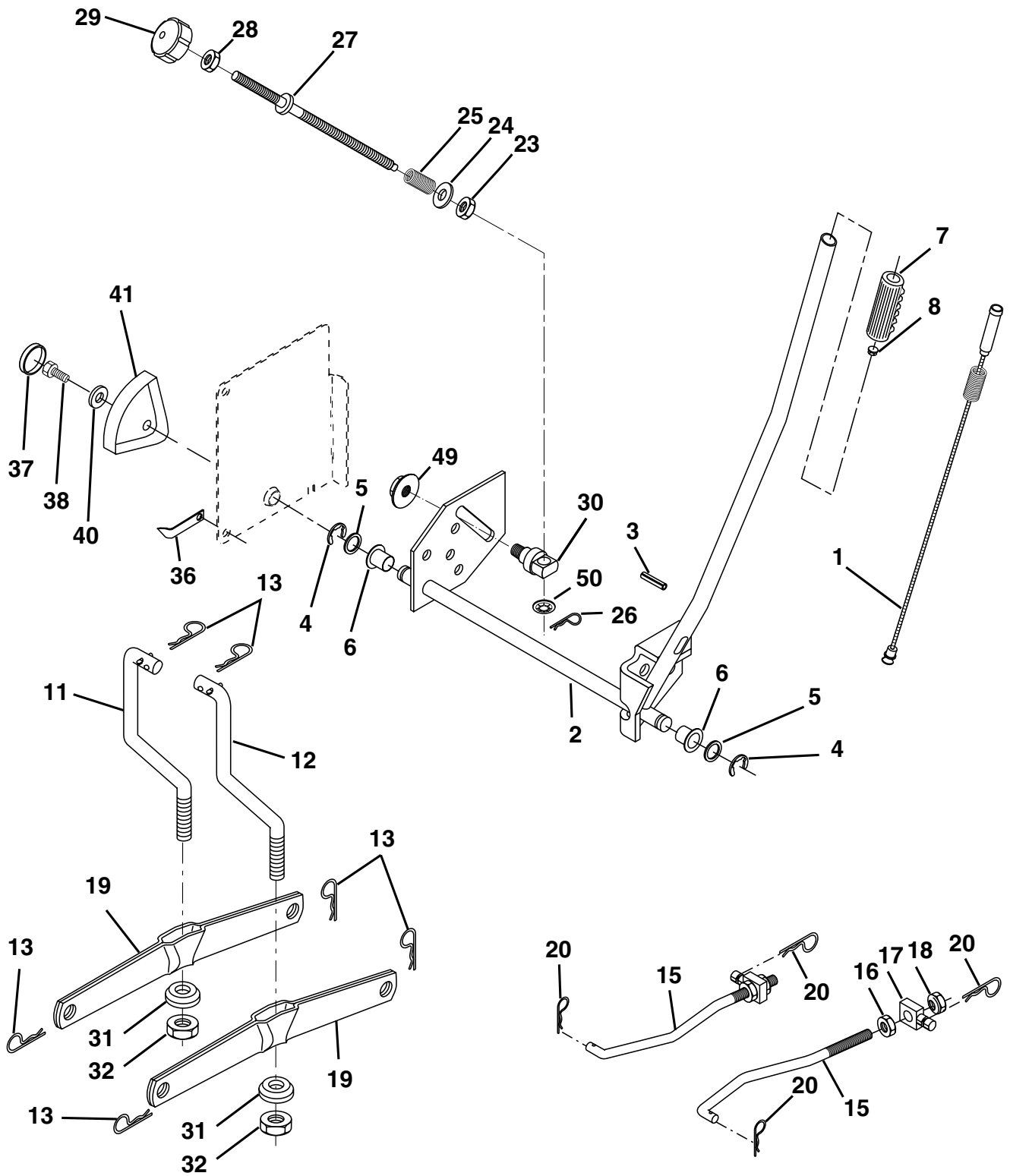

REPAIR PARTS

TRACTOR- -MODEL NO. 165H107RB (BA165H107RBA), PRODUCT 964 77 48-00
MOWER LIFT

KEY NO.	PART NO.	DESCRIPTION
1	532 15 94-60	Washer Asm Inner Spring W/Plunger
2	532 15 94-71	Shaft Asm. Lift
3	532 10 57-67	Pin Groove
4	812 00 00-02	E Ring #5133-62
5	819 21 16-21	Washer 21/32 x 1 x 21 Ga.
6	532 12 01-83	Bearing Nylon
7	532 12 56-31	Grip Handle Fluted
8	532 12 45-26	Button Plunger Black
11	532 16 58-29	Link Asm Lift L.H.
12	532 16 58-31	Link Asm Lift R.H.
13	532 12 46-70	Retainer Spring
15	532 17 32-88	Link Front
16	873 35 08-00	Nut Jam Hex 1/2-13 Unc
17	532 17 56-89	Trunnion Blk Zinc
18	873 80 08-00	Nut Lock w/wsh 1/2-13 Unc
19	532 13 98-68	Arm Suspension Mower
20	532 16 35-52	Retainer Spring
23	532 11 08-07	Nut Special
24	819 13 10-16	Washer 13/32 x 5/8 x 16 Ga.
25	532 12 48-74	Spring 2-1/8"
26	532 16 94-84	Retainer Clip
27	532 12 69-71	Rod Adj Lift Zinc 7.49 Wrk Lg
28	873 35 06-00	Nut Hex Jam 3/8-16 Unc
29	532 13 80-57	Knob Inf 3/8-16 Unc Blk w/sym
30	532 15 02-33	Trunnion Infin Height
31	532 16 98-65	Bearing, Pvt. Lift.
32	873 54 06-00	Nut Crownlock 3/8-24
36	532 15 50-97	Pointer Height Indicator
37	532 12 39-35	Plug Hole Blk 1.485/1.515 Dia
38	817 06 05-16	Screw 5/16-18 x 1
40	819 11 24-10	Washer 11/32 x 1-1/2 x 10 Ga.
41	532 12 39-34	Scale Ind Height Blk
49	532 14 52-12	Nut hex Flange Lock
50	532 11 04-52	Nut Push Phos & Oil

NOTE: All component dimensions given in U.S. inches
1 inch = 25.4 mm

REPAIR PARTS

**TRACTOR- -MODEL NO. 165H107RB (BA165H107RBA), PRODUCT 964 77 48-00
MOWER**

KEY NO.	PART NO.	DESCRIPTION	KEY NO.	PART NO.	DESCRIPTION
1	532 1691-60	Housing Asm. Mower 107 CRD	38	532 1698-51	Spacer Hub Arm Idler 107 CRD
2	872 1405-06	Bolt Rdhd Sqnk 5/16-18 Unc x 3/4	39	872 1106-22	Bolt Rdhd 3/8-16 Unc x 2-3/4 Gr. 5
3	532 1655-69	Bracket Asm. S-Bar Chass 92 CRD	40	873 6806-00	Nut Crownlock 3/8-16 Unc
4	532 1691-67	Bracket Bar Sway Deck 107 CRD	44	532 1755-38	Cover Mandrel Lh 107 CRD
5	532 1246-70	Retainer Spring	45	532 1755-39	Cover Mandrel Rh 107 CRD
6	532 1655-57	Bar Sway 92 CRD	46	532 1377-29	Screw Thd Roll 1/4-20 x 5/8
8	532 1817-12	Bolt 3/8-24 x 1.25 Gr8 Patched	55	532 1698-49	Arm Idler 107 CRD
9	810 0306-00	Washer Lock Hvy 3/8 Unplated	61	532 1751-59	Spring Tension Belt
10	532 1402-96	Washer Hard Blade Mower vented	68	532 1691-78	Hex-Belt 107 Mower
11	532 1805-83	Blade 3-1 Lh 107 CRD	69	532 1654-82	Shaft Asm W/Lwr Brg Rh Thd CRD
13	532 1376-45	Shaft Asm. W/Lower Bearing	84	532 1560-85	Keeper Belt Idler
14	532 1287-74	Housing Mandrel Vented (Machd)	116	532 1376-44	Bolt Shoulder
15	532 1104-85	Bearing Ball Mandrel	117	532 1339-57	Wheel Gage Donut Wide
16	532 1805-84	Blade 3-1 Rh 107 CRD	118	873 9306-00	Nut Centerlock 3/8-16 Unc
19	532 1328-27	Bolt Shoulder 5/16-18 Thd Form	119	819 1214-14	Washer 3/8 x 7/8 x 14 Ga.
20	532 1817-13	Bolt 3/8-24 x 1.25 Gr8 Ptch Lhthd	124	872 1106-12	Bolt Carr Sh 3/8-16 x 1-1/2 Gr5
21	873 6805-00	Nut Crown Lock 5/16-18	130	872 1105-06	Bolt Rdhdsqnk 5/16-18 Unc x 3/4
22	532 1691-65	Bracket Idler Sprt RR 107 CRD	131	532 1656-61	Chute Bagger CRD 92cm
23	532 1691-66	Bracket Idler Sprt RF 107 CRD	161	532 1804-24	Blade Cross LH 107
24	532 1691-70	Bracket Suspension LF 107 CRD	162	532 1808-78	Adapter Weldnut Blade 107
25	532 1691-71	Bracket Suspension RF 107 CRD	163	532 1804-25	Blade Cross Rh 107
26	532 1652-37	Brace Support Susp Frt CRD	-	532 1818-57	Mandrel Assembly (Includes Housing, Shaft and Shaft Hardware Only - Pulley Not Included)
27	532 1691-72	Bracket Asm. Susp RR 107 CRD	-	532 1818-58	Mandrel Asm CRD Lh Threads SVC
28	532 1691-68	Bracket Asm. Susp LR 107 CRD	-	532 1817-70	Replacement Mower Complete
30	532 1739-84	Screw Thd Rolling D.D. PT			
31	532 1299-63	Washer Spacer Mower Vented			
32	532 1757-07	Mandrel Pulleys			
33	532 1783-42	Nut Flg Top Lock			
34	532 1795-09	Bracket Gauge Wheel Lf 107 CRD			
35	532 1762-92	Bracket Gauge Wheel Rf 107 CRD			
36	532 1467-63	Pulley Idler V-Groove Dim 4.25			
37	819 1313-16	Washer 11/32 x 13/16 x 16 Ga			

NOTE: All component dimensions given in U.S. inches
1 inch = 25.4 mm

REPAIR PARTS

TRACTOR- -MODEL NO. 165H107RB (BA165H107RBA), PRODUCT 964 77 48-00
BAGGER

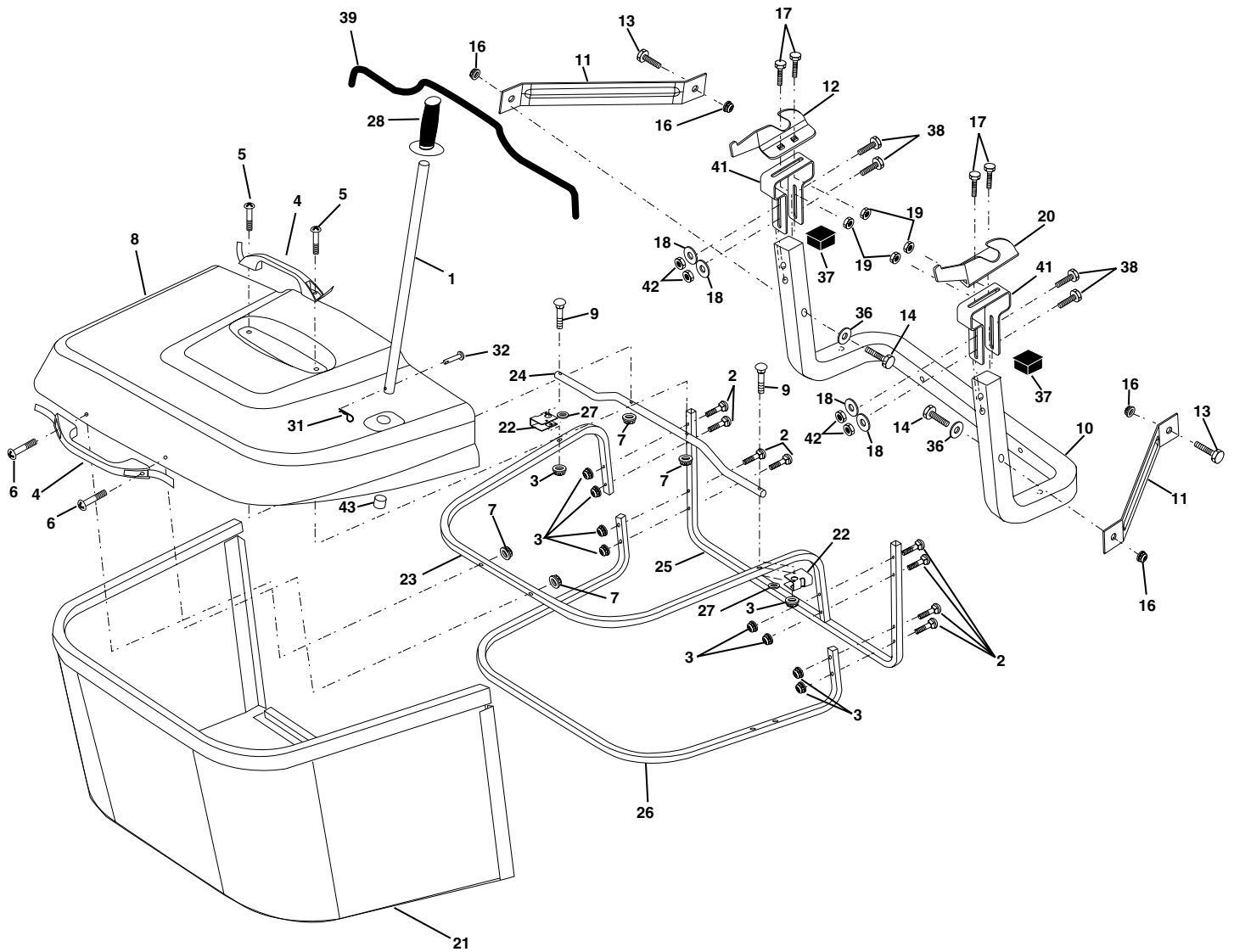

REPAIR PARTS

TRACTOR- -MODEL NO. 165H107RB (BA165H107RBA), PRODUCT 964 77 48-00
BAGGER

KEY NO.	PART NO.	DESCRIPTION
1	532 16 52-49	Tube Handle Bagger CRD
2	872 14 04-16	Bolt Carriage 1/4-20 X 2.0 Gr.5
3	532 12 39-76	Nut Lock 1/4 Lge Flg Gr. 5 Zinc
4	532 16 99-16	Handle Bagger w/Lvrs Gr. 5 Zinc
5	874 98 10-24	Screw Pan Head #10-24 X 1.50 Blk
6	874 98 10-32	Screw Pan Hd
7	873 40 10-00	Nut Wiz Lock Hex Serr/Hd #10-24
8	532 18 25-14	Cover Bagger
9	872 14 04-18	Bolt Carriage 1/4-20 x 2.25d x Gr.5
10	532 18 12-82	Tube Support Bagger CRD
11	532 16 57-19	Bracket Support Upper Bag CRD
12	532 16 96-85	Bracket Horiz. Adj Bagger
13	872 11 06-06	Bolt Rdhd Sht Sqnk 3/8-16 X 3/4
14	874 52 06-36	Bolt Hex 3/8-16 X 2-1/4 Gr. 5
16	873 90 06-00	Nut Lock Flg 3/8-16 Unc
17	872 14 05-06	Bolt Rdhd Sht Sqnk 5/16-18Unc X 3/4
18	819 11 12-16	Washer 11/32 x 3/4 x 16
19	873 90 05-00	Nut Lock Hex Flange 5/16-18
20	532 16 96-84	Bracket Horiz Adj Bagger
21	532 18 08-80	Bag Asm CRD
22	532 16 57-81	Bracket Side Bagger CRD
23	532 16 57-82	Tube Upper Bagger CRD
24	532 16 57-83	Tube Pivot Bagger CRD
25	532 18 01-24	Tube Front Bagger CRD
26	532 16 57-85	Tube Lower Bagger CRD
27	532 16 96-92	Bushing Snap Bagger CRD
28	532 16 57-87	Grip Handle Black
31	532 12 47-88	Retainer Spring 1" Zinc/Cad
32	532 12 68-75	Rivet Rd Hd Drilled 3/8 Dia
36	819 13 20-16	Washer 13/32 x 1-1/4 x 16 Ga.
37	532 17 54-01	Plug Support Bagger CRD
38	872 01 05-20	Bolt 5/16-18 x 2-1/2
39	532 18 09-85	Seal
41	532 16 96-83	Bracket Vert Adj Bagger CRD
42	873 80 05-00	Nut Lock Hex W/Ins 5/16-18 UNC
43	532 17 40-83	Plug Tubing end

NOTE: All component dimensions given in U.S. inches
1 inch = 25.4 mm

SERVICE NOTES

SERVICE NOTES

Electrolux Outdoor Products Service Contacts

BELGIQUE/BELGIË

Electrolux Outdoor Products
Tel: 02 363 0311, Fax: 02 363 0391

CESKÁ REPUBLIKA

Electrolux, spol. s.r.o., oz Electrolux Outdoor Products,
Dobronická 635, 148 25 Praha 4
Tel: 02/6111 2408-9, Info-linka: 0800/110 220
Internet: www.partner-flymo.cz E-mail: info@husqvarna.cz

DANMARK

Electrolux Outdoor Products, Flymo/Partner A/S,
Lundtoftegrdsvej 93A, DK 2800 Kgs.Lyngby
Tel: 45 8775777, www.flymo-partner.dk

DEUTSCHLAND

Electrolux Outdoor Products
Tel: 097 21 7640, Fax:097 21 764202

ESTONIA

Electrolux Estonia Ltd (Electrolux Eesti AS)
Tel: (372) 6650010

FRANCE

Electrolux Outdoor Products
Tel 01 46 67 8141, Fax 01 43 34 2491

FINLAND SUOMI

Electrolux Outdoor Products Finland
Tel: 00 39611, Fax: 00 39 612632

ITALIA

McCulloch Italiana s.r.l. - Via Como 72, 23868 Valmadrera
(LECCO) - ITALIA, Tel: 800 017829, Fax: 0341 581671

IRELAND

Electrolux Outdoor Products
Tel: 01 4565222, Fax: 01 4568551

MAGYARORSZÁG

Electrolux Lehel Kft
Tel: 00 36 1 251 41 47

NORGE

Electrolux Outdoor Products
Tel: 69 10 47 90

NEDERLAND

Electrolux Outdoor Products BV
Tel: 0172-468322, Fax: 0172-468219

ÖSTERREICH

HUSQVARNA Zentralwerksttte, Industriezeile 36, 4020 LINZ,
Tel: 0732 770101-60, Fax: 0732 795922

POLSKA

Electrolux Poland Sp. z.o.o. Husqvarna, 01-612 Warszawa
Myslowicka 10/2
Tel:- (22) 8332949

SLOVENIJA

SKANTEH d.o.o.
Tel:- (061) 133 70 68, Fax:-(061) 133 70 68

SLOVENSKA

Electrolux Slovakia s.r.o., Borova Sihat 211, 033 01 Lipt. Hradok
Tel: 044 522 14 19, Fax: 044 522 14 18, www.flymo-partner.sk

SCHWEIZ/SUISSE/SUIZZERA

Electrolux Outdoor Products
Tel 062 889 93 50 / 889 94 25, Fax 062 889 93 60 / 889 94 35

SVERIGE

Electrolux Outdoor Products, Sverige
Tel: 036 ù 14 67 00, Fax: 036 ù 14 60 70

UNITED KINGDOM

Electrolux Outdoor Products, United Kingdom
Tel: 01325 300303, Fax: 01325 310339