

REPAIR PARTS MANUAL
MODEL NO. BA14592RBB
Lawn Tractor

 McCULLOCH®

HOW TO USE THIS MANUAL

This manual is designed to provide the customer with a means to identify the parts on his/her tractor when ordering repair parts. The illustrations may or may not represent the actual assemblies; therefore, it is not recommended to use this manual as a guide to assemble or disassemble the tractor. Some hardware and parts are drawn larger in order to more readily identify them.

Each tractor has its own model number.

The model number for your tractor can be found on the fender under the seat.

When ordering parts, always give the following information:

- Product - "Tractor"
- Model Number - "BA14592RBB"
- Part Number
- Part Description

TABLE OF CONTENTS

SCHEMATIC	3
ELECTRICAL.....	4-5
CHASSIS.....	6-7
DRIVE.....	8-9
STEERING	10-11
SEAT	12
DECALS.....	13
ENGINE.....	14-15
MOWER LIFT	16-17
MOWER DECK	18-19
BAGGER	20-21

TRACTOR - - MODEL NO. BA14592RBB, PRODUCT NO. 964 77 47-00

SCHEMATIC

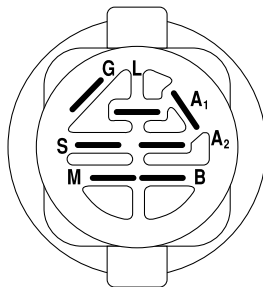
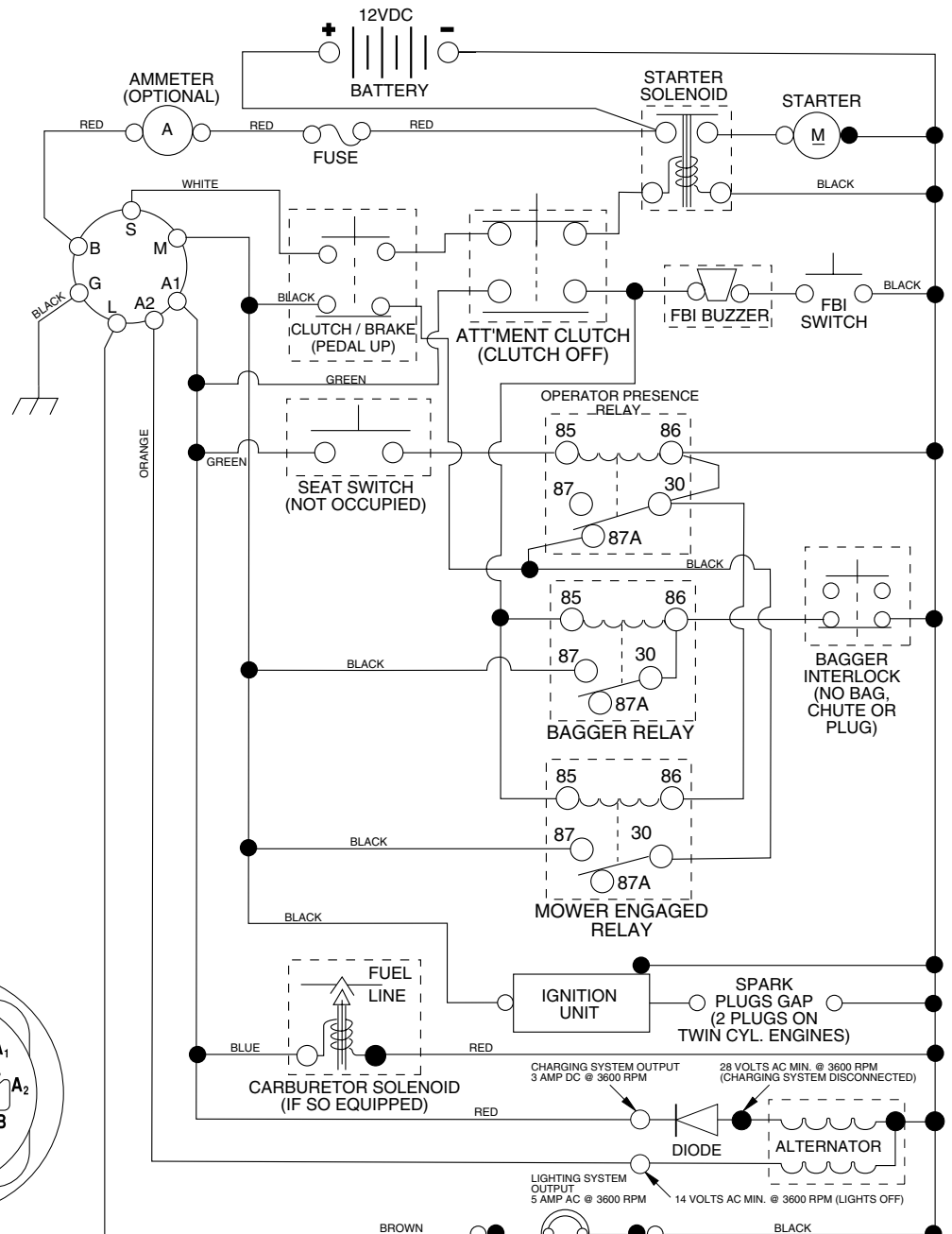

IGNITION SWITCH

POSITION	CIRCUIT	"MAKE"
OFF	M+G+A1	NONE
RUN/LIGHT	B+A1	A2+L
RUN	B+A1	NONE
START	B + S + A1	NONE

WIRING INSULATED CLIPS
 NOTE: IF WIRING INSULATED CLIPS WERE REMOVED FOR SERVICING OF UNIT, THEY SHOULD BE REPLACED TO PROPERLY SECURE YOUR WIRING.



PTO SWITCH

POSITION	CIRCUIT
OFF	C + G, B + H
ON	C + F, B + E, A + D

HEADLIGHTS

NOTE
 YOUR TRACTOR IS EQUIPPED WITH A SPECIAL ALTERNATOR SYSTEM. THE LIGHTS ARE NOT CONNECTED TO THE BATTERY, BUT HAVE THEIR OWN ELECTRICAL SOURCE. BECAUSE OF THIS, THE BRIGHTNESS OF THE LIGHTS WILL CHANGE WITH ENGINE SPEED. AT IDLE THE LIGHTS WILL DIM. AS THE ENGINE IS SPEEDED UP, THE LIGHTS WILL BECOME THEIR BRIGHTEST.

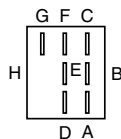

REPAIR PARTS

TRACTOR - - MODEL NO. BA14592RBB, PRODUCT NO. 964 77 47-00
ELECTRICAL

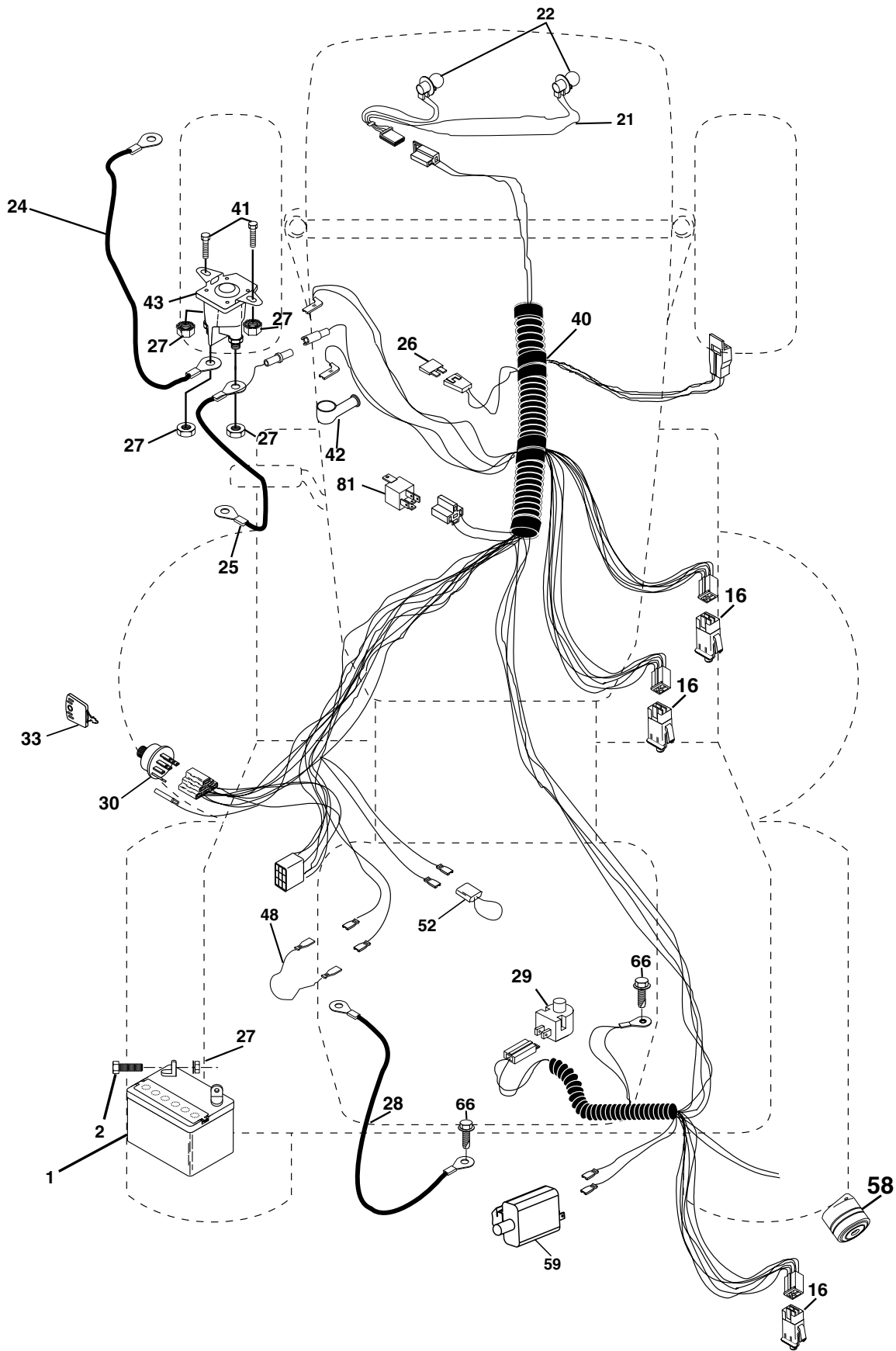

REPAIR PARTS

TRACTOR - - MODEL NO. BA14592RBB, PRODUCT NO. 964 77 47-00
ELECTRICAL

KEY NO.	PART NO.	DESCRIPTION
1	532 16 34-65	Battery
2	874 76 04-12	Bolt Hex Hd 1/4-20 Unc X 3/4
16	532 17 61-38	Switch Interlock Push-In
21	532 17 56-85	Harness Asm. Light
22	532 00 41-52	Bulb Light #1156
24	532 12 47-80	Cable Starter 6Ga 11" Red
25	532 16 59-87	Cable Battery Crd 56" Red
26	532 17 51-58	Fuse 20 Amp
27	873 51 04-00	Nut Keps Hex 1/4-20 Unc
28	532 12 77-25	Cable Ground 6 Ga 18" Black
29	532 16 07-84	Switch Plunger Normal Op Olive
30	532 17 55-66	Switch Ignition
33	532 14 04-01	Key Ign
40	532 17 97-28	Harness Ign
41	871 11 04-08	Bolt Flk Fin Hex 1/4-20 Unc X 1/2
42	532 13 15-63	Cover Terminal Red
43	532 17 88-61	Solenoid
48	532 14 08-44	Adapter Ammeter Rectangular
52	532 14 19-40	Protection Wire Loop
58	532 16 94-19	Buzzer Crd
59	532 18 03-79	Switch FBI CRD
66	817 49 06-08	Screw Thdrol 3/8-16 x 1/2 Ty-Tt
81	532 10 97-48	Relay Asm

NOTE: All component dimensions given in U.S. inches.
1 inch = 25.4 mm.

REPAIR PARTS

TRACTOR - - MODEL NO. BA14592RBB, PRODUCT NO. 964 77 47-00
CHASSIS AND ENCLOSURES

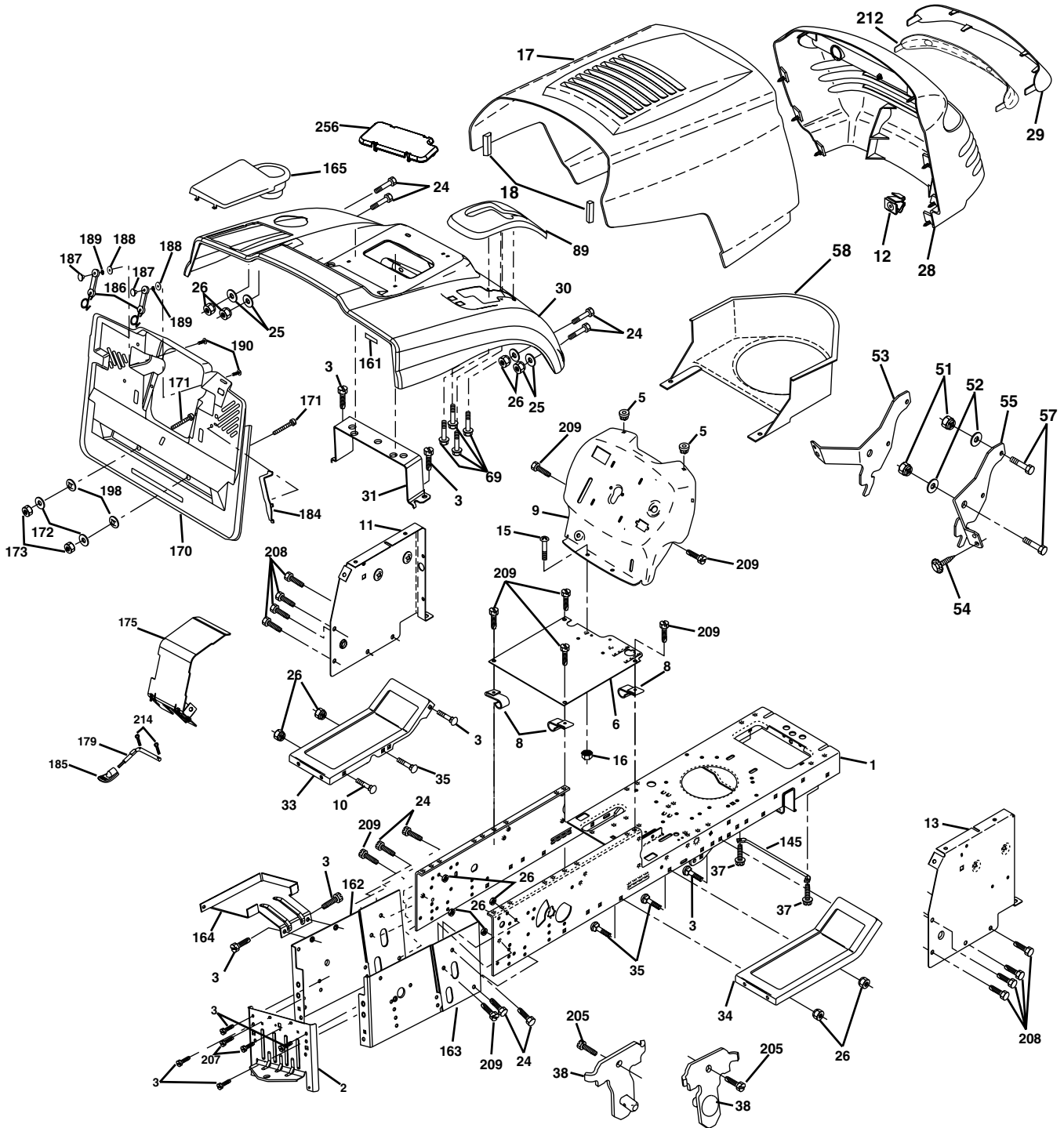

REPAIR PARTS

TRACTOR - - MODEL NO. BA14592RBB, PRODUCT NO. 964 77 47-00 CHASSIS AND ENCLOSURES

KEY NO.	PART NO.	DESCRIPTION
1	532 17 46-20	Chassis
2	532 18 03-84	Drawbar
3	817 06 06-12	Screw 3/8-16 x .75
5	532 15 52-72	Bumper Hood/Dash
6	532 15 59-23	Saddle
8	532 12 64-71	Clip Insulator 13/32 Mtg. Hole
9	532 17 22-43	Dash
10	872 14 06-08	Bolt, Carriage 3/8-16 x 3/4
11	532 17 49-96	Panel, Dash, L.H.
12	532 14 56-60	Clip Tinnerman Grille P/L
13	532 18 17-19	Panel, Asm. Dash R.H.
15	874 18 05-12	Screw, Machine, Truss Head 5/16-18 UNC x 3/4
16	873 51 05-00	Nut
17	532 18 25-05	Hood Assembly
18	532 12 69-38	Bumper Hood
24	874 78 06-16	Bolt
25	819 13 13-12	Washer 13/32 x 13/16 x 12 Gauge
26	873 80 06-00	Nut
28	532 17 91-01	Grille Lens Asm
29	532 16 81-54	Lens
30	532 18 25-06	Fender
31	532 16 51-56	Bracket, Fender Support
33	532 18 25-07	Footrest, L.H.
34	532 18 25-08	Footrest, R.H.
35	872 11 06-06	Bolt
37	817 49 05-08	Screw Thdrol 5/16-18 x 1/2 TYT
38	532 18 17-48	Bracket Asm Pivot Mower Rear
51	873 80 04-00	Nut Lock w/Insert 1/4-20 UNC
52	819 09 14-16	Washer 9/32 x 7/8 x 16 Ga.
53	532 14 46-97	Bracket Grille Lh
54	532 16 14-64	Screw Hex Wshd 8-18 x 7/8
55	532 14 46-96	Bracket Grille Rh
57	874 78 04-12	Bolt, Fin Hex 1/4-20 UNC x .75

KEY NO.	PART NO.	DESCRIPTION
58	532 15 01-27	Duct Air Engine Pl/Lt
69	532 14 24-32	Screw Hex 1/4-1/2
89	532 18 13-88	Console
145	532 15 65-24	Rod Pivot Chassis/Hood
162	532 18 03-82	Bracket Exten Chassis Lh CRD
163	532 18 03-83	Bracket Exten Chassis Rh CRD
164	532 16 56-05	Support Battery CRD
165	532 18 13-56	Cover Battery CRD Lt
170	532 17 88-62	Backplate CRD
171	872 14 06-20	Bolt Rdhd Sqnk 3/8-16 x 2-1/2 G5
172	819 13 20-16	Washer 13/32 x 1-1/4 x 16 Ga.
173	873 51 06-00	Nut, Keps Hex 3/8-16 UNC
175	532 18 03-10	Trap Door CRD
179	532 18 03-76	Rod Pivot FBI CRD
184	532 17 46-62	Bracket Actuator Bagger CRD
185	532 18 11-01	Knob Rod
186	532 16 07-93	Latch Asm Multch Bagger
187	532 12 50-04	Nut Weld .327/.304 #10-24
188	819 06 12-16	Washer #10
189	810 07 10-00	Washer Lock #10
190	871 08 10-10	Screw Pan Hd Phillips 10-24 x 5/8
198	532 16 89-37	Nut Push
205	817 49 06-08	Screw 3/8-16 x 1/2
208	817 67 06-08	Screw Thdrol 3/8-16 x 1/2
209	817 00 06-12	Screw Hex Wsh Thdrol 3/8-16 x 3/4
212	532 15 62-29	Insert Lens Reflective
214	532 12 47-88	Retainer Spring 1"
215	817 06 05-08	Screw 5/16-18 x 1/2
256	532 18 13-61	Cover Fender Rack CRD
--	532 00 54-79	Plug, Button

NOTE: All component dimensions given in U.S. inches.
1 inch = 25.4 mm.

REPAIR PARTS

TRACTOR - - MODEL NO. BA14592RBB, PRODUCT NO. 964 77 47-00
DRIVE

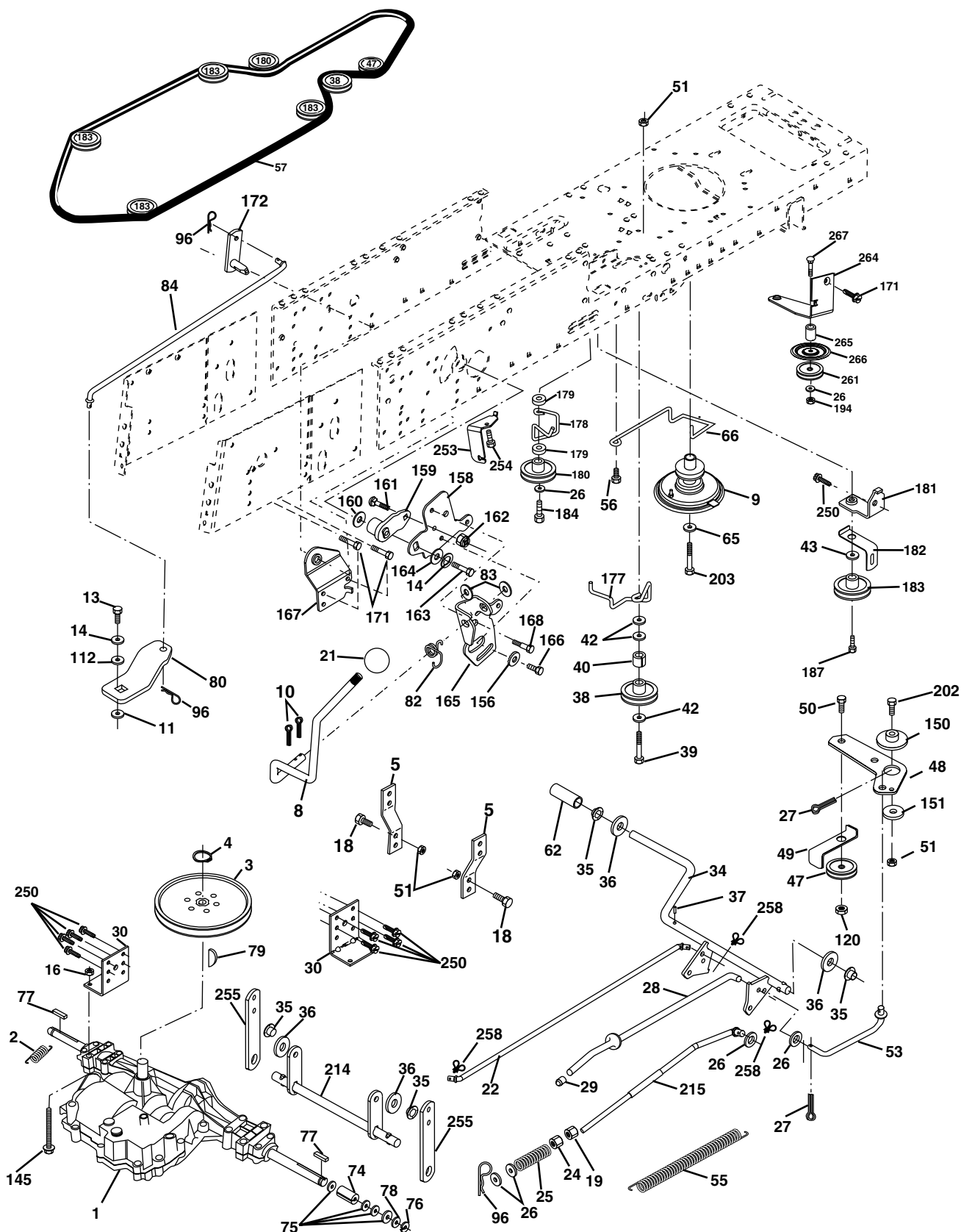

REPAIR PARTS

TRACTOR - - MODEL NO. BA14592RBB, PRODUCT NO. 964 77 47-00

DRIVE

KEY NO.	PART NO.	DESCRIPTION	KEY NO.	PART NO.	DESCRIPTION
1	-----	Transaxle Peerless 206-546 Order parts from transaxle manufacturer	80	532 14 50-90	Arm Shift PMST 20" Tires
2	532 14 66-82	Spring Brake Return	82	532 16 57-11	Spring, Torsion
3	532 16 59-99	Pulley Transaxle	83	819 17 12-16	Washer 17/32 x 3/4 x 16 Ga.
4	812 00 00-28	Ring Retainer #5100-62	84	532 16 56-21	Link Shift CRD Pmst 18" Tires
5	532 12 15-20	Strap torque 30 degrees	96	532 12 47-88	Spring, Retainer 1"
8	532 16 56-19	Rod Shift Fender Adjust Lt	112	819 09 12-10	Washer 9/32 x 3/4 x 10 Ga.
9	532 18 03-54	Clutch Noram	120	873 90 06-00	Nut Lock 3/8-16
10	876 02 04-16	Pin, Cotter 1/8 x 1	145	874 49 05-40	Bolt Hex FGHD 5/16-18 x Gr 5
11	532 10 57-01	Washer Plate Shf .3888 sq hole	150	532 16 58-50	Bushing, Bellcrank Grnd Dr
13	874 55 04-12	Bolt 1/4-28 Unf Gr 8 w/patch	151	819 13 32-10	Washer 13/32 x 2 x 10 Ga.
14	810 04 04-00	Washer, Lock Hvy Helical	156	532 16 60-02	Washer Srred 5/16 ID x 1.125
16	873 80 05-00	Nut, Lock Hex w/Ins 5/16-18 UNC	158	532 16 55-89	Bracket Shift Mount
18	874 78 06-16	Bolt Hex 3/8-16 UNC x 1 Gr.5	159	532 16 54-94	Hub Tapered Flange Shift Lt
19	873 80 06-00	Nut, Lock Hex w/Wsh 3/8-16 UNC	160	819 29 20-16	Washer 29/32 x 1-1/4 x 16 Ga
21	532 10 69-33	Knob Round 1/2-13 Unc Blk	161	872 14 04-06	Bolt Rdhd Sqnk 1/4-20 x 3/4 Gr 5
22	532 17 56-07	Rod, Brake CRD Main	162	873 68 04-00	Nut Crownlock 1/4-20 Unc
24	873 35 06-00	Nut	163	874 78 04-16	Bolt Hex Fin 1/4-20 Unc x 1 Gr 5
25	532 10 68-88	Spring, Rod, Brake	164	819 09 10-10	Washer 5/8 x .281 x 10 Ga.
26	819 13 13-16	Washer 13/32 x 13/16 x 16 Ga.	165	532 16 56-23	Bracket Pivot Lever
27	876 02 04-12	Pin, Cotter 1/8 x 3/4	166	532 16 68-80	Screw 5/16-18 x 5/8
28	532 17 57-65	Rod, Parking Brake	167	532 16 55-88	Bracket Support Shift CRD
29	532 07 16-73	Cap, Parking Brake	168	532 16 54-92	Bolt Shoulder 5/16-18 x .561
30	532 17 49-73	Bracket, Mfg. Transaxle	171	817 49 06-08	Screw Thdrol 3/8-16 x 1/2 Ty-Tt
34	532 17 55-78	Shaft, Asm Pedal Foot CRD	172	532 16 56-35	Shaft Asm Shift Front CRD PMST
35	532 12 01-83	Bearing, Nylon	177	532 16 59-32	Keeper Flat Idler 3.06" CRD
36	819 21 16-16	Washer 21/32 x 1 x 16 Ga.	178	532 16 59-33	Keeper Belt Idler 1.88" CRD
37	532 12 49-63	Pin, Roll 3/16 x 1"	179	532 12 09-58	Washer Sintered
38	532 16 59-36	Pulley, Flat	180	532 16 56-30	Pulley Flat Composite 3.06"
39	874 76 06-44	Bolt Fin Hex 3/8-16 Unc x 2-3/4	181	532 18 02-11	Bracket Idler Ground Drive CRD
40	532 12 49-65	Spacer, Split 395 x 59 Bzp	182	532 16 56-34	Keeper Belt 2.5" Od V-Idler CRD
42	819 13 13-12	Washer 13/32 x 13/16 x 12 Ga.	183	532 17 90-50	Pulley V-Idler 2.50" Od CRD
47	532 12 77-83	Pulley, Idler, V Groove Plasitc	184	817 49 06-44	Screw Hexwsh Thdrol 3/8-16 x 2-3/4
48	532 15 44-07	Bellcrank Clutch Grnd Drv	187	817 58 05-20	Screw 5/16-18 x 1.25
49	532 12 32-05	Retainer, Belt Style Spring	202	872 11 06-14	Bolt Carr. SH 3/8-16 x 1-3/4 Gr. 5
50	874 76 06-24	Bolt Hex Hd 3/8-16 UNC x 1-1/2	203	871 17 07-80	Bolt Hex 7/16-20 x 5
51	873 68 06-00	Nut, Crownlock 3/8-16 UNC	214	532 17 56-09	Shaft Asm. Brake
53	532 10 57-10	Link, Clutch 7.66	215	532 17 56-51	Rod Brake Secondary
55	532 10 57-09	Spring, Return, Clutch	250	817 06 06-12	Screw 3/8-16 x .75
56	874 76 06-20	Bolt, Hex 3/8-16 UNC x 1-1/4	253	532 17 50-28	Bracket Cable Chassis
57	532 16 56-31	V-Belt Kev PMST CRD	254	817 06 06-16	Screw 3/8-16 x 1.0
62	532 12 48-72	Cover, Pedal	255	532 17 56-08	Brace Shaft Brake
65	810 04 07-00	Washer	258	532 17 80-62	Clip Retainer
66	532 15 47-78	Keeper, Belt Engine F-Proof	261	532 17 34-38	Pulley Idler Flat
74	532 13 70-57	Spacer Axle	263	817 00 06-12	Screw Hxwsh Thdr 3/8-16 x 3/4
75	532 12 17-49	Washer 25/32 x 1-1/4 x 16 Ga.	264	532 18 19-95	Bracket Clutch Mtg.
76	812 00 00-01	Ring, E	265	532 18 20-13	Spacer Idler Chassis
77	532 12 35-83	Key, Square	266	532 18 20-61	Shield Idler
78	532 12 17-48	Washer 25/32 x 1-5/8 x 16 Ga.	267	872 14 06-24	Bolt Rdhd Sqnk 3/8-16 x 3
79	532 12 50-96	Key Woodruff			

NOTE: All component dimensions given in U.S. inches
1 inch = 25.4 mm

REPAIR PARTS

TRACTOR - - MODEL NO. BA14592RBB, PRODUCT NO. 964 77 47-00
STEERING ASSEMBLY

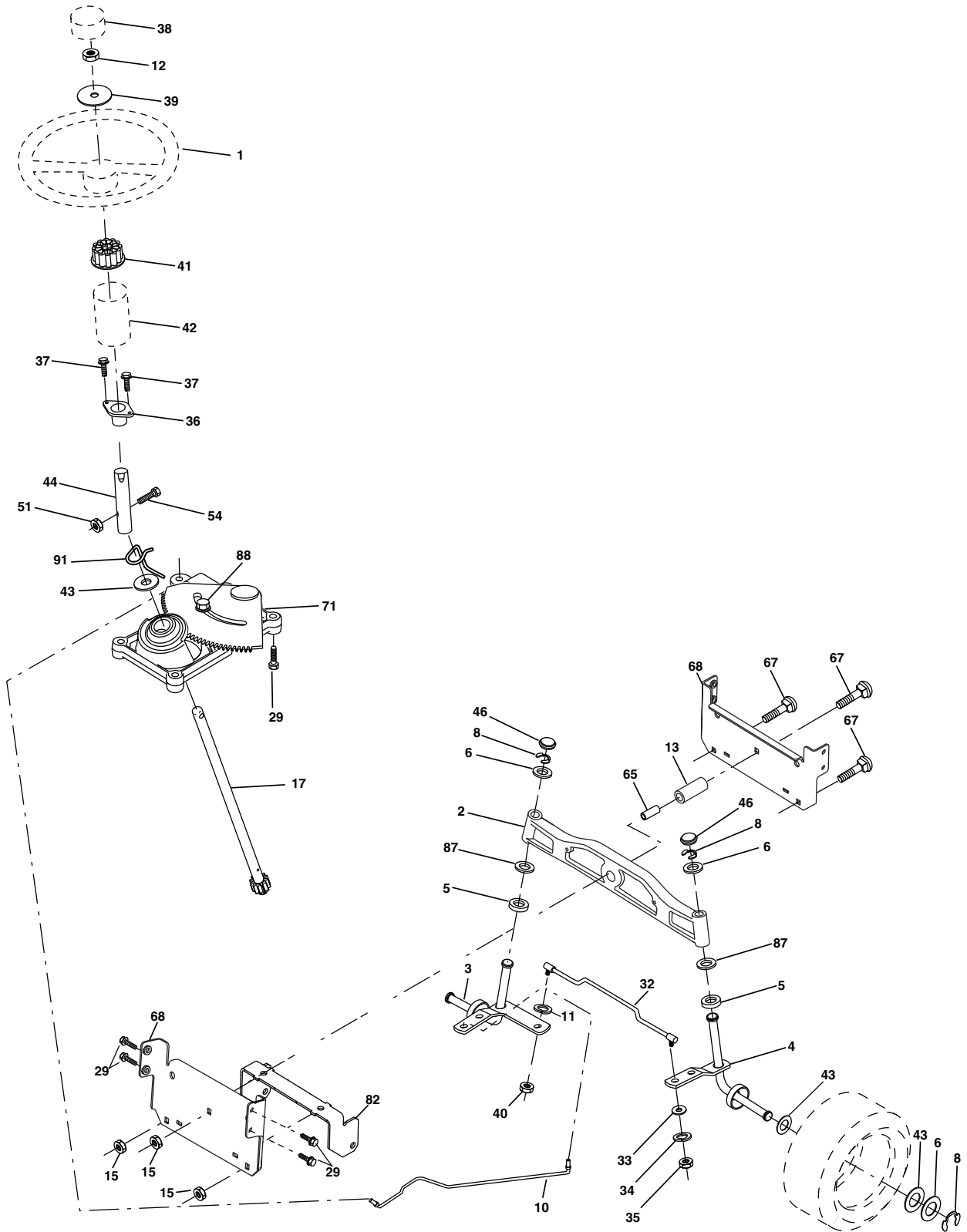

REPAIR PARTS

TRACTOR - - MODEL NO. BA14592RBB, PRODUCT NO. 964 77 47-00 STEERING ASSEMBLY

KEY NO.	PART NO.	DESCRIPTION
1	532 17 59-04	Steering Wheel
2	532 17 23-93	Cast Iron Axle Assembly
3	532 16 98-40	Spindle Assembly, L.H.
4	532 16 98-39	Spindle Assembly, R.H.
5	532 12 49-31	Bearing, Race, Thrust, Hardened
6	532 12 17-48	Washer 25/32 x 1-5/8 x 16 Gauge
8	812 00 00-29	Ring, Klip
10	532 17 51-21	Link, Drag
11	810 04 06-00	Washer, Lock
12	873 94 08-00	Nut Hex Jam Toplock 1/2-20 Unf
13	532 13 65-18	Spacer Brg Axle Front
15	532 14 52-12	Nut, Hexflange Lock
17	532 18 06-41	Shaft Assembly, Steering
29	817 06 06-12	Screw, 3/8-16 x 3/4
32	532 17 01-62	Rod, Tie
33	819 11 12-16	Washer 11/32 x 3/4 x 16 Ga
34	810 04 05-00	Washer Lock Hvy Hlcl Spr 5/16
35	873 54 05-00	Nut Crownlock 5/16-24 Unf
36	532 15 50-99	Bushing, Steering
37	532 15 29-27	Screw TT #10-32 x 5 x 3/8 Flange
38	532 17 59-05	Cap Wheel Steer
39	819 18 38-12	Washer 9/16 x 2-3/8
40	532 12 47-01	Nut Lock Center 3/8-24 Unf
41	532 10 07-11	Adaptor, Steering Wheel
42	532 16 96-33	Boot, Steering Dash P/L Mtl
43	532 12 17-49	Washer 25/32 x 1-1/4 x 16 Gauge
44	532 18 06-40	Extension Steering
46	532 12 12-32	Cap, Spindle
51	873 54 04-00	Nut Crownlock 1/4-28
54	871 13 04-20	Bolt Hex 1/4-28 Unf x 1-1/4 Gr. 8
65	532 16 03-67	Spacer Brace Axle
67	872 14 06-18	Bolt Rdhd Sq 3/8-16 UNC x 2-1/4
71	532 17 51-46	Steering Asm.
68	532 16 98-27	Brace Axle
82	532 16 98-35	Bracket Susp Chassis Front
87	532 17 39-66	Washer Flat .781 x 1-1/2 x .14
88	532 17 51-18	Bolt Shoulder 7/16-20 Unc
91	532 17 55-53	Clip Steering

NOTE: All component dimensions given in U.S. inches.
1 inch = 25.4 mm.

REPAIR PARTS

TRACTOR - - MODEL NO. BA14592RBB, PRODUCT NO. 964 77 47-00
SEAT ASSEMBLY

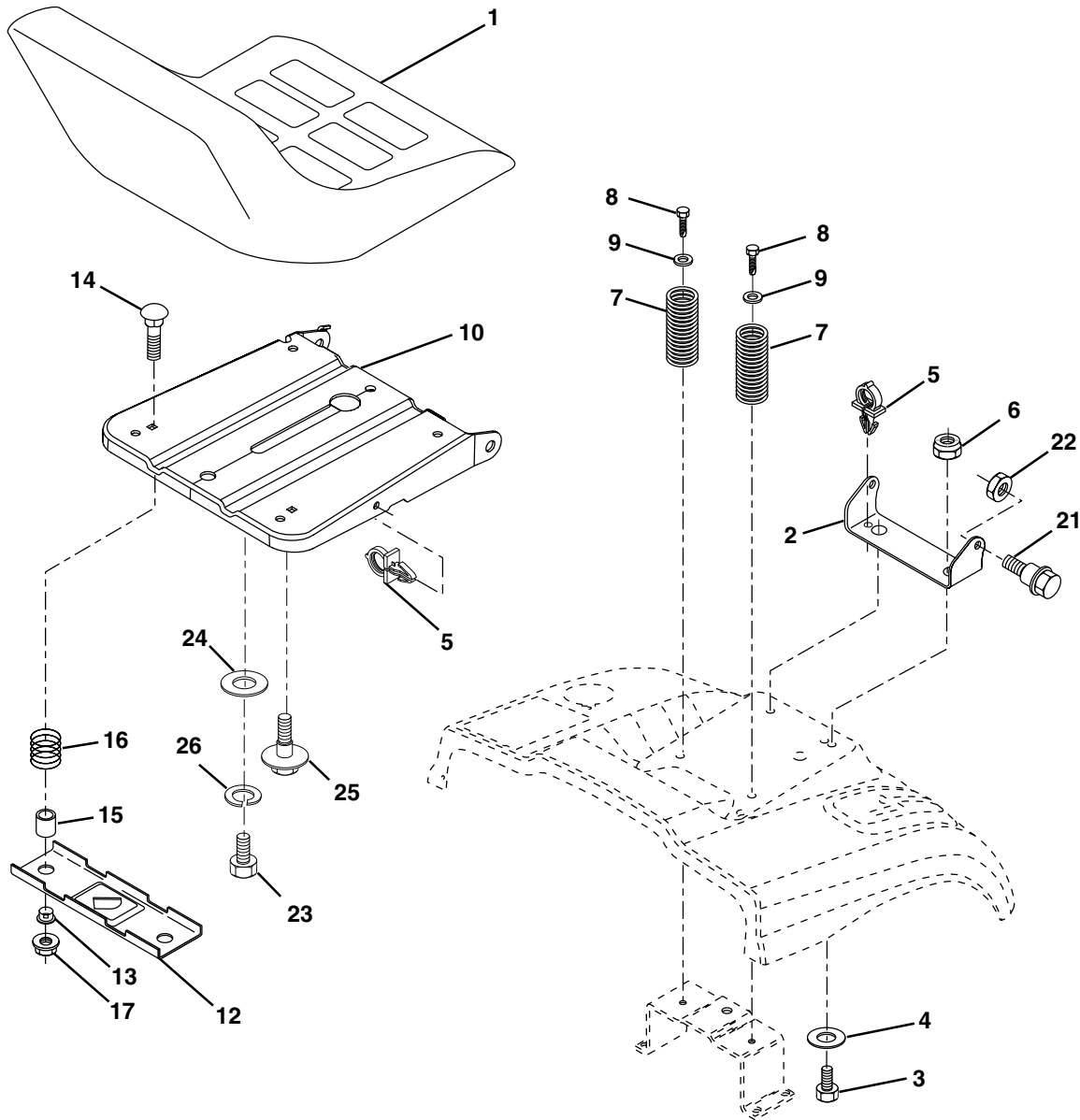

KEY NO.	PART NO.	DESCRIPTION
1	532 14 01-16	Seat
2	532 14 05-51	Bracket Pnt Pivot Seat (blk)
3	871 11 06-16	Bolt Fin Hex 3/8-16 Unc x 1
4	819 13 16-10	Washer Flat 13/32 x 1 x 10 Ga.
5	532 14 50-06	Clip Push In Hinged
6	873 80 06-00	Nut Lock Hex 3/8-16 Unc
7	532 12 41-81	Spring Seat Cprsn 2 250 Blk Zi
8	817 00 06-16	Screw 3/8-16 X 1-1/2
9	819 13 16-14	Washer 13/32 X 1 X 14 Ga
10	532 17 48-94	Pan Pnt Seat (blk)
12	532 12 12-46	Bracket Pnt Mounting Switch
13	532 12 12-48	Bushing Snap Blk Nyl 50 Id

KEY NO.	PART NO.	DESCRIPTION
14	872 05 04-12	Bolt Rdhd Sht Nk 1/4-20x1-1/2
15	532 13 43-00	Spacer Split
16	532 12 12-50	Spring Cprsn Plate SW 1.310 Ga
17	532 12 39-76	Nut Lock 1/4 Lge Flg Gr 5 Zinc
21	532 17 18-52	Bolt Shoulder 5/16-18 Unc-2A
22	873 80 05-00	Nut Hex Lock w/Ins 5/16-18
23	871 11 08-14	Bolt Hex Black
24	819 17 19-12	Washer 17/32 X 1-3/16 X 12 Ga.
25	532 12 70-18	Bolt Shoulder 5/16-18 X 62
26	810 04 08-00	Washer Lock Hvy Hlcl Spr 1/2

NOTE: All component dimensions given in U.S. inches.
1 inch = 25.4 mm

REPAIR PARTS

TRACTOR - - MODEL NO. BA14592RBB, PRODUCT NO. 964 77 47-00

DECALS

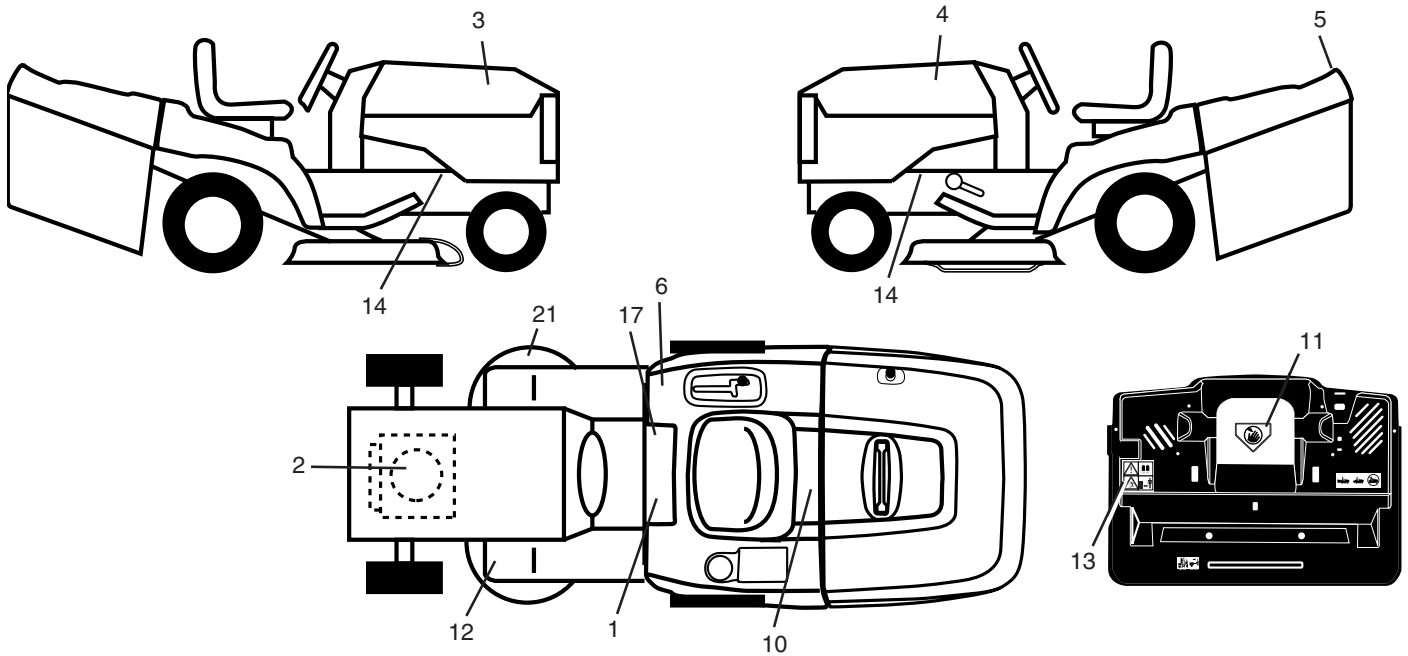

KEY NO.	PART NO.	DESCRIPTION
1	532 14 54-98	Decal Read Owner's Manual Sym
2	532 17 63-96	Decal Hp Engine
3	532 18 16-56	Decal Hood RH
4	532 18 16-57	Decal Hood LH
5	532 18 16-23	Decal Bagger
6	532 18 04-32	Decal 100 DBA/CE
10	532 14 50-05	Decal Bat Dan/Poi P/L Sym Wpn
11	532 14 54-94	Decal Mower Cut Finger Symbol
12	532 15 97-37	Decal Brake/Clutch Symbol Lt

KEY NO.	PART NO.	DESCRIPTION
13	532 18 04-35	Decal Warn Back Plate CRD
14	532 15 97-36	Decal Chassis Hot Muffler
17	532 14 08-37	Decal Saddle Brake Parking
21	532 16 62-86	Decal Hex Belt Sch 92 CRD
—	532 13 83-11	Decal Lift Handle
—	532 18 30-12	Manual Operator's (Euro)
—	532 18 30-13	Manual Operator's (CZ)
—	532 18 31-44	Manual Parts

WHEELS & TIRES

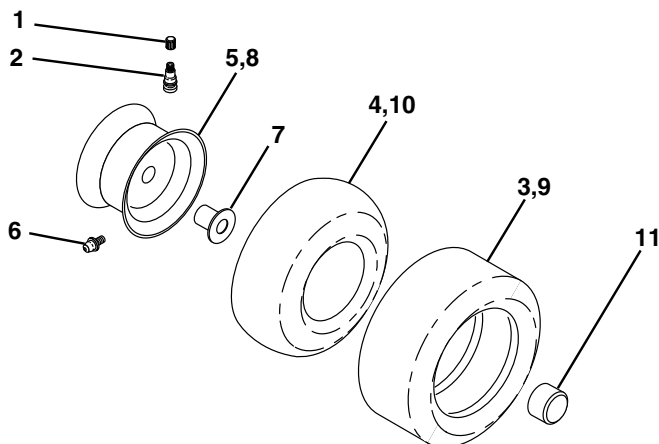

KEY NO.	PART NO.	DESCRIPTION
1	532 05 91-92	Cap Value Tire
2	532 06 51-39	Stem Value
3	532 10 62-22	Tire F Ts 15 X 6 0 - 6 Service
4	532 05 99-04	Tube Inner Front #35060
5	532 12 51-21	Rim Asm 6"front Service
6	532 12 49-57	Fitting Grease
7	532 12 49-59	Bearing Flange
8	532 12 51-22	Rim Asm 8"rear Service
9	532 12 46-35	Tire R Ts 20 x 8-8 Service
10	532 12 49-26	Tube Rear 9 5 X 8 Service
11	532 17 50-39	Cap Axle Blk 1 50 X 1 00
--	532 14 43-34	Sealant, Tire (10 oz. tube)

NOTE: All component dimensions given in U.S. inches
1 inch = 25.4 mm

REPAIR PARTS

TRACTOR - - MODEL NO. BA14592RBB, PRODUCT NO. 964 77 47-00
ENGINE

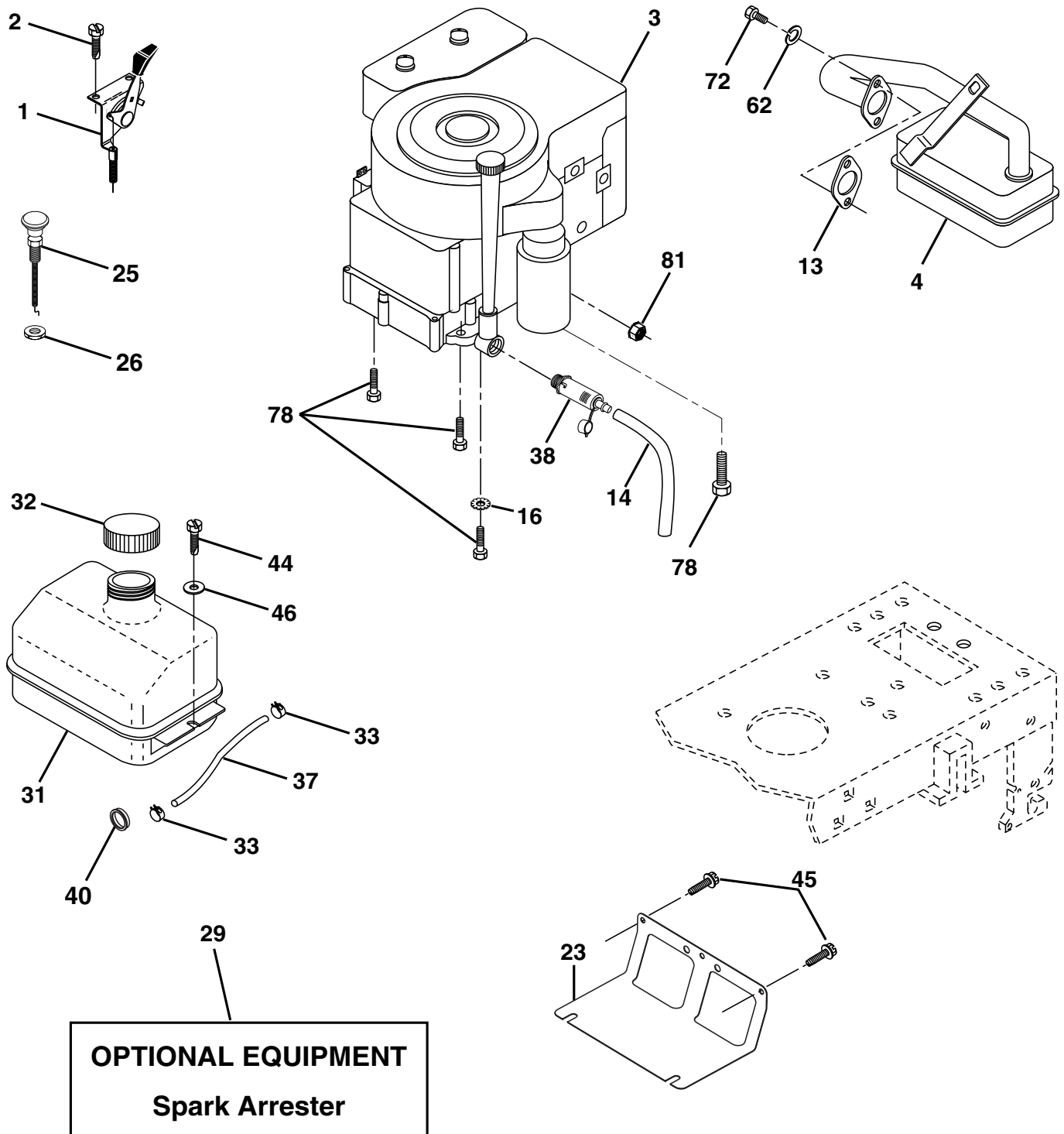

REPAIR PARTS

TRACTOR - - MODEL NO. BA14592RBB, PRODUCT NO. 964 77 47-00 ENGINE

KEY NO.	PART NO.	DESCRIPTION
1	532 17 05-51	Control Throt /Ch
2	817 72 04-08	Screw Hex Thd Cut 1/4-20x5/8 T
3	-----	Engine B&S Model 287707 (Order Parts from Engine Manufacturer)
4	532 13 73-52	Muffler Exhaust B&S Lt
13	532 16 52-91	Gasket 1 313 Id Tin Plated
14	532 14 84-56	Tube Drain Oil Easy
16	811 05 06-00	Washer Lock Ext Tooth 3/8
23	532 16 98-37	Shield Browning/Debris Guard
25	532 18 09-45	Control Choke 1 Cyl.
26	873 92 06-00	Nut Keps 3/8-24 Unf.
29	532 13 71-80	Arrestor Spark
31	532 10 92-02	Tank Fuel
32	532 14 05-27	Cap Asm Fule Top Vent N/Lany
33	532 12 34-87	Clamp Hose Blk
37	532 13 70-40	Line Fuel 20"
38	532 14 83-15	Plug Drain Oil Easy
40	532 12 40-28	Bushing Snap
44	817 67 04-12	Screw Hexwsh Thdrol 3/8-16 x 3/4
45	817 00 06-12	Screw 3/8-16 x 3/4
46	819 09 14-16	Washer 9/32 X 7/8 X 16ga
62	810 04 05-00	Washer Lock Hvy Hlcl Spr 5/16
72	871 07 05-12	Screw Hexhd Cap 5/16-18 x 3/4
78	817 06 06-20	Screw 3/8-16x1-1/4
81	873 51 04-00	Nut Keps Hex 1/4-20 UNC

NOTE: All component dimensions given in U.S. inches
1 inch = 25.4 mm

REPAIR PARTS

TRACTOR - - MODEL NO. BA14592RBB, PRODUCT NO. 964 77 47-00
MOWER LIFT

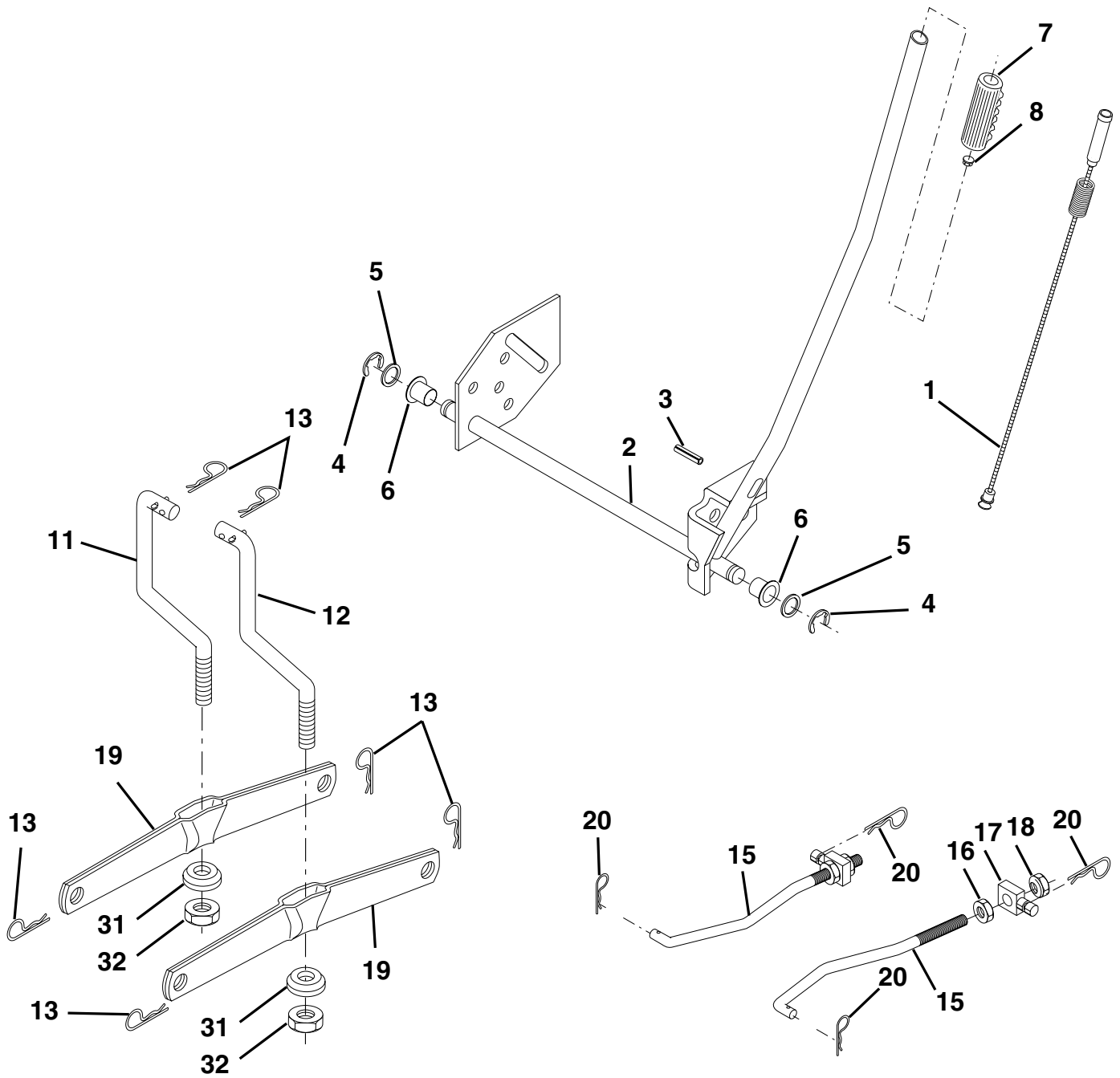

REPAIR PARTS

TRACTOR - - MODEL NO. BA14592RBB, PRODUCT NO. 964 77 47-00
MOWER LIFT

KEY NO.	PART NO.	DESCRIPTION
1	532 15 94-60	Washer Asm Inner Spring W/Plunger
2	532 15 94-71	Shaft Asm. Lift
3	532 10 57-67	Pin Groove
4	812 00 00-02	E Ring #5133-62
5	819 21 16-21	Washer 21/32 x 1 x 21 Ga.
6	532 12 01-83	Bearing Nylon
7	532 10 94-13	Grip Handle Bicycle
8	532 12 45-26	Button Plunger Black
11	532 16 58-29	Link Asm Lift L.H.
12	532 16 58-31	Link Asm Lift R.H.
13	532 12 46-70	Retainer Spring
15	532 17 32-88	Link Front
16	873 35 08-00	Nut Jam Hex 1/2-13 Unc
17	532 17 56-89	Trunnion Blk Zinc
18	873 80 08-00	Nut Lock w/Wsh 1/2-13 Unc
19	532 13 98-68	Arm Suspension Mower
20	532 16 35-52	Retainer Spring
31	532 16 98-65	Bearing, Pvt. Lift.
32	873 54 06-00	Nut Crownlock 3/8-24

NOTE: All component dimensions given in U.S. inches
1 inch = 25.4 mm

REPAIR PARTS

TRACTOR - - MODEL NO. BA14592RBB, PRODUCT NO. 964 77 47-00
MOWER

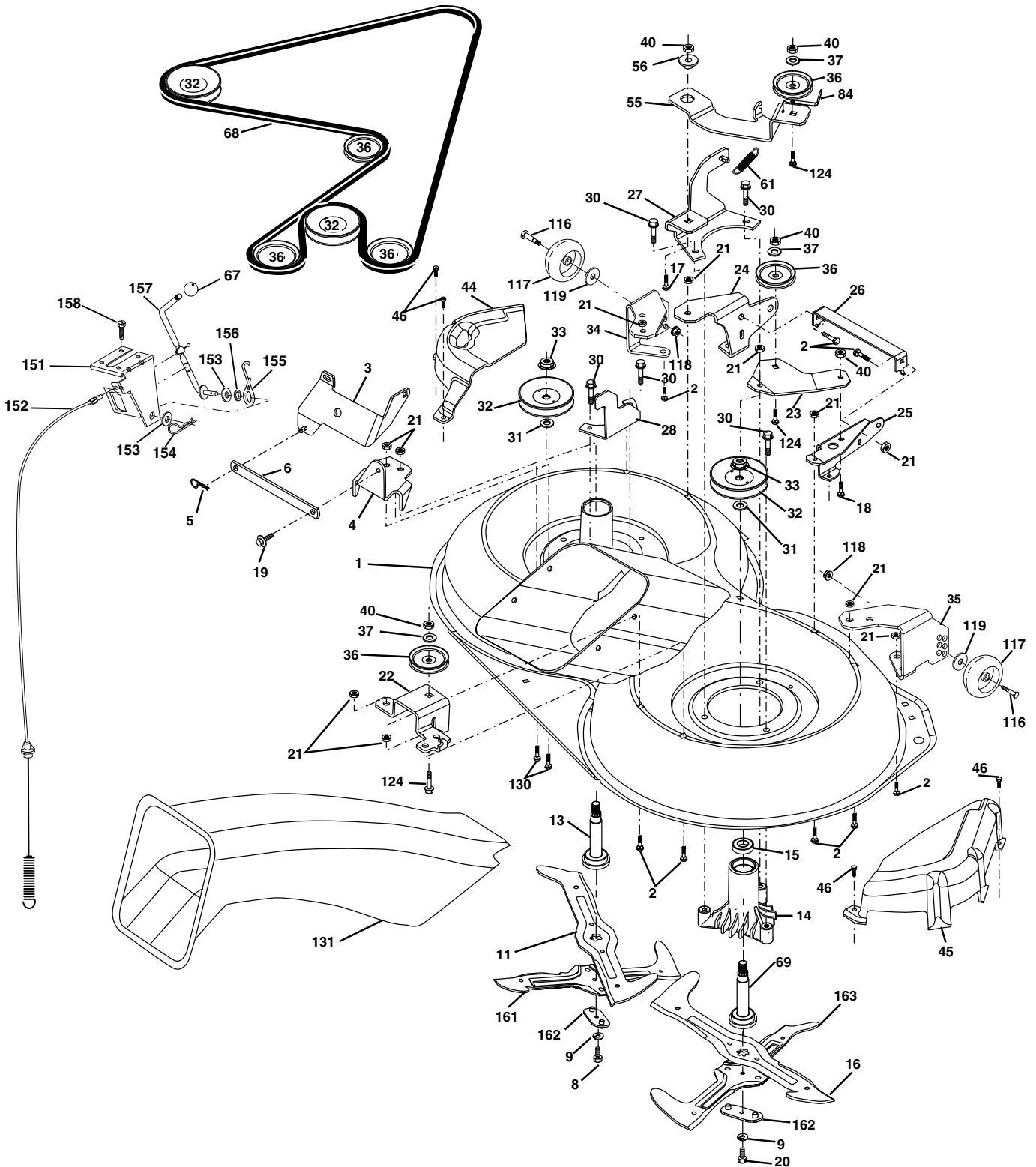

REPAIR PARTS

TRACTOR - - MODEL NO. BA14592RBB, PRODUCT NO. 964 77 47-00
MOWER

KEY NO.	PART NO.	DESCRIPTION
1	532 16 55-52	Housing Asm. Mower
2	872 14 05-06	Bolt Rdhd Sqnk 5/16-18 Unc x 3/4
3	532 16 55-69	Bracket Asm. S-Bar Chass
4	532 16 55-58	Bracket Bar Sway Deck
5	532 12 46-70	Retainer Spring
6	532 16 55-57	Bar Sway
8	532 18 17-12	Bolt 3/8-24 x 1.25 Gr8 Patched
9	810 03 06-00	Washer Lock Hvy 3/8 Unplated
11	532 17 00-37	Blade 3-1 Lh
13	532 13 76-45	Shaft Asm. W/Lower Bearing
14	532 12 87-74	Housing Mandrel Vented (Machd)
15	532 11 04-85	Bearing Ball Mandrel
16	532 17 00-38	Blade 3-1 Rh
17	872 14 06-10	Bolt Carriage 3/8-16 x 1-1/4
18	872 11 06-08	Bolt Rdhd Sqnk 3/8-16 x 1 Gr5
19	532 13 28-27	Bolt Shoulder 5/16-18 Thd Form
20	532 18 17-13	Bolt 3/8-24 x 1.25 Gr8 Ptch Lhthd
21	873 68 05-00	Nut Crown Lock 5/16-18
22	532 16 52-43	Bracket Idler Sprt RR
23	532 16 54-46	Bracket Idler Sprt RF
24	532 16 52-42	Bracket Suspension LF
25	532 16 52-44	Bracket Suspension RF
26	532 16 52-37	Brace Support Susp Frt CRD
27	532 16 55-68	Bracket Asm. Susp RR
28	532 16 55-67	Bracket Asm. Susp LR
30	532 17 39-84	Screw Thd Rolling Washer Head
31	532 12 99-63	Washer Spacer Mower Vented
32	532 15 35-31	Mandrel Pulleys 36 & 46
33	532 17 83-42	Nut Flg Top Lock
34	532 16 52-39	Bracket Gauge Wheel Lf
35	532 16 52-38	Bracket Gauge Wheel Rf
36	532 14 67-63	Pulley Idler V-Groove Dim 4.25
37	819 13 13-16	Washer 11/32 x 13/16 x 16 Ga
40	873 68 06-00	Nut Crownlock 3/8-16 Unc

KEY NO.	PART NO.	DESCRIPTION
44	532 17 55-38	Cover Mandrel Lh
45	532 17 55-39	Cover Mandrel Rh
46	532 13 77-29	Screw Thd Roll 1/4-20 x 5/8
55	532 16 54-45	Arm Idler
56	532 16 57-23	Spacer Retainer PM Mower
61	532 16 59-45	Spring Tension Belt
67	532 10 69-32	Knob Rd 3/8-16 Plstc Thds Blk
68	532 18 02-17	Hex-Belt 92 Mower
69	532 16 54-82	Shaft Asm W/Lwr Brg Rh Thd CRD
84	532 15 60-85	Keeper Belt Idler
116	532 13 76-44	Bolt Shoulder
117	532 13 39-57	Wheel Gage Donut Wide
118	873 93 06-00	Nut Centerlock 3/8-16 Unc
119	819 12 14-14	Washer 3/8 x 7/8 x 14 Ga.
124	872 11 06-12	Bolt Carr Sh 3/8-16 x 1-1/2 Gr5
130	872 11 05-06	Bolt Rdhdsqnk 5/16-18 Unc x 3/4
131	532 16 56-61	Chute Bagger CRD
151	532 16 96-70	Bracket Clutch Cable
152	532 17 60-74	Cable Clutch CRD Service
153	532 16 96-74	Washer Flat 3/8" Type B
154	532 16 96-75	Spring Retainer
155	532 16 96-71	Spring Retainer Lvr Cltch Cab
156	532 16 96-72	Spacer Clutch Cable
157	532 16 96-69	Rod Clutch Cable 3/8"
158	817 72 04-08	Screw Hex Thdcut 1/4-20 x 5/8
161	532 18 04-18	Blade Cross Lh 92
162	532 18 04-20	Adapter Blade Cross
163	532 18 04-19	Blade Cross Rh 92
--	532 18 18-57	Mandrel Asm Service
--	532 18 18-58	Mandrel Asm CRD Lh Threads SVC
--	532 18 17-65	Replacement Mower Complete

NOTE: All component dimensions given in U.S. inches
1 inch = 25.4 mm

REPAIR PARTS

TRACTOR - - MODEL NO. BA14592RBB, PRODUCT NO. 964 77 47-00
BAGGER

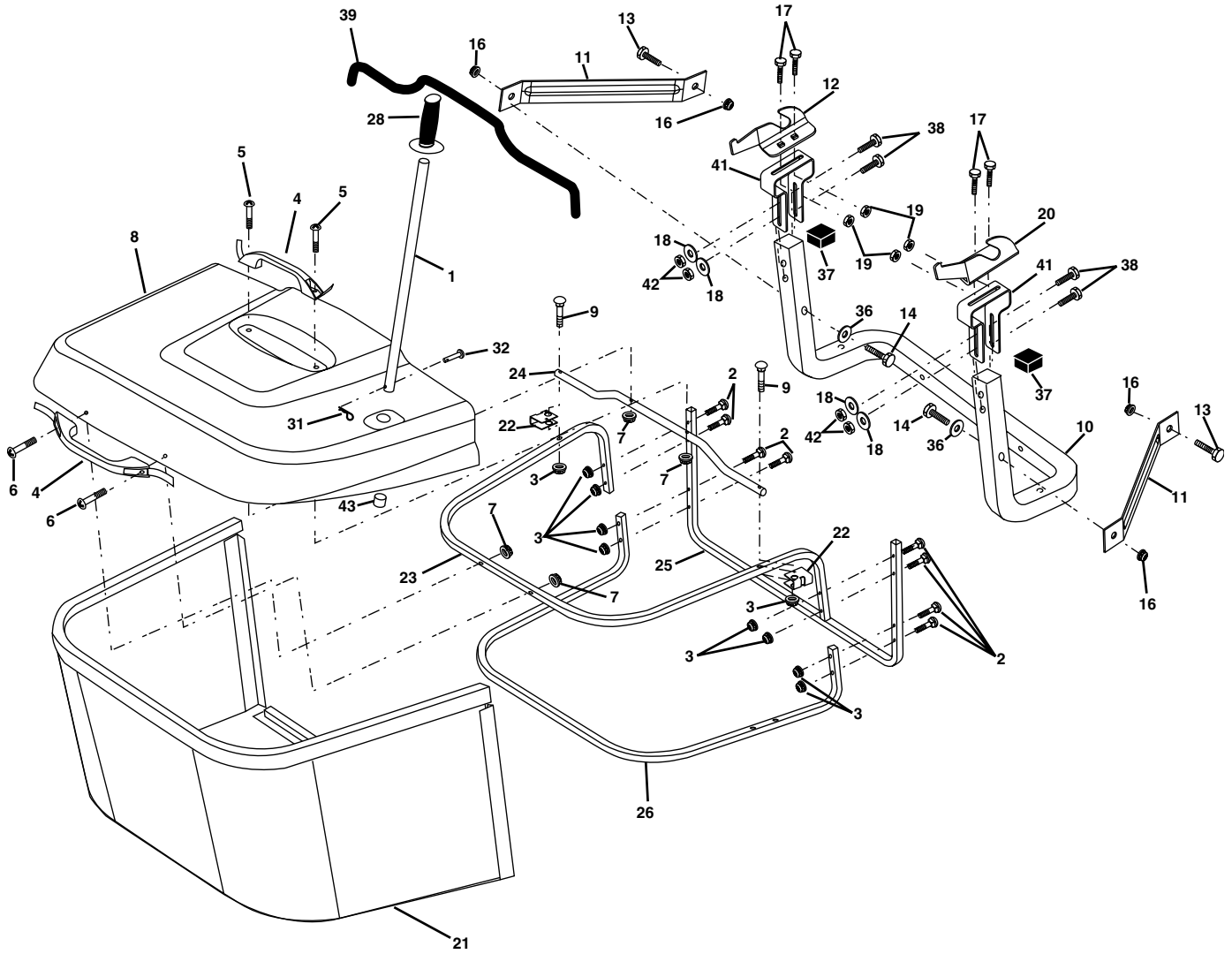

REPAIR PARTS

TRACTOR - - MODEL NO. BA14592RBB, PRODUCT NO. 964 77 47-00
BAGGER

KEY NO.	PART NO.	DESCRIPTION
1	532 16 52-49	Tube Handle Bagger CRD
2	872 14 04-16	Bolt Carriage 1/4-20 X 2.0 Gr.5
3	532 12 39-76	Nut Lock 1/4 Lge Flg Gr. 5 Zinc
4	532 16 99-16	Handle Bagger w/Lvrs Gr. 5 Zinc
5	874 98 10-24	Screw Pan Head #10-24 X 1.50 Blk
6	874 98 10-32	Screw Pan Hd
7	873 40 10-00	Nut Wiz Lock Hex Serr/Hd #10-24
8	532 18 25-14	Cover Bagger Steel
9	872 14 04-18	Bolt Carriage 1/4-20 x 2.25d x Gr.5
10	532 18 12-82	Tube Support Bagger CRD
11	532 16 57-19	Bracket Support Upper Bag CRD
12	532 16 96-85	Bracket Horiz. Adj Bagger
13	872 11 06-06	Bolt Rdhd Sht Sqnk 3/8-16 X 3/4
14	874 52 06-36	Bolt Fin Hex 3/8-16 X 2-1/4 Gr. 5
16	873 90 06-00	Nut Lock Flg 3/8-16 Unc
17	872 14 05-06	Bolt Rdhd Sht Sqnk 5/16-18Unc X 3/4
18	819 11 12-16	Washer 11/32 x 3/4 x 16 Ga.
19	873 90 05-00	Nut Lock Hex Flange 5/16-18
20	532 16 96-84	Bracket Horiz Adj Bagger
21	532 18 08-80	Bag Asm CRD
22	532 16 57-81	Bracket Side Bagger CRD
23	532 16 57-82	Tube Upper Bagger CRD
24	532 16 57-83	Tube Pivot Bagger CRD
25	532 18 01-24	Tube Front Bagger CRD
26	532 16 57-85	Tube Lower Bagger CRD
27	532 16 96-92	Bushing Snap Bagger CRD
28	532 16 57-87	Grip Handle Black
31	532 12 47-88	Retainer Spring 1" Zinc/Cad
32	532 12 68-75	Rivet Rd Hd Drilled 3/8 Dia
36	819 13 20-16	Washer 13/32 x 1-1/4 x 16 Ga.
37	532 17 54-01	Plug Support Bagger CRD
38	872 01 05-20	Bolt 5/16-18 x 2-1/2
39	532 18 09-85	Seal Trim 37"
41	532 16 96-83	Bracket Vert Adj Bagger CRD
42	873 80 05-00	Nut Lock Hx w/Ins 5/16-18 Unc

NOTE: All component dimensions given in U.S. inches
1 inch = 25.4 mm

SERVICE NOTES

SERVICE NOTES

Electrolux Outdoor Products Service Contacts

BELGIQUE/BELGIË

Electrolux Outdoor Products
Tel: 02 363 0311, Fax: 02 363 0391

ČESKÁ REPUBLIKA

Electrolux, spol. S.r.o., oz Electrolux Outdoor Products,
Na Krecku 365 Praha 10 - Horní Mecholupy
Tel: 02/7487 0164, Info-linka: 0800/110 220
Internet: www.partner-flymo.cz E-mail: info@husqvarna.cz

DANMARK

Electrolux Outdoor Products, Flymo/Partner A/S,
Lundtoftegrdsvej 93A, DK 2800 Kgs.Lyngby
Tel: 45 877577, www.flymo-partner.dk

DEUTSCHLAND

Electrolux Outdoor Products
Tel: 097 21 7640, Fax:097 21 764202

ESTONIA

Electrolux Estonia Ltd (Electrolux Eesti AS)
Tel: (372) 6650010

FRANCE

Electrolux Outdoor Products
Tel 01 46 67 8141, Fax 01 43 34 2491

FINLAND SUOMI

Electrolux Outdoor Products Finland
Tel: 00 39611, Fax: 00 39 612632

ITALIA

McCulloch Italiana s.r.l. - Via Como 72, 23868 Valmadrera
(LECCO) - ITALIA, Tel: 800 017829, Fax: 0341 581671

IRELAND

Electrolux Outdoor Products
Tel: 01 4565222, Fax: 01 4568551

MAGYARORSZÁG

Electrolux Lehel Kft
Tel: 00 36 1 251 41 47

NORGE

Electrolux Outdoor Products
Tel: 69 10 47 90

NEDERLAND

Electrolux Outdoor Products BV
Tel: 0172-468322, Fax: 0172-468219

ÖSTERREICH

HUSQVARNA Zentralwerksttte, Industriezeile 36, 4020 LINZ,
Tel: 0732 770101-60, Fax: 0732 795922

POLSKA

Electrolux Poland Sp. z.o.o. Husqvarna, 01-612 Warszawa
Myslowicka 10/2
Tel:- (22) 8332949

SLOVENIJA

HUSQVARNA-Ges.m.b.H. Nfg. KG, Industriezeile 36, 4020 LINZ,
Tel: 0732 77 01 01-0, Fax: 0732 77 01 01.40
Internet: www.husqvarna.at E-mail: office@husqvarna.co.at

SLOVENSKA

Electrolux Slovakia s.r.o., Borova Sihot 211, 033 01 Lipt. Hradok
Tel: 044 522 14 19, Fax: 044 522 14 18, www.flymo-partner.sk

SCHWEIZ/SUISSE/SUIZZERA

Electrolux Outdoor Products
Tel 062 889 93 50 / 889 94 25, Fax 062 889 93 60 / 889 94 35

SVERIGE

Electrolux Outdoor Products, Sverige
Tel: 036 û 14 67 00, Fax: 036 û 14 60 70

UNITED KINGDOM

Electrolux Outdoor Products, United Kingdom
Tel: 01325 300303, Fax: 01325 310339

