

# ILLUSTRATED PARTS BREAKDOWN

**ELECTROLUX  
18.0 HP LAWN TRACTOR  
MODEL NO. 180H122 (PP18H122A)  
964 77 11-00**

# TRACTOR - MODEL NO. 180H122 (PP18H122A), PRODUCT NO. 964 77 11-00 SCHEMATIC

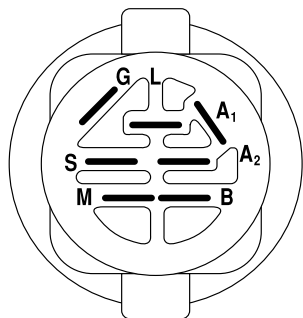
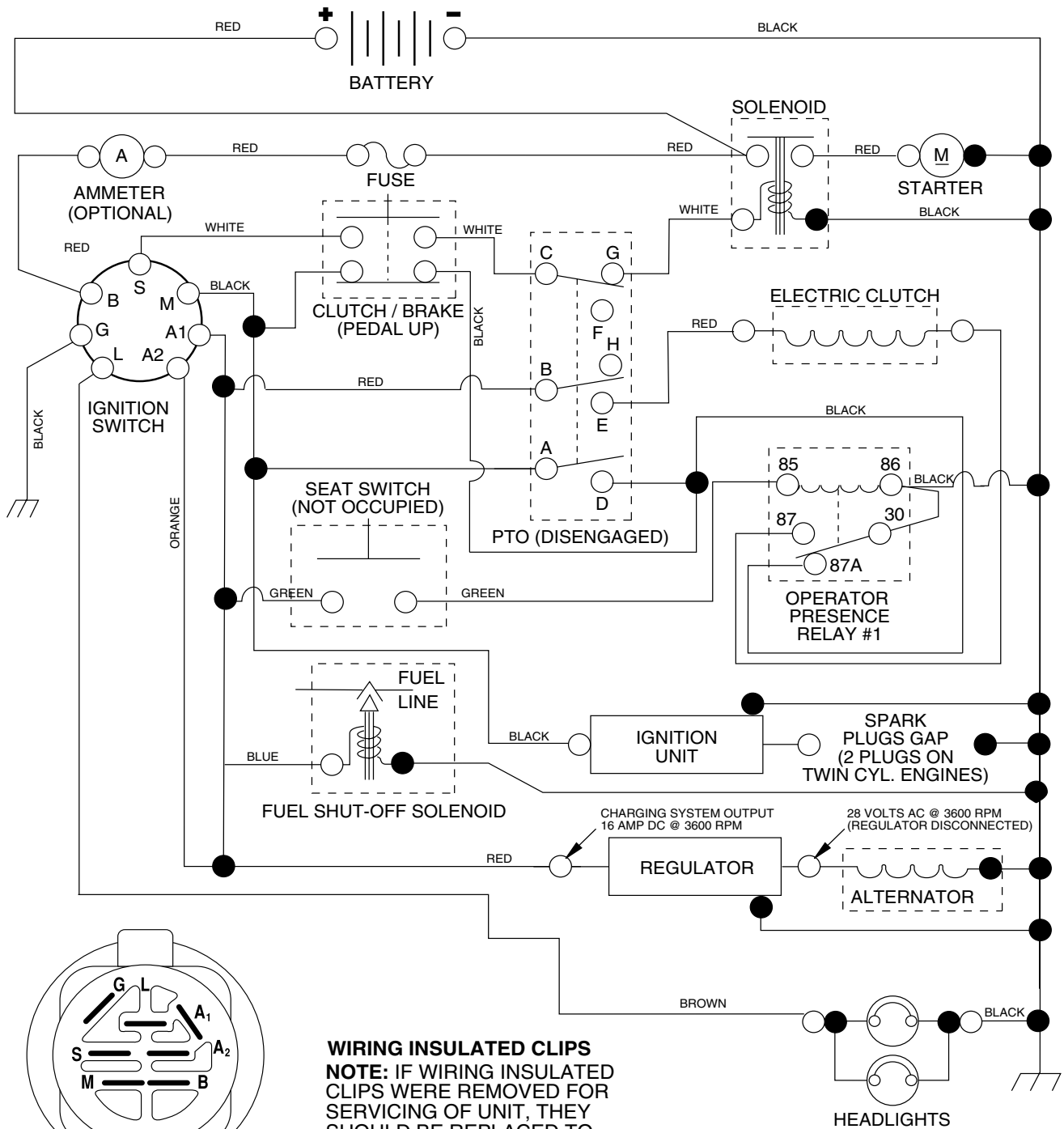

**IGNITION SWITCH**

POSITION	CIRCUIT	"MAKE"
OFF	M+G+A1	NONE
RUN/LIGHT	B+A1	A2+L
RUN	B+A1	NONE
START	B + S + A1	NONE

**WIRING INSULATED CLIPS**  
NOTE: IF WIRING INSULATED CLIPS WERE REMOVED FOR SERVICING OF UNIT, THEY SHOULD BE REPLACED TO PROPERLY SECURE YOUR WIRING.

**PTO SWITCH**

POSITION	CIRCUIT
OFF	C + G, B + H
ON	C + F, B + E, A + D

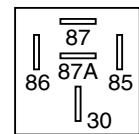
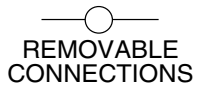

**RELAY**

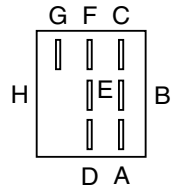

# REPAIR PARTS

TRACTOR - MODEL NO. 180H122 (PP18H122A), PRODUCT NO. 964 77 11-00  
ELECTRICAL

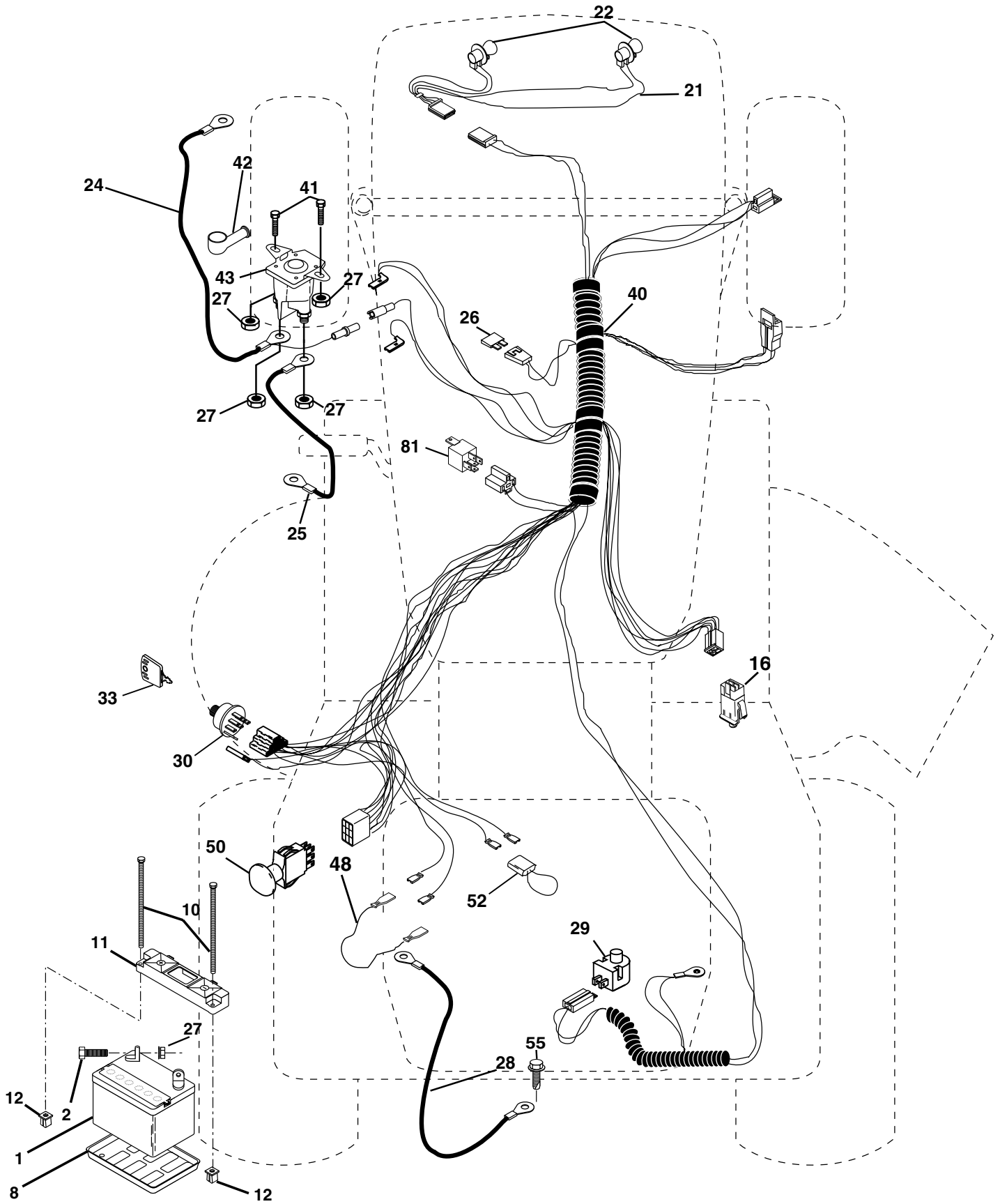

# REPAIR PARTS

TRACTOR - MODEL NO. 180H122 (PP18H122A), PRODUCT NO. 964 77 11-00  
ELECTRICAL

KEY NO.	PART NO.	DESCRIPTION
1	532 14 49-27	Battery
2	874 76 04-12	Bolt Hex Hd 1/4-20unc X 3/4
8	532 00 76-03	Tray Battery
10	532 14 52-11	Bolt 1/4-20 x 7.5
11	532 15 01-09	Holddown Battery
12	532 14 57-69	Nut Push Nylong 1/4"
16	532 17 61-38	Switch Interlock
21	532 17 56-88	Harness Socket Light
22	532 00 41-52	Bulb, Light # 1156
24	532 12 47-80	Cable Battery
25	532 14 61-48	Cable Battery
26	532 17 51-58	Fuse
27	873 51 04-00	Nut Keps Hex 1/4-20 Unc
28	532 14 54-91	Cable Ground
29	532 16 07-84	Switch Plunger
30	532 17 55-66	Switch Ign
33	532 14 04-01	Key Ign Molded Generic
40	532 17 97-24	Harness Ign
41	871 11 04-08	Bolt Fin Hex 1/4-20uncx 1/2
42	532 13 15-63	Cover Terminal Red
43	532 17 88-61	Solenoid
48	532 14 08-44	Adapter Ammeter
50	532 17 46-53	Switch PTO
52	532 14 19-40	Protection Loop
55	817 49 05-08	Screw Thdrol 5/16-18 x 1/2
81	532 10 97-48	Relay Asm.

**NOTE:** All component dimensions given in U.S. inches  
1 inch = 25.4 mm

# REPAIR PARTS

TRACTOR - MODEL NO. 180H122 (PP18H122A), PRODUCT NO. 964 77 11-00  
CHASSIS

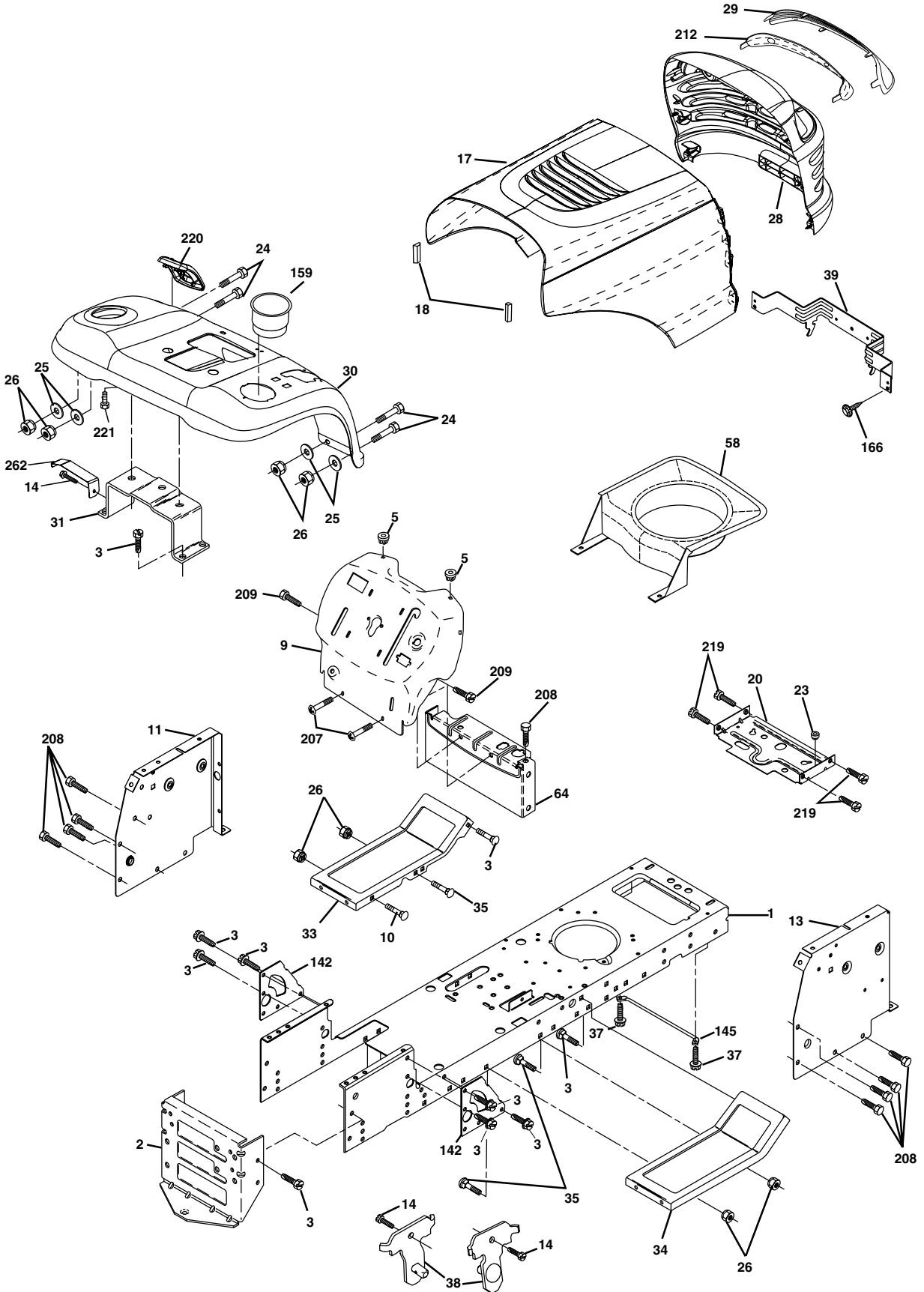

# REPAIR PARTS

TRACTOR - MODEL NO. 180H122 (PP18H122A), PRODUCT NO. 964 77 11-00  
CHASSIS

KEY NO.	PART NO.	DESCRIPTION
1	532 17 46-19	Chassis
2	532 17 65-54	Drawbar
3	817 06 06-12	Screw 3/8-16 X .75
5	532 15 52-72	Bumper Hood/Dash
9	532 18 59-50	Dash P/L
10	872 14 06-08	Bolt Carriage 3/8-16 x 1
11	532 17 49-96	Panel Dash Lh
13	532 17 21-06	Panel Dash Rh
14	817 49 06-08	Screw Thdrol 3/8-16 x 1/2
17	532 18 27-16	Hood
18	532 18 49-21	Bumper Hood
20	532 18 06-79	Plate Mtg Battery Fuel Tank Fr
23	532 12 40-28	Bushing
24	874 78 06-16	Bolt Fin Hex 3/8-16 x 1 Gr 5
25	819 13 13-12	Washer 13/32 X 13/16 X 12 Ga
26	873 80 06-00	Nut Lock Hex W/Ins 3/8-16 Unc
28	532 17 97-49	Grille/Lens Asm
29	532 18 27-18	Lens LT/PL
30	532 18 30-52	Fender
31	532 18 35-69	Bracket Fender
33	532 18 25-07	Footrest Pnt Lh
34	532 18 25-08	Footrest Pnt Rh
35	872 11 06-06	Bolt Rdhd Sht Sqnk 3/8-16 x 3/4
37	817 49 05-08	Screw Thdrol 6/16-18 x 1/2 TYT
38	532 17 57-10	Bracket Asm Pivot Mower Rear
39	532 17 47-14	Bracket Pivot Laser LT
58	532 17 49-30	Duct Air
64	532 15 47-98	Dash Lower STLT
142	532 17 57-02	Plate Reinforcement STLT
145	532 15 65-24	Rod Pivot Chassis/Hood
159	532 18 28-79	Cupholder
166	532 17 18-75	Screw Hi-Lo #13-16 x 3/4
207	817 67 05-08	Screw Thdrol 5/16-18 x 1/2
208	817 67 06-08	Screw Thdrol 3/8-16 x 1/2
209	817 00 06-12	Screw Hex Wsh Thdrol 3/8-16 X 3/4
212	532 17 51-43	Insert Lens Relect
219	817 00 05-12	Screw 5/16-18 x 3/4
220	532 18 28-82	Console Fuel Window
221	532 14 24-32	Screw Hex Wsh Hi-Lo 1/4-1/2
262	532 18 35-54	Bracket Support Tank
--	532 00 54-79	Plug

**NOTE:** All component dimensions given in U.S. inches  
1 inch = 25.4 mm

# REPAIR PARTS

TRACTOR - MODEL NO. 180H122 (PP18H122A), PRODUCT NO. 964 77 11-00  
DRIVE

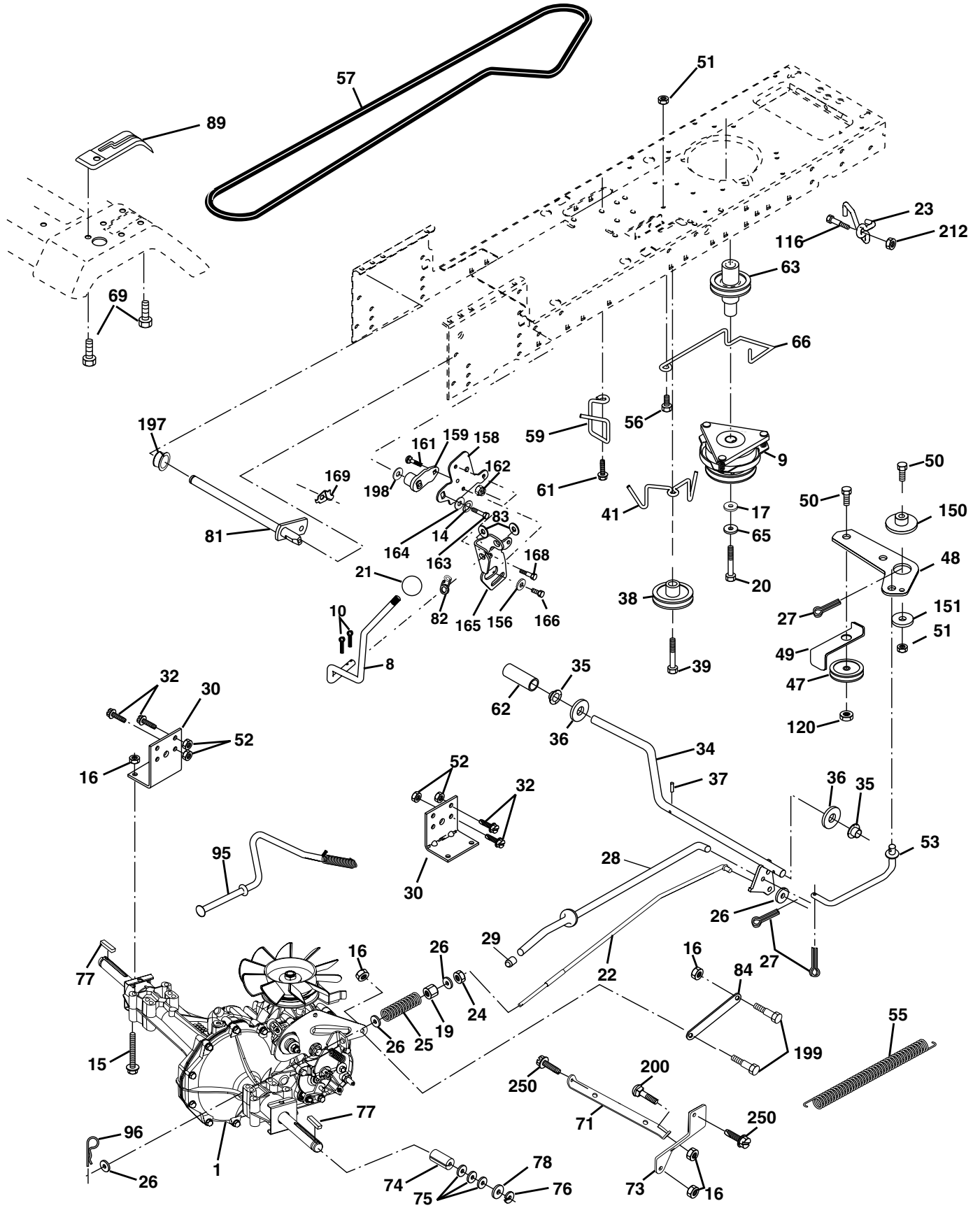

# REPAIR PARTS

**TRACTOR - MODEL NO. 180H122 (PP18H122A), PRODUCT NO. 964 77 11-00  
DRIVE**

KEY NO.	PART NO.	DESCRIPTION	KEY NO.	PART NO.	DESCRIPTION
1	-----	Transaxle, Hydro Gear 314-0510 (Order Parts From Transaxle Manufacturer)	63	532 17 46-07	Pulley, Engine
8	532 16 60-20	Rod Shift Fender	65	810 04 07-00	Washer
9	532 17 93-34	Clutch Electric	66	532 15 47-78	Keeper Belt Engine Hydro
10	876 02 04-16	Pin Cotter 1/8 x 1 CAD	69	532 14 24-32	Screw Hex Wsh Hi-Lo 1/4-1/2
14	810 04 04-00	Washer Lock Hvy Helical	71	532 16 91-83	Strap Torque Lh Hydro
15	874 49 05-44	Bolt Hex Flghd 5/16-18 Gr. 5	73	532 16 91-82	Strap Torque Rh Hydro
16	873 80 05-00	Nut Lock Hex W/Ins. 5/16-18 Unc	74	532 13 70-57	Spacer, Axle
19	873 80 06-00	Nut Lock Hex W/Wsh 3/8-16 Unc	75	532 12 17-49	Washer 25/32 x 1-1/4 x 16 Ga.
20	532 17 39-37	Bolt, Hex 7/16-20 x 4	76	812 00 00-01	E-Ring
21	532 14 08-45	Knob	77	532 12 35-83	Key, Square
22	532 16 94-98	Rod, Brake Hydro	78	532 12 17-48	Washer 25/32 x 1-5/8 x 16 Ga.
23	532 17 82-89	Bracket Asm. Anti-Rot	81	532 16 55-96	Shaft Asm. Cross Hydro
24	873 35 06-00	Locknut	82	532 16 57-11	Spring Torsion T/A
25	532 10 68-88	Spring, Brake Rod	83	819 17 12-16	Washer 17/32 x 3/4 x 16 Ga.
26	819 13 13-16	Washer	84	532 16 95-94	Link Transaxle
27	876 02 04-12	Pin Cotter 1/8 x 3/4 CAD.	89	532 18 28-86	Console, Shift
28	532 17 57-65	Rod, Parking Brake	95	532 17 02-01	Control Asm. Bypass Hydro
29	532 07 16-73	Cap, Parking Brake	96	532 12 47-88	Retainer Spring 1" Zinc/Cad
30	532 16 95-92	Bracket, Transaxle	116	872 14 06-08	Bolt RdHd Sqnk 3/8-16 x 1
32	874 76 05-12	Bolt Hex Hd 5/16-18 Unc x 3/4	120	873 90 06-00	Nut Lock 3/8-16
34	532 17 55-78	Shaft, Foot Pedal Nibbed	150	532 17 54-56	Spacer Retainer
35	532 12 01-83	Bearing, Nylon	151	819 13 32-10	Washer 13/32 x 2 x 10 Ga.
36	819 21 16-16	Washer	156	532 16 60-02	Washer Srrtd 5/16ID x 1.125
37	532 12 49-63	Pin, Roll	158	532 16 55-89	Bracket Shift Mount
38	532 17 91-14	Pulley, Idler, Flat Composite	159	532 18 39-00	Hub Tapered Flange Shift Lt
39	874 76 06-48	Bolt	161	872 14 04-06	Bolt Rdhd Sqnk 1/4-20 x 3/4 Gr. 5
41	532 17 55-56	Keeper, Belt Idler Fool-Proof	162	873 68 04-00	Nut Crownlock 1/4-20 Unc
47	532 12 77-83	Pulley, Idler, V-Groove	163	874 78 04-16	Bolt Hex Fin 1/4-20 Unc x 1 Gr. 5
48	532 15 44-07	Bellcrank Clutch Grnd Drv Stl	164	819 09 10-10	Washer 5/8 x .281 x 10 Ga
49	532 12 32-05	Retainer, Belt	165	532 16 56-23	Bracket Pivot Lever
50	872 11 06-12	Bolt Carr Sh 3/8-16 x 1-1/2	166	532 16 68-80	Screw 5/16-18 x 5/8
51	873 68 06-00	Nut	168	532 16 54-92	Bolt Shoulder 5/16-18 x .561
52	873 68 05-00	Nut Crown Lock 5/16-18	169	532 16 55-80	Plate Fastening Lt\
53	532 10 57-10	Link, Clutch	197	532 16 96-13	Nyliner Snap-In 5/8" ID
55	532 10 57-09	Spring, Return, Clutch	198	532 16 95-93	Washer Nyliner 7/8 ID x .105
56	817 06 06-20	Screw 3/8-16 x 1-1/4	199	532 16 96-12	Bolt Shoulder 5/16-18 Unc
57	532 14 02-94	V-Belt, Ground Drive	200	872 14 05-08	Bolt Rdhd Sq Neck 5/16-18UNC x 1
59	532 16 96-91	Keeper, Center Span	212	532 14 52-12	Nut Hex Flg. Lock
61	817 12 06-14	Screw 3/8-16 x .875	250	817 06 06-12	Screw 3/8-16 x .75
62	532 12 48-72	Cover, Pedal			

**NOTE:** All component dimensions given in U.S. inches  
1 inch = 25.4 mm



# REPAIR PARTS

## TRACTOR - MODEL NO. 180H122 (PP18H122A), PRODUCT NO. 964 77 11-00 STEERING ASSEMBLY

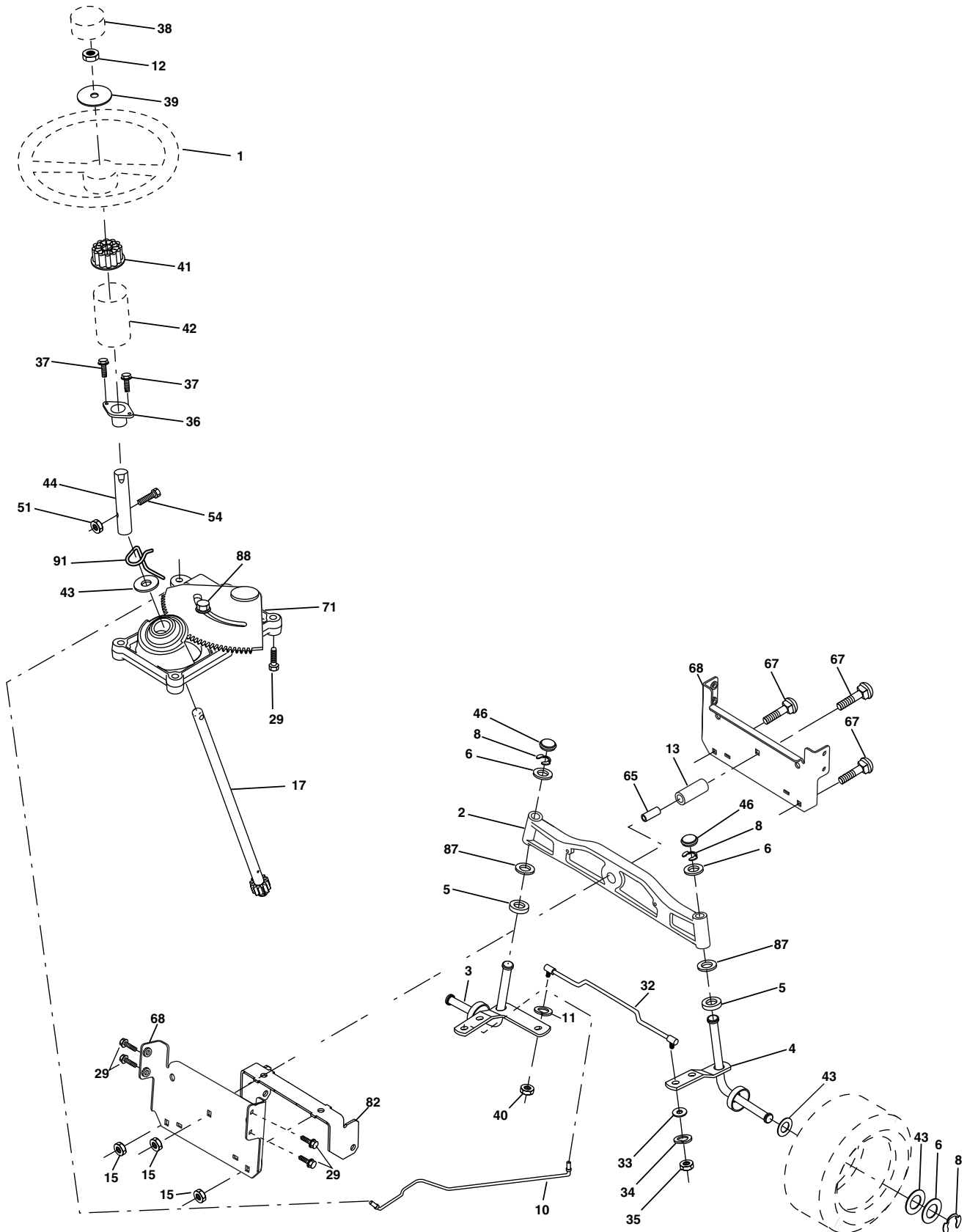

# REPAIR PARTS

TRACTOR - MODEL NO. 180H122 (PP18H122A), PRODUCT NO. 964 77 11-00  
STEERING ASSEMBLY

KEY NO.	PART NO.	DESCRIPTION
1	532 17 20-92	Wheel Steering
2	532 17 23-93	Axle Casting Iron Lt
3	532 16 98-40	Spindle Asm LH
4	532 16 98-39	Spindle Asm RH
5	532 12 49-31	Washer Thrust .75 x 1.230
6	532 12 17-48	Washer 25/32 X 1-5/8 X 16 Ga
8	812 00 00-29	Ring Klip #t5304-75
10	532 17 51-21	Draglink
11	810 04 06-00	Washer Lock Hvy Hlcl Spr 3/8
12	873 94 08-00	Nut Hex Jam Toplock 1/2-20 UNF
13	532 13 65-18	Spacer Bearing Axle Front
15	532 14 52-12	Nut Hex Flange Lock
17	532 18 06-41	Shaft Asm Strg
29	817 06 06-12	Screw 3/8-16 x 3/4
32	532 18 05-80	Rod Asm Tie
33	819 12 14-14	Washer 3/8 x 7/8 x 14 Ga.
34	810 04 06-00	Washer Lock Hvy HLCL Spr. 3/8
35	532 12 47-01	Nut Lock 3/8-24 Unf
36	532 15 51-05	Bushing Strg
37	532 15 29-27	Screw TT #32.5 x 5 x 3/8 Flange
38	532 17 20-93	Insert Cap Strg Wh
39	819 18 24-11	Washer 9/16 x 1-1/2
40	532 12 47-01	Nut Lock Center 3/8-24 Unf
41	532 15 99-45	Adaptor Wheel Strg
42	532 16 96-33	Boot Steering
43	532 12 17-49	Washer 25/32 X 1 1/4 X 16 Ga
44	532 18 06-40	Extension Steering
46	532 12 12-32	Cap Spindle Fr Top Blk
51	873 54 04-00	Nut Crownlock 1/4-28
54	871 13 04-20	Bolt Hex 1/4-28 UNF x 1-1/4 Gr. 8
65	532 16 03-67	Spacer Axle Brace
67	872 14 06-18	Bolt Rdhd Sqnk 3/8-16unc x 2-1/4
68	532 16 98-27	Brace Axle
71	532 17 51-46	Steering Asm.
82	532 16 98-35	Bracket Susp Chassis Front
87	532 17 39-66	Washer Flat .781 x 1-1/2 x .14
88	532 17 51-18	Bolt Shoulder 7/16-20
91	532 17 55-53	Clip Steering

**NOTE:** All component dimensions given in U.S. inches  
1 inch = 25.4 mm

# REPAIR PARTS

## TRACTOR - MODEL NO. 180H122 (PP18H122A), PRODUCT NO. 964 77 11-00 SEAT ASSEMBLY

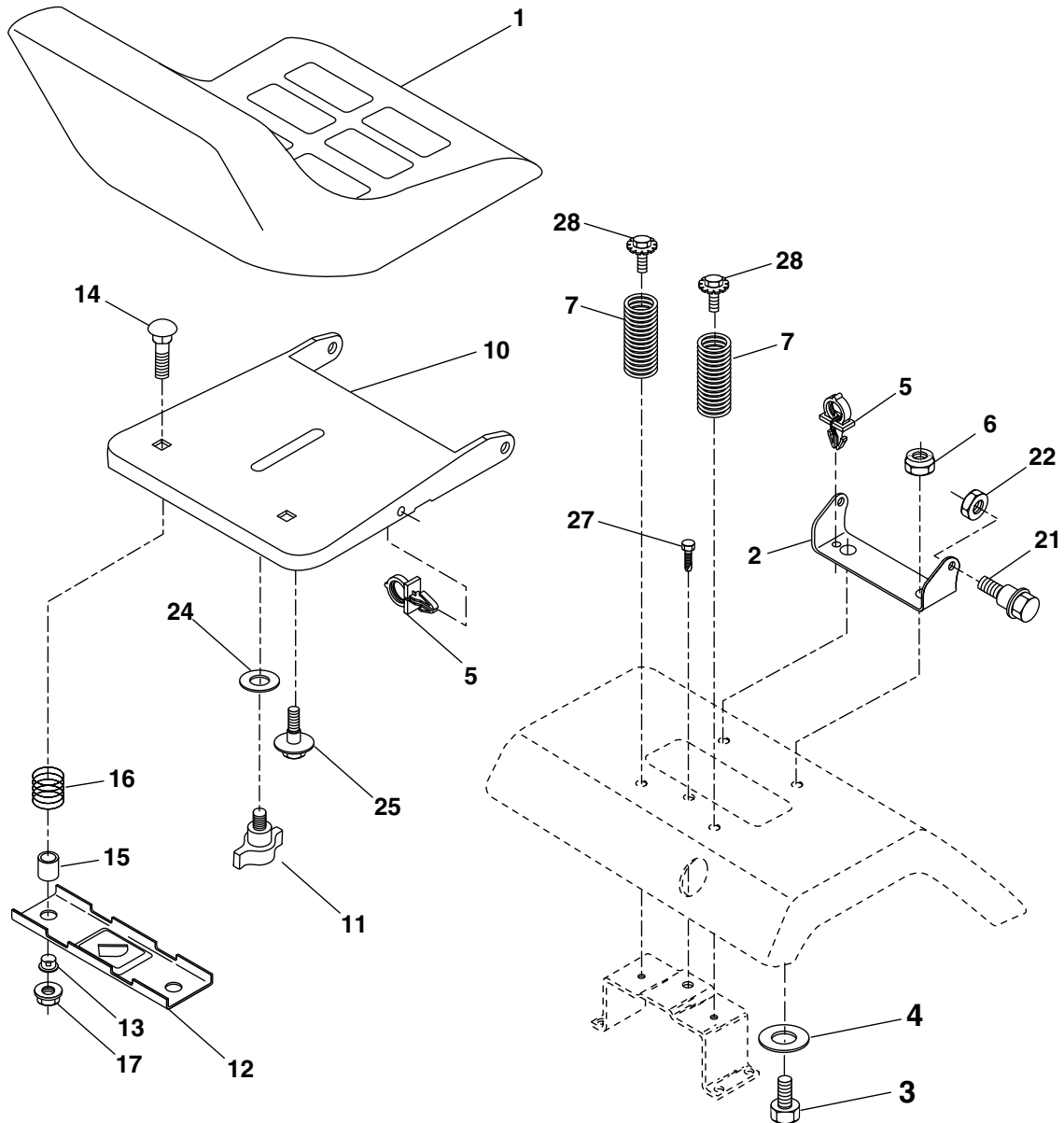

KEY NO.	PART NO.	DESCRIPTION
1	532 17 16-83	Seat
2	532 14 05-51	Bracket Pivot Seat 8 720
3	871 11 06-16	Bolt Fin Hex 3/8-16 Unc x 1
4	819 13 16-10	Washer Flat 13/32 x 1 x 10 Ga.
5	532 14 50-06	Clip Push-In Hinged
6	873 80 06-00	Nut Lock Hex w/Ins. 3/8-16 Unc
7	532 12 41-81	Spring Seat Cprsn 2 250 Blk Zi
10	532 18 24-93	Pan Seat
11	532 16 63-69	Knob Seat
12	532 12 12-46	Bracket Mounting Switch
13	532 12 12-48	Bushing Snap Blk Nyl 50 Id
14	872 05 04-12	Bolt Rdhd Sht Nk 1/4-20x1-1/2

KEY NO.	PART NO.	DESCRIPTION
15	532 13 43-00	Spacer Split 28 x 96 Yel Zinc
16	532 12 12-50	Spring Cprsn Blk Pnt
17	532 12 39-76	Nut Lock 1/4 Lge Flg Gr 5 Zinc
21	532 17 18-52	Bolt Shoulder 5/16-18 Unc-2A
22	873 80 05-00	Nut Lock Hx W/Ins 5/16-18unc
24	819 17 19-12	Washer 17/32 X 1-3/16 X 12 Ga
25	532 12 70-18	Bolt Shoulder 5/16-18 X 62
27	817 49 06-08	Screw Thdrol 3/8-16 x 1/2
28	532 17 18-77	bolt 5/16-18 x 3/4 w/Sems

**NOTE:** All component dimensions given in U.S. inches  
1 inch = 25.4 mm

# REPAIR PARTS

TRACTOR - MODEL NO. 180H122 (PP18H122A), PRODUCT NO. 964 77 11-00  
DECALS

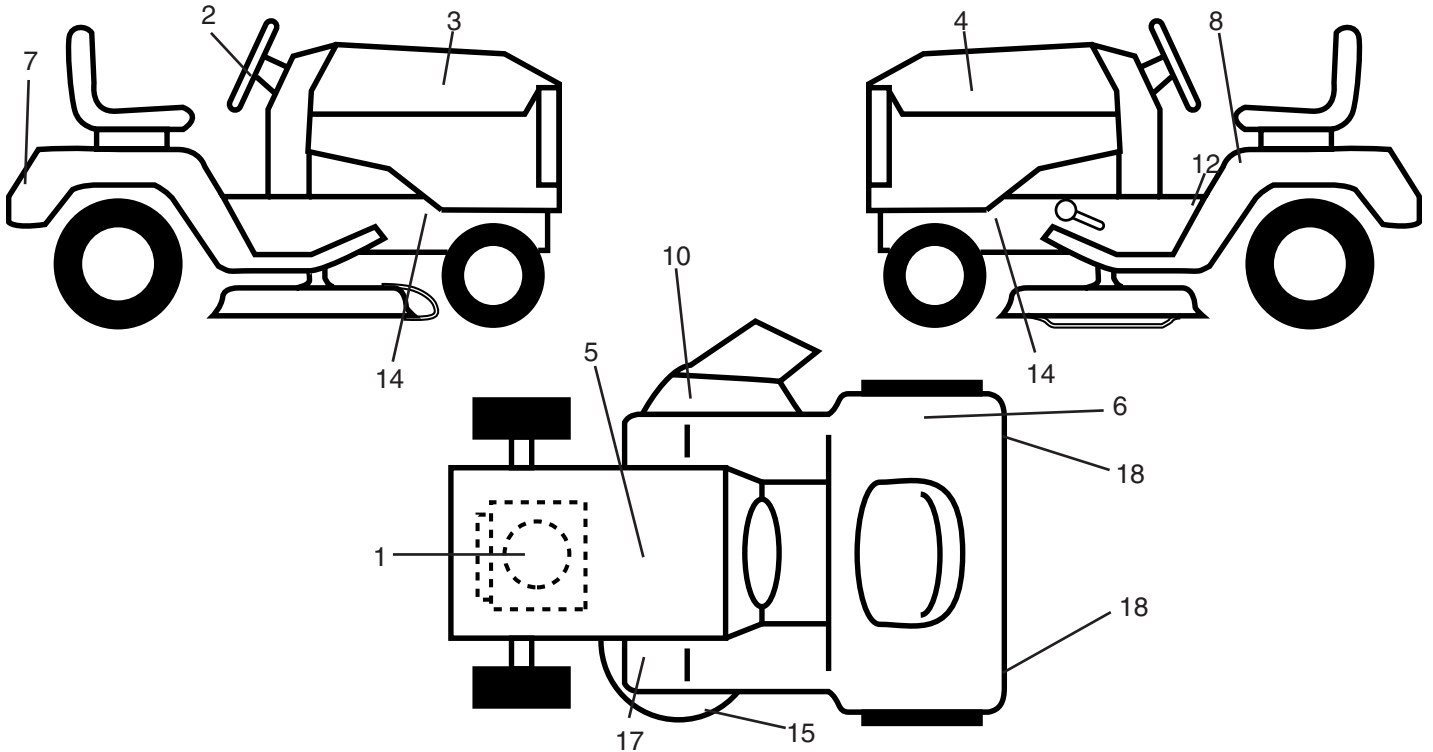

KEY NO.	PART NO.	DESCRIPTION
1	532 18 07-07	Decal Engine
2	532 18 58-85	Decal Ins. Strg. Whl.
3	532 18 58-82	Decal Hood RH
4	532 18 58-83	Decal Hood LH
5	532 14 50-05	Decal Btry DNGR/PSN P/L Sym.
6	532 18 04-33	Decal 105 DBA
7	532 18 58-84	Decal Fender
8	532 14 54-98	Decal Read Owners Manual
10	532 18 21-66	Decal Mower Cutfinger
12	532 14 08-37	Decal Saddle Brake Parking
14	532 15 97-36	Decal Chassis Hot Muffler

KEY NO.	PART NO.	DESCRIPTION
15	532 17 52-91	Decal V-Belt
17	532 15 97-37	Decal Brake/Clutch Symbol LT
18	532 10 62-02	Reflectors
-	532 16 25-98	Decal Drawbar Load Limit
-	532 13 83-11	Decal Lift Handle(Lift Handle)
-	532 16 92-10	Decal By Pass Lt Hydro
-	532 18 10-91	Pad Footrest LH
-	532 18 10-90	Pad Footrest RH
-	532 18 30-33	Manual Oper. Euro.
-	532 18 30-34	Manual Oper. Scan.

## WHEELS AND TIRES

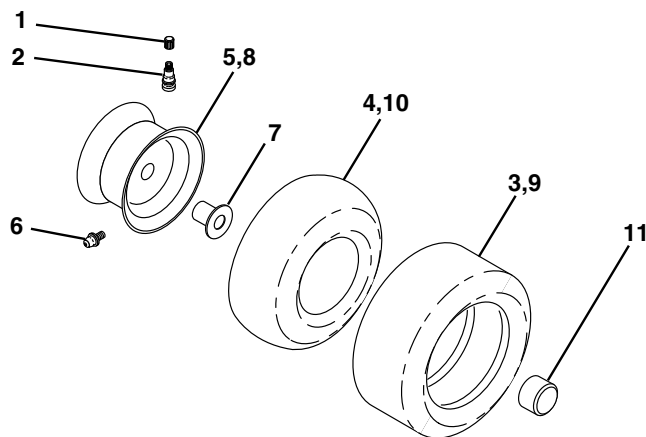

KEY NO.	PART NO.	DESCRIPTION
1	532 05 91-92	Cap Valve Tire
2	532 06 51-39	Stem Valve
3	532 17 04-55	Tire F Tm 15 X 6 0 - 6 Service
4	532 05 99-04	Tube Front (Service Item Only)
5	532 12 51-21	Rim Asm 6" front Service
6	532 12 49-57	Fitting Grease (Front Wheel Only)
7	532 12 49-59	Bearing Flange (Front Wheel Only)
8	532 12 51-22	Rim Asm 8" rear Service
9	532 17 04-56	Tire R Tm 20 x 10 C Service
10	532 12 49-26	Tube Rear (Service Item Only)
11	532 17 50-39	Cap, Hub Axle Blk 1.50 x 1.00
--	532 14 43-34	Tire, Sealant (10 oz. Tube)

**NOTE:** All component dimensions given in U.S. inches  
1 inch = 25.4 mm

# REPAIR PARTS

TRACTOR - MODEL NO. 180H122 (PP18H122A), PRODUCT NO. 964 77 11-00  
ENGINE

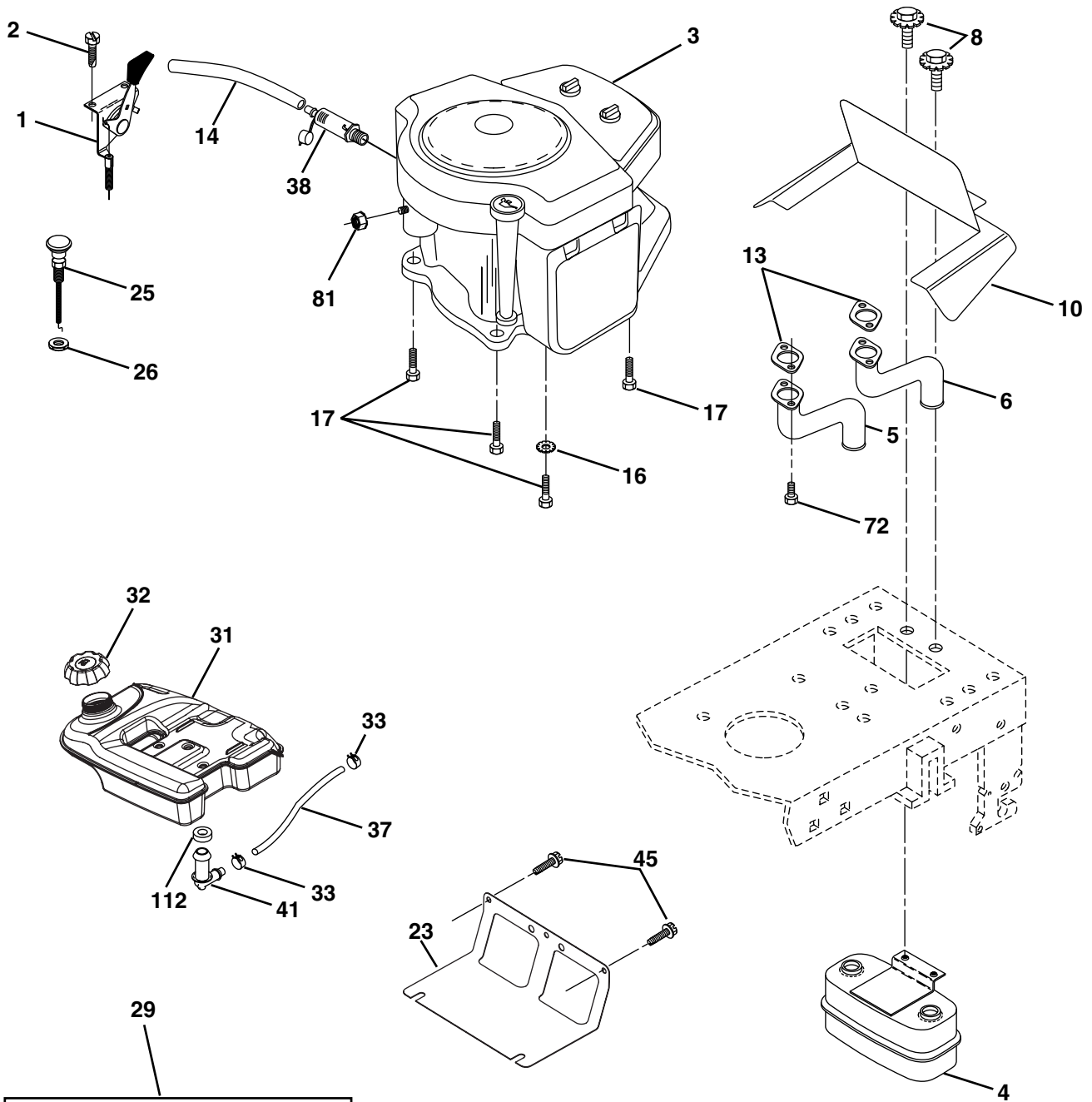

**OPTIONAL EQUIPMENT**  
**Spark Arrester**

# REPAIR PARTS

TRACTOR - MODEL NO. 180H122 (PP18H122A), PRODUCT NO. 964 77 11-00  
ENGINE

KEY NO.	PART NO.	DESCRIPTION
1	532 17 07-71	Control Throt
2	817 72 04-08	Screw Thd Cut 1/4-20 x 1/2
3	-----	Engine Briggs & Stratton Model #407677 Order parts from engine manufacturer
4	532 14 97-23	Muffler Twin Lo-Twin
5	532 15 99-55	Tube, Manifold Lh
6	532 16 05-89	Tube, Manifold Rh
8	532 17 18-77	Bolt 5/16-18 Unc x 3/4 w/Sems
10	532 16 27-97	Shield Browning Intek
13	532 16 53-91	Gasket Muffler
14	532 14 84-56	Tube Drain Oil Easy
16	811 05 06-00	Washer Lock Ext Tooth 3/8
17	817 06 06-24	Screw, Thdrol 3/8-16 x 1-1/2 Tytt
23	532 16 98-37	Shield Brn/Dbr Guard
25	532 14 59-96	Choke Control
26	873 92 06-00	Nut, Keps 3/8-24 Unf
29	532 13 71-80	Kit Spark Arrestor (Flat Scrn)
31	532 17 91-15	Tank Fuel 5.0 STLT w/o Sensor
32	532 18 29-02	Cap Asm Fuel
33	532 12 34-87	Clamp Hose Blk
37	532 14 21-58	Line Fuel
38	532 18 16-54	Plug Drain Oil Easy
41	532 13 92-77	Stem Tank Fuel
45	817 00 06-12	Screw Hex Wsh Thdrol 3/8-16
72	532 18 39-06	Screw Socket Head 5/16-18 x 1
81	873 51 04-00	Nut Keps Hex 1/4-20 Unc
112	532 00 36-45	Bushing

**NOTE:** All component dimensions given in U.S. inches  
1 inch = 25.4 mm

# REPAIR PARTS

TRACTOR - MODEL NO. 180H122 (PP18H122A), PRODUCT NO. 964 77 11-00  
MOWER DECK

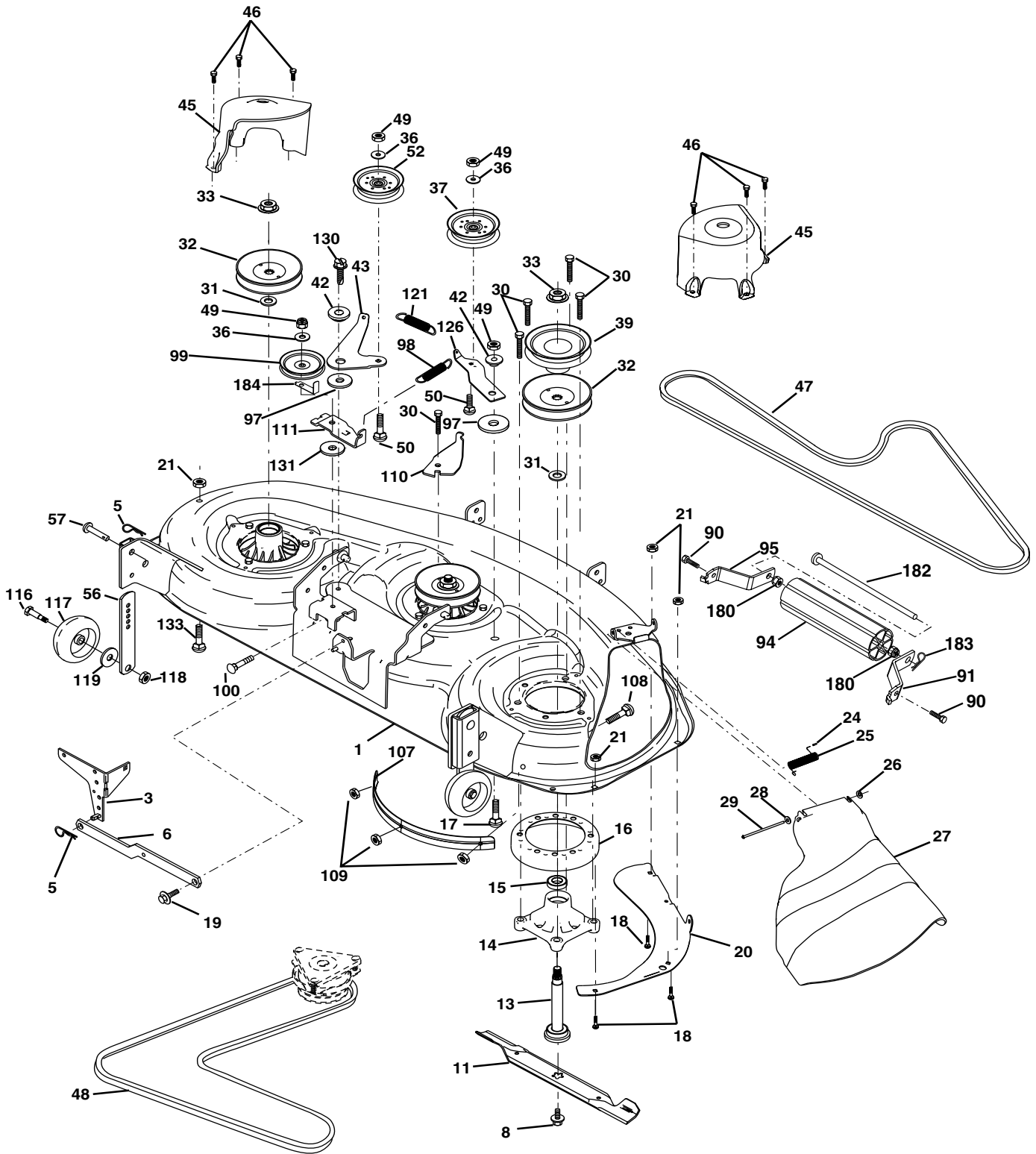

# REPAIR PARTS

TRACTOR - MODEL NO. 180H122 (PP18H122A), PRODUCT NO. 964 77 11-00  
MOWER DECK

KEY NO.	PART NO.	DESCRIPTION	KEY NO.	PART NO.	DESCRIPTION
1	532 18 03-59	Deck Weldment Mower 48	49	873 68 06-00	Nut, Crownlock 3/8-16 UNC
3	532 13 80-17	Bracket Asm., Sway Bar	50	872 11 06-12	Bolt, Carriage 3/8-16 x 1-1/2 Gr. 5
5	532 12 46-70	Retainer Spring	52	532 17 58-20	Pulley Idler Flat 46 Pri. Drive
6	532 17 80-24	Bar Sway Deck	56	532 15 59-86	Bar Pnt Adjusting Wheel Gauge
8	532 17 43-65	Bolt, 7/16 Asm. Blade	57	532 15 69-41	Pin Head Rivet
11	532 18 00-54	Blade	90	874 76 05-16	Bolt, Fin, Hex 5/16-18 x 1.0
13	532 17 51-47	Shaft Asm.	91	532 18 05-34	Bracket, Asm Noseroller, LH 48
14	532 17 43-58	Housing Mandrel 48"	94	532 17 60-66	Roller, Nose 48"
15	532 11 04-85	Bearing, Ball, Mandrel	95	532 18 05-35	Bracket, Asm Noseroller RH 48
16	532 17 44-93	Stripper, Mower	97	532 17 85-15	Washer Hardened
17	872 11 06-10	Bolt Rdhd Sq Neck 3/8-16 x 1.25	98	532 17 94-79	Spring Primary Drive
18	872 14 05-05	Bolt, Carriage 5/16-18 x 5/8	99	532 18 40-58	Pulley Idler "V"
19	532 13 28-27	Bolt, Hex Head, Shoulder 5/16-18	100	872 11 06-16	Bolt RDHD Sqnk 3/8-16 Unc x 2
20	532 17 43-78	Baffle, Vortex Mower	110	532 17 50-16	Arm Spring Secondary
21	873 68 05-00	Nut, Crownlock 5/16-18 UNC	111	532 17 46-10	Arm Spring Fixed Tension 48"
24	532 10 53-04	Cap, Sleeve	116	532 18 42-19	Bolt, Shoulder
25	532 17 81-02	Spring, Torsion	117	532 17 48-73	Gauge Wheel
26	532 11 04-52	Nut, Push	118	873 93 06-00	Nut, Centerlock 3/8-16 UNC
27	532 18 17-07	Shield, Deflector Mower	119	819 12 14-14	Washer 3/8 x 7/8 x 14 Ga.
28	819 11 10-16	Washer 11/32 x 5/8 x 16 Ga.	121	532 17 43-71	Spring Secondary Drive
29	532 13 14-91	Rod, Hinge	126	532 17 43-72	Arm, Idler, Primary Deck
30	532 17 39-84	Screw, Thdroll, Washer Head	130	817 00 06-16	Screw 3/8-16 x 1.0
31	532 12 99-63	Washer, Spacer Mower Vented	131	819 13 16-06	Washer 13/32 x 1 x 6 Ga.
32	532 17 78-65	Pulley, Mandrel	133	872 11 05-06	Bolt Rdhd Sqnk 5/16-18 x 3/4
33	532 17 83-42	Nut, Flg. Top Lock Cntr. 9/16	180	873 80 05-00	Nut Lock 5/16-18
36	819 13 13-16	Washer 13/32 x 13/16 x 16 Ga.	182	532 17 91-27	Rod Roller Nose
37	532 17 79-68	Pulley, Idler, Flat	183	532 16 35-52	Retainer Spring
39	532 17 43-75	Pulley, Idler, Driven	184	532 17 39-79	Keeper Belt Idler
42	532 16 57-23	Spacer, Retainer	--	532 18 17-04	Replacement Mower, Complete
43	532 17 43-73	Arm, Idler Secondary	--	532 17 43-57	Mandrel Assembly (Includes Housing, Shaft and Shaft Hardware Only-Pulley Not Included)
45	532 18 08-06	Cover, Mandrel Deck			
46	532 13 77-29	Screw, Thdroll. 1/4-20 x 5/8			
47	532 18 08-08	V-Belt, Mower, Secondary			
48	532 17 43-68	V-Belt, Mower, Primary			

**NOTE:** All component dimensions given in U.S. inches  
1 inch = 25.4 mm



# REPAIR PARTS

TRACTOR - MODEL NO. 180H122 (PP18H122A), PRODUCT NO. 964 77 11-00  
MOWER LIFT

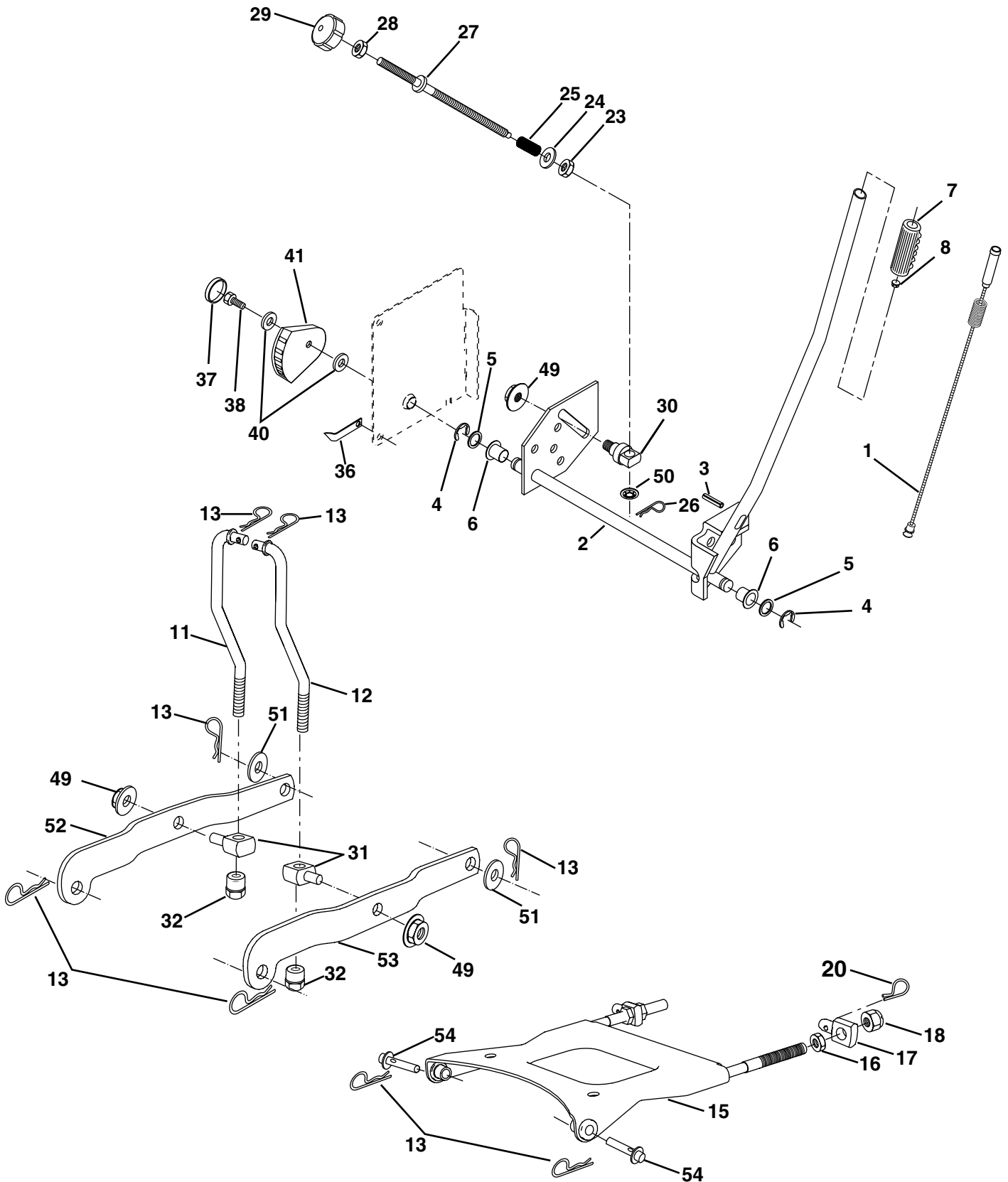

# REPAIR PARTS

TRACTOR - MODEL NO. 180H122 (PP18H122A), PRODUCT NO. 964 77 11-00  
MOWER LIFT

KEY NO.	PART NO.	DESCRIPTION
1	532 15 94-60	Wire Asm Inner/Spring W/Plunger LT
2	532 15 94-71	Shaft Asm Lift RH w/Inf
3	532 10 57-67	Pin Groove 1 500 Zinc
4	812 00 00-02	E Ring #5133-62
5	819 21 16-21	Washer 21/32 X 1 X 21 Ga
6	532 12 01-83	Bearing Nylon Blk 629 Id
7	532 12 56-31	Grip Handle Fluted Blk
8	532 17 07-70	Button Plunger
11	532 17 53-70	Link Lift LH
12	532 17 53-71	Link Lift RH
13	532 12 46-70	Retainer Spring
15	532 17 55-62	Plate Asm Susp Front
16	873 35 08-00	Nut Jam Hex 1/2-13 Unc
17	532 17 56-89	Trunnion
18	873 80 08-00	Nut Lock w/Wsh 1/2-13unc
20	532 16 35-52	Retainer Spring
23	532 11 08-07	Nut Special
24	819 13 10-16	Washer 13/32 X 5/8 X 16 Ga
25	532 12 48-74	Spring
26	532 16 94-84	Retainer Clip
27	532 12 69-71	Rod Adj Lift
28	873 35 06-00	Nut Hex Jam 3/8-16 Unc
29	532 13 80-57	Knob Inf 3/8-16 Unc Blk W/sym
30	532 15 02-33	Trunnion Infin Height
31	532 17 62-05	Trunnion
32	532 17 59-94	Nut Lift Link 7/16-20
36	532 15 50-97	Indicator Height STLT
37	532 12 39-35	Plug Hole Blk 1.485/1.515 Dia.
38	817 06 05-16	Screw 5/16-18 x 1
40	819 11 24-10	Washer 11/32 x 1-1/2 10 Ga.
41	532 15 50-98	Scale Ind. Height Blk.
49	532 14 52-12	Nut Hex Flange Lock
50	532 11 04-52	Nut, Push Phos & Oil
51	819 17 14-16	Washer 17/32 x 7/8 x 16 Ga.
52	532 17 53-78	Arm Susp. Rear Lh
53	532 17 58-02	Arm Susp. Rear Rh
54	532 17 55-60	Pin Flange

**NOTE:** All component dimensions given in U.S. inches  
1 inch = 25.4 mm