

ILLUSTRATED PARTS LIST

MFG ID NO. 96011019901

CUSTOMER CATALOG NO. P1197

PRODUCT NO. 960 11 01-99

**TRACTOR- -MODEL NO. P1197 (96011019901) PRODUCT NO. 960 11 01-99
DECALS**

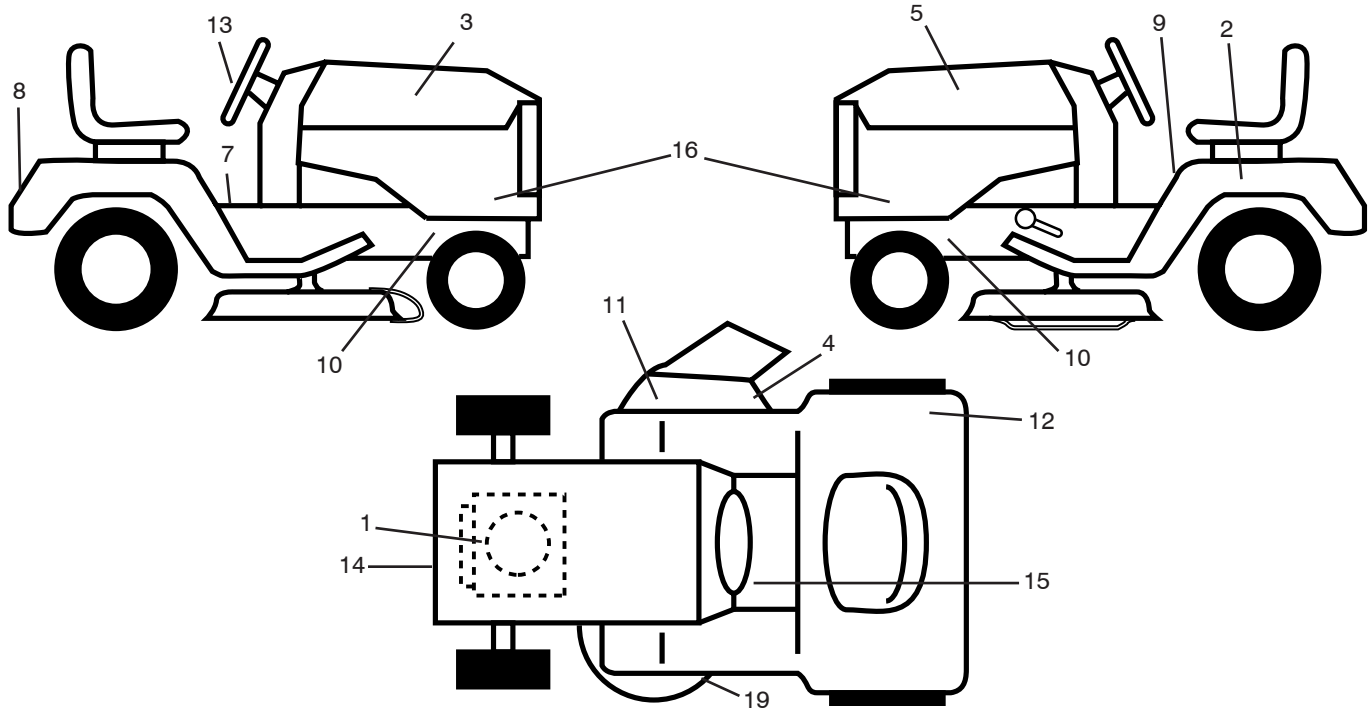

KEY NO.	PART NO.	DESCRIPTION
1	532 19 68-41	Decal, Warning Engine Symbols
2	532 14 50-05	Decal, Bat Dan/Poi P/L Symbols
3	532 19 44-90	Decal, Hood RH
4	532 19 63-57	Decal, Deflector Warning Symbols
5	532 19 44-91	Decal, Hood LH
7	532 14 08-37	Decal, Saddle Brake Parking
8	532 15 81-66	Decal, Fender Logo
9	532 40 03-89	Decal, Warning Sym. CE
10	532 15 97-36	Decal, Chassis Hot Muffler
11	532 18 21-66	Decal, Mower Cut finger Symbol

KEY NO.	PART NO.	DESCRIPTION
12	532 18 04-32	Decal, 100 DbA
13	532 18 97-05	Decal, Strg Wheel Cap
14	532 40 88-13	Decal, Eng. HP
15	532 15 97-37	Decal, Brake/Clutch
16	532 40 27-85	Decal, Hood
19	532 19 43-02	Decal, V-Belt Sch
--	532 41 16-58	Decal, Fender Warning
--	532 16 25-98	Decal, Drawbar Load Limit
--	532 13 83-11	Decal, Lift Handle (Lift Handle)
--	532 40 09-01	Manual Operator's Euro
--	532 40 09-02	Manual Operator's Scan

WHEELS & TIRES

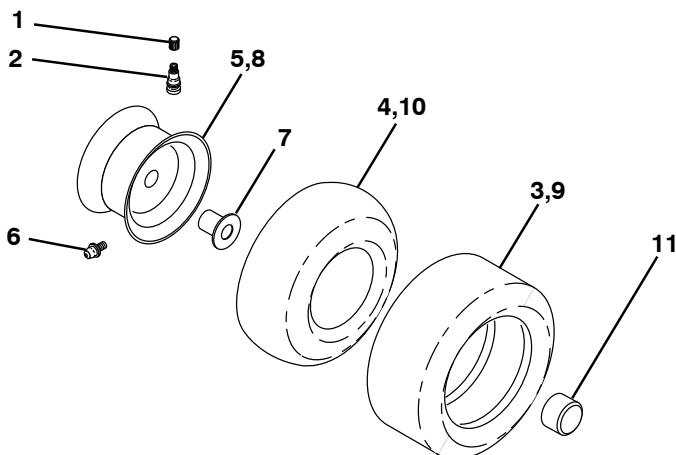

KEY NO.	PART NO.	DESCRIPTION
1	532 05 91-92	Cap Valve Tire
2	532 06 51-39	Stem Valve
3	532 12 41-57	Tire F Ts 15 x 6 - 6 Service
4	532 05 99-04	Tube Front (Service Item Only)
5	532 18 33-37	Rim Asm 6" Front Service
6	532 12 49-57	Fitting Grease (Front Wheel Only)
7	532 12 49-59	Bearing Flange (Front Wheel Only)
8	532 18 33-38	Rim Asm 8" Rear Service
9	532 12 39-69	Tire R Ts 18 x 8.5-8 C. Service
10	532 12 49-26	Tube Rear (Service Item Only)
11	532 17 50-39	Cap Axle Blk 1 50 x 1 00

NOTE: All component dimensions given in U.S. inches
1 inch = 25.4 mm

TRACTOR- -MODEL NO. P1197 (96011019901) PRODUCT NO. 960 11 01-99 SCHEMATIC

03059_197428

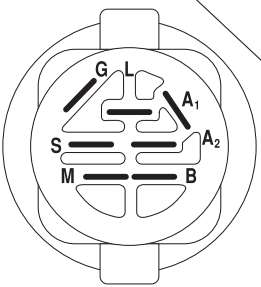
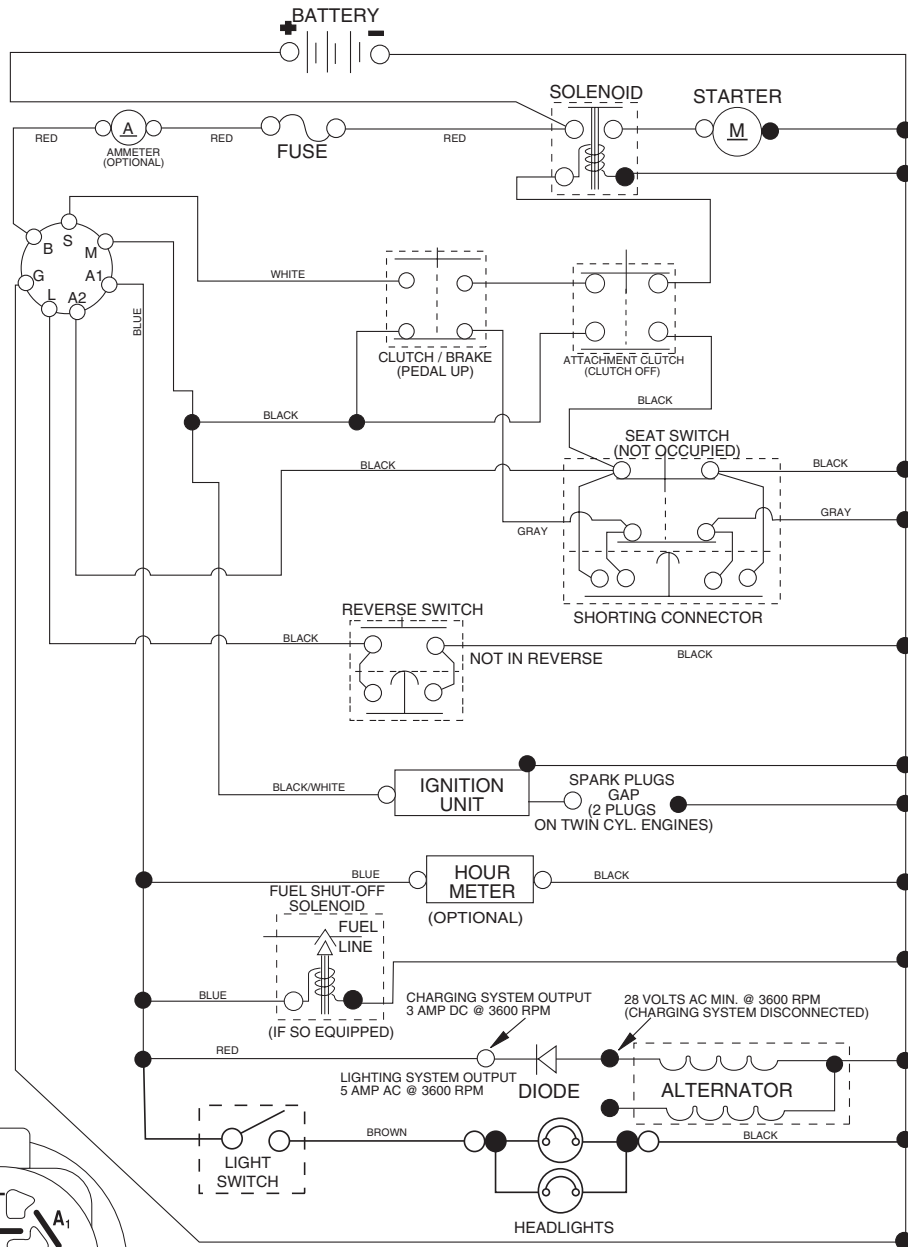

IGNITION SWITCH

POSITION	CIRCUIT	"MAKE"
OFF	M+G+A1	
RUN/OVERRIDE	B+A1	
RUN	B+A1	L+A2
START	B + S + A1	

03059

NOTE

YOUR TRACTOR IS EQUIPPED WITH A SPECIAL ALTERNATOR SYSTEM. THE LIGHTS ARE NOT CONNECTED TO THE BATTERY, BUT HAVE THEIR OWN ELECTRICAL SOURCE. BECAUSE OF THIS, THE BRIGHTNESS OF THE LIGHTS WILL CHANGE WITH ENGINE SPEED. AT IDLE THE LIGHTS WILL DIM. AS THE ENGINE IS SPEEDED UP, THE LIGHTS WILL BECOME THEIR BRIGHTEST.

●
NON-REMOVABLE CONNECTIONS

○
REMOVABLE CONNECTIONS

WIRING INSULATED CLIPS

NOTE: IF WIRING INSULATED CLIPS WERE REMOVED FOR SERVICING OF UNIT, THEY SHOULD BE REPLACED TO PROPERLY SECURE YOUR WIRING.

**TRACTOR- -MODEL NO. P1197 (96011019901) PRODUCT NO. 960 11 01-99
ELECTRICAL**

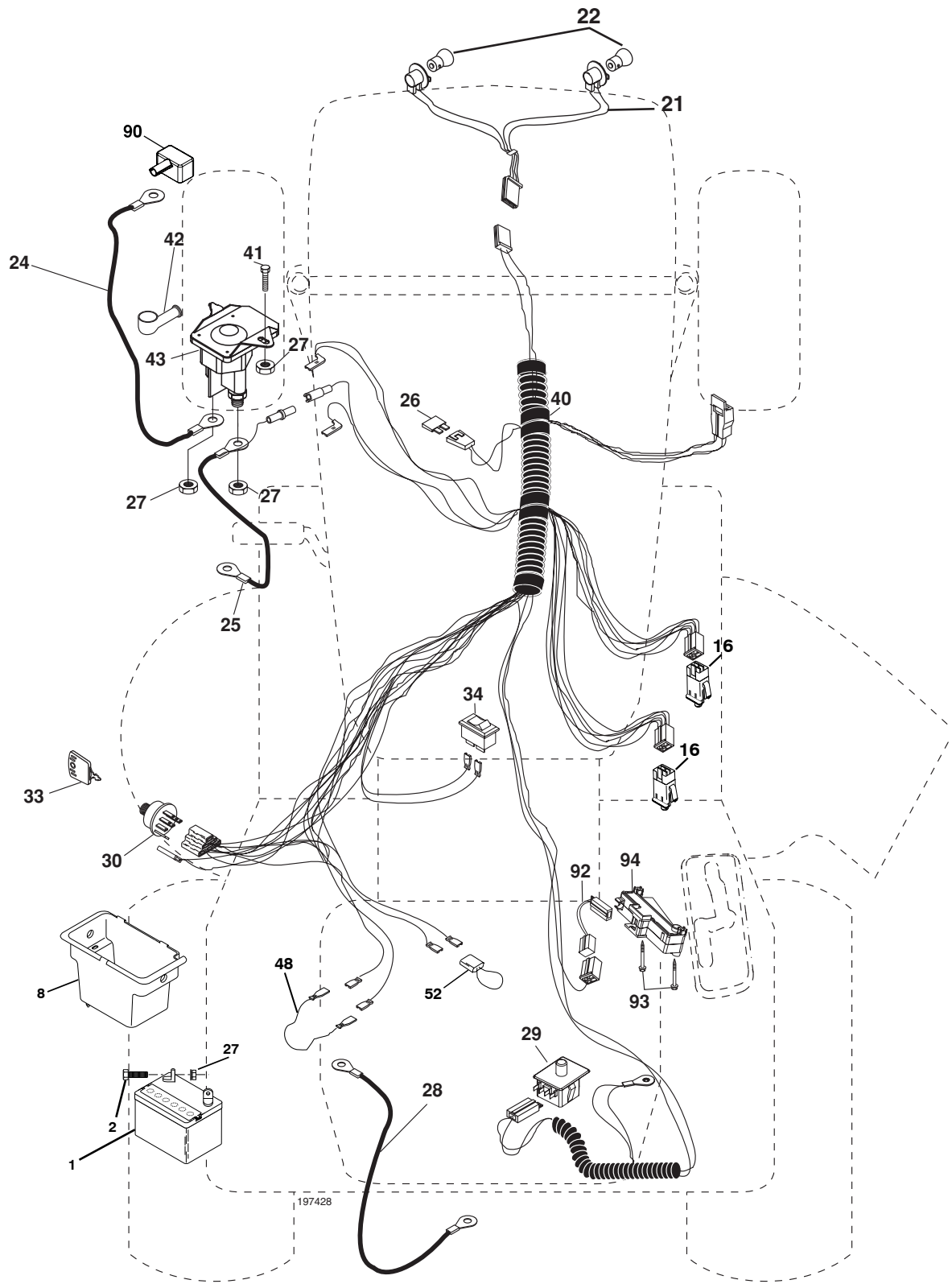

**TRACTOR- -MODEL NO. P1197 (96011019901) PRODUCT NO. 960 11 01-99
ELECTRICAL**

KEY NO.	PART NO.	DESCRIPTION
1	532 16 34-65	Battery
2	874 76 04-12	Bolt Hex Hd 1/4-20 unc x 3/4
8	532 17 66-89	Box Battery Fender
16	532 17 61-38	Switch Interlock
21	532 18 37-59	Harness Headlight
22	532 00 41-52	Bulb
24	532 12 47-80	Cable Battery 6 Ga 11" Red
25	532 14 61-47	Cable Battery 6 Ga Red w/16 wire
26	532 17 51-58	Fuse
27	873 51 04-00	Nut Keps Hex 1/4-20 unc
28	532 12 47-73	Cable Ground 6 Ga 12" Black
29	532 19 27-49	Switch Seat
30	532 19 33-50	Switch Ignition
33	532 14 04-01	Key
34	532 11 07-12	Switch Light/Reset
40	532 19 74-28	Harness Ignition
41	871 11 04-08	Bolt Blk Fin Hex 1/4 - 20 x 1/2
42	532 13 15-63	Cover Terminal Red
43	532 19 25-07	Solenoid
48	532 14 08-44	Adapter Ammeter Rectangular
52	532 14 19-40	Protection Wire Loop
90	532 18 04-49	Cover Terminal Battery
92	532 19 66-15	Harness Pigtail Console ROS
93	532 19 25-40	Screw Plastite 10-14 x 2.0
94	532 19 18-34	Module Reverse ROS

NOTE: All component dimensions given in U.S. inches.
1 inch = 25.4 mm.

TRACTOR- -MODEL NO. P1197 (96011019901) PRODUCT NO. 960 11 01-99 CHASSIS

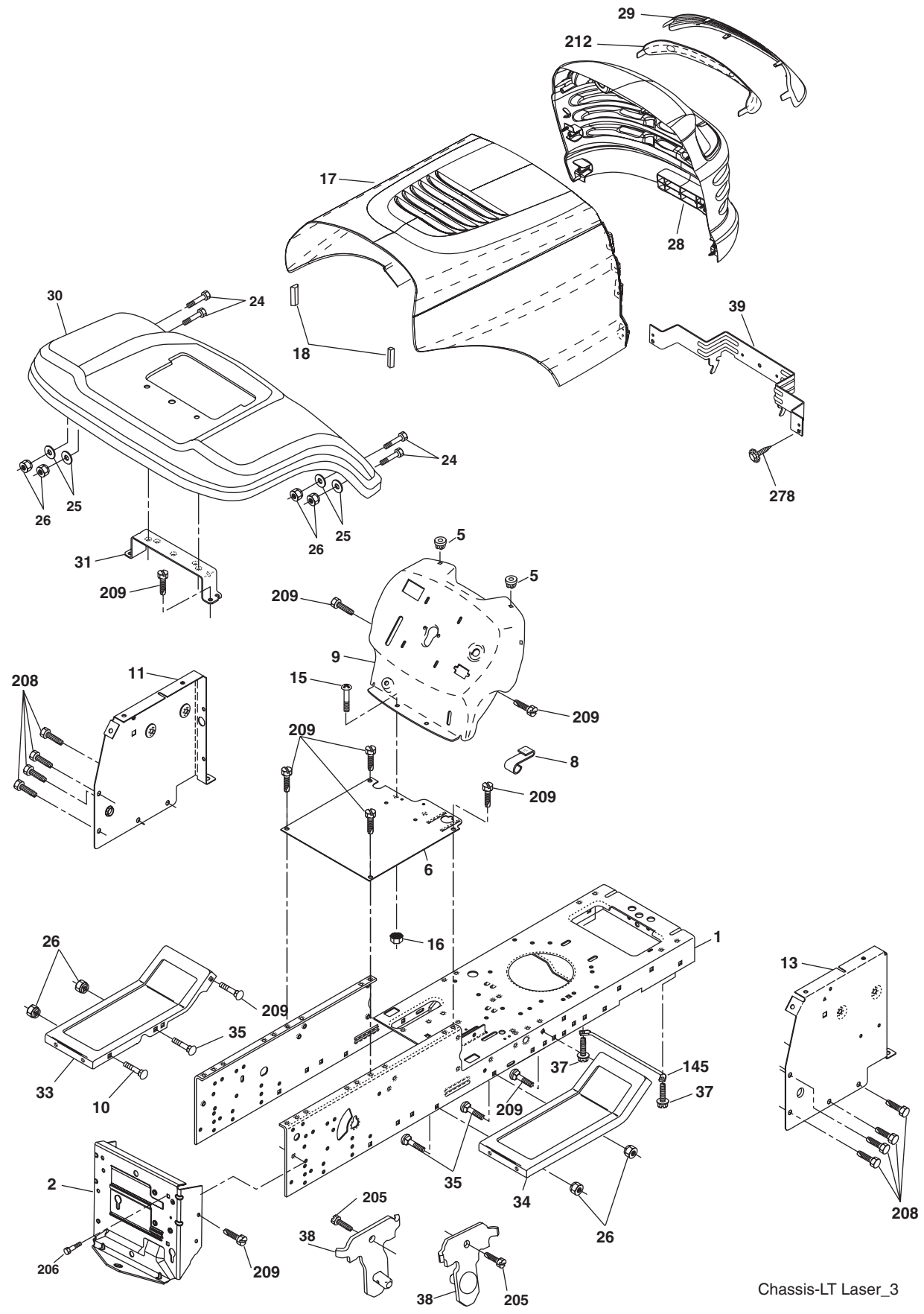

Chassis-LT Laser_3

**TRACTOR- -MODEL NO. P1197 (96011019901) PRODUCT NO. 960 11 01-99
CHASSIS**

KEY NO.	PART NO.	DESCRIPTION
1	532 17 46-20	Chassis
2	532 17 65-54	Drawbar
5	532 15 52-72	BumperHood/Dash
6	532 18 44-19	Saddle
8	532 15 51-38	Clip, Retainer Slide-On
9	532 19 35-18	Dash
10	872 14 06-08	Bolt, Carriage 3/8-16 x 1
11	532 17 49-96	Dashboard, Panel LH
13	532 17 51-49	Dashboard, Panel RH
15	874 18 05-12	Machine Screw 5/16-18 unc x 3/4
16	873 51 05-00	Nut, Keps 5/16-18 unc
17	532 18 27-16	Hood Pnt
18	532 18 49-21	BumperHood
24	874 78 06-16	Bolt, Hex Head, Fin. 3/8-16 x 1 Gr. 5
25	819 13 13-12	Washer 13/32 x 13/16 x12 Ga.
26	873 80 06-00	Nut Lock Hex w/Ins. 3/8-16 unc
28	532 17 97-49	Grille (Includes Key Nos. 29, 212)
29	532 18 27-18	Lens
30	532 40 48-52	Fender
31	532 13 66-19	Fender Bracket
33	532 18 25-07	Footrest, LH
34	532 18 25-08	Footrest, RH
35	872 11 06-06	Bolt 3/8-16 X 3/4
37	817 49 05-08	Screw Thdrol 5/16-18 x 1/2
38	532 17 57-10	Bracket Asm. Pivot Mower Rear
39	532 40 78-07	Bracket Pivot Laser/Elite
145	532 40 91-67	Rod Pivot Chassis/Hood
205	817 49 06-08	Screw Thdrol 3/8-16 x 1/2
206	532 17 01-65	Bolt Shoulder 5/16-18 TT
208	817 67 06-08	Screw Thdrol 3/8-16 x 1/2
209	817 00 06-12	Screw Hexwsh Thdr 3/8-16 x 3/4
212	532 17 51-43	Insert Lens Reflective
278	532 19 16-11	Screw 10 x 3/4 Single Lead-Hex
--	532 00 54-79	Button Plug

NOTE: All component dimensions given in U.S. inches.
1 inch = 25.4 mm.

TRACTOR- -MODEL NO. P1197 (96011019901) PRODUCT NO. 960 11 01-99
DRIVE

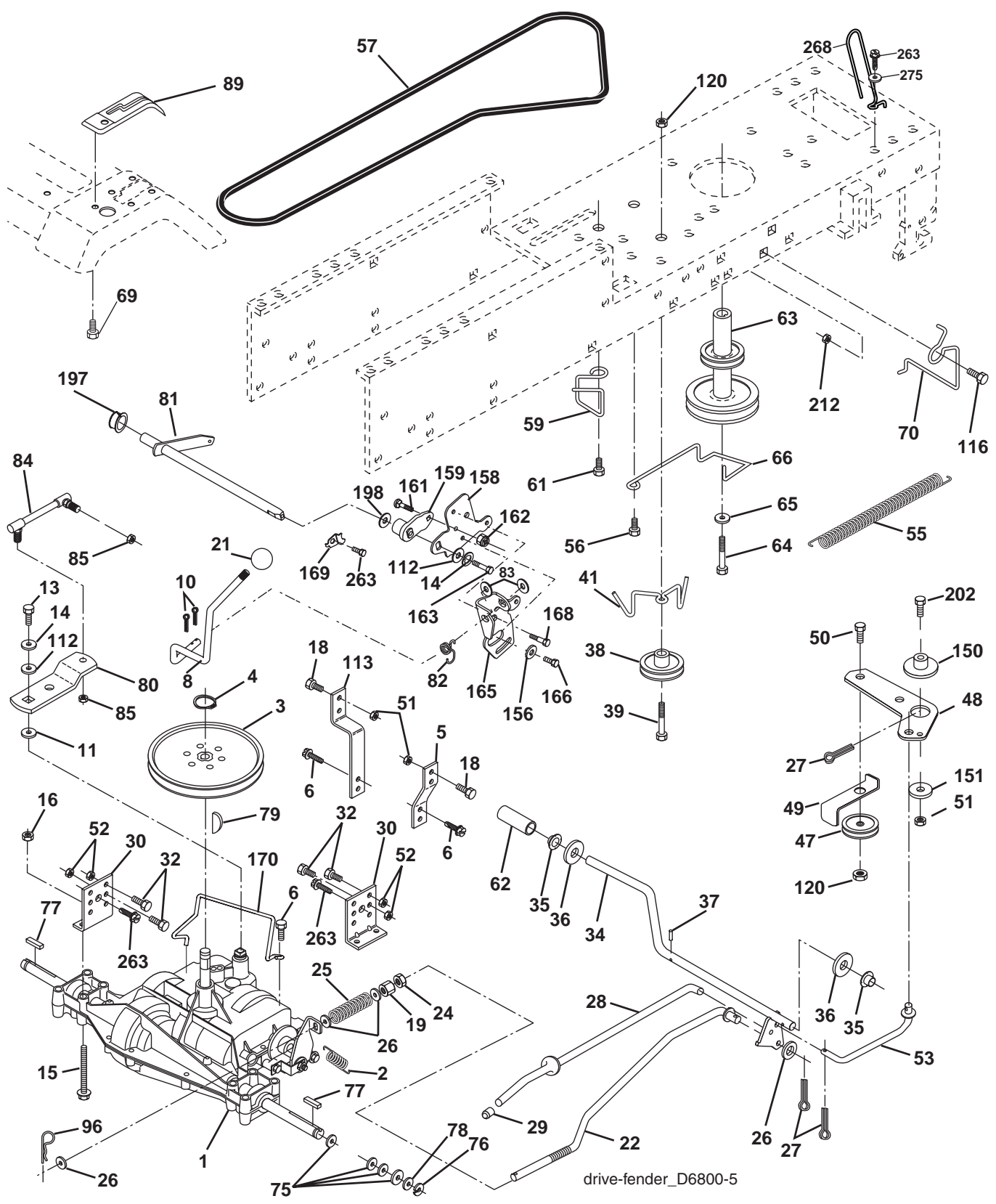

drive-fender_D6800-5

**TRACTOR- -MODEL NO. P1197 (96011019901) PRODUCT NO. 960 11 01-99
DRIVE**

KEY NO.	PART NO.	DESCRIPTION	KEY NO.	PART NO.	DESCRIPTION
1	-----	Transaxle, Dana D6800 (Order parts from transaxle manufacturer)	61	817 12 06-14	Screw 3/8-16 x .875
2	532 14 66-82	Spring Return Brake T/a Zinc	62	532 12 48-72	Cover Pedal Blk Round
3	532 12 36-66	Pulley Transaxle 18" tires	63	532 17 54-10	Engine Pulley
4	812 00 00-28	Ring Retainer # 5100-62	64	532 17 39-37	Bolt Hex
5	532 12 15-20	Strap Torque 30 Degrees	65	810 04 07-00	Washer Lock Hvy Hlcl Spr 7/16
6	817 06 05-12	Screw 5/16-18 x 3/4	66	532 15 47-78	Keeper Belt Engine Foolproof
8	532 19 27-06	Rod Shifter	69	532 14 24-32	Screw Hex Wsh Hi-Lo 1/4 x 1/2 unc
10	876 02 04-16	Pin Cotter 1/8 x 1 Cad	70	532 13 46-83	Guide Belt Mower Drive RH
11	532 10 57-01	Washer Plate Shf 388 Sq Hole	75	532 12 17-49	Washer 25/32 x 1 1/4 x 16 Ga
13	874 55 04-12	Bolt 1/4-28 Unf Gr. 8 W/Patch	76	812 00 00-01	E-ring #5133-75
14	810 04 04-00	Washer Lock Hvy Helical 1/4	77	532 12 35-83	Key Square 2 0 x 1845/ 1865
15	874 49 05-44	Bolt Hex Flghd 5/16-18 Gr. 5	78	532 12 17-48	Washer 25/32 x 1-5/8 x 16 Ga
16	873 80 05-00	Nut Lock Hx W/Ins 5/16-18 unc	79	532 12 50-96	Key Woodruff
18	874 78 06-16	Bolt, Fin Hex 3/8-16 Unc x 1 Gr. 5	80	532 13 14-88	Arm Shift Transaxle
19	873 80 06-00	Nut Lock 3/8-16 unc	81	532 16 55-94	Shaft Asm. Cross Taper
21	532 10 69-33	Knob	82	532 16 57-11	Spring Torsion Shift
22	532 13 08-04	Rod Brake	83	819 17 12-16	Washer 17/32 x 3/4 x 16 Ga.
24	873 35 06-00	Nut Hex Jam 3/8-16 unc	84	532 16 62-29	Link Transaxle
25	532 10 68-88	Spring Rod Brake 2 00 Zinc	85	532 15 03-60	Nut Lock Center 1/4-28
26	819 13 13-16	Washer 13/32 x 13/16 x 16 Ga	89	532 19 75-15	Console Asm
27	876 02 04-12	Pin Cotter 1/8 x 3/4 Cad	96	532 12 47-88	Retainer Spring 1"
28	532 17 57-65	Rod Brake Parking	112	819 09 12-10	Washer 9/32 x 3/4 x 10 Ga.
29	532 07 16-73	Cap Brake Parking	113	532 12 72-85	Strap Torque Lh
30	532 17 49-73	Bracket Mtg Transaxle	116	872 14 06-08	Bolt Rdhd Sq Neck 3/8-16 x 1.00
32	874 76 05-12	Bolt Hex Hd 5/16-18 unc x 3/4	120	873 90 06-00	Nut Lock Flg 3/8-16
34	532 17 55-78	Shaft Asm Pedal Foot	150	532 17 54-56	Spacer Retainer
35	532 12 01-83	Bearing Nylon Blk 629 Id	151	819 13 32-10	Washer 13/32 x 2 x 10
36	819 21 16-16	Washer 21/32 x 1 x 16 Ga	156	532 16 60-02	Washer Srrtd 5/16 ID x 1.0 x .125TK
37	532 12 49-63	Pin Roll 3/16 x 1"	158	532 16 55-89	Bracket Shift Mount
38	532 17 91-14	Pulley Idler Composite	159	532 18 39-00	Hub Shift
39	872 11 06-22	Bolt Rdhd 3/8-16 unc x 2-3/4 Gr. 5	161	872 14 04-06	Bolt RDHD SQNK 1/4-20 x 3/4 Gr. 5
41	532 17 55-56	Keeper Belt Retainer Idler	162	873 68 04-00	Nut Crownlock 1/4-20 unc
47	532 12 77-83	Pulley Idler V Groove Plastic	163	874 78 04-16	Bolt Hex Fin 1/4-20 unc x 1 Gr. 5
48	532 15 44-07	Bellcrank Asm	165	532 16 56-23	Bracket Pivot Lever
49	532 12 32-05	Retainer Belt Style Spring	166	817 49 05-10	Screw 5/16-18 x 5/8 TT Yellow
50	872 11 06-12	Bolt Carr Sh 3/8-16 x 1-1/2 Gr. 5	168	532 16 54-92	Shoulder Bolt 5/16 -18 x .561
51	873 68 06-00	Nut Crownlock 3/8-16 unc	169	532 16 55-81	Plate Fastening
52	873 68 05-00	Nut Crownlock 5/16-18 unc	170	532 18 74-14	Keeper Belt T/A
53	532 19 96-52	Link Clutch	197	532 16 96-13	Nyliner Snap-in 5/8" ID
55	532 10 57-09	Spring Return Clutch 6 75	198	532 16 98-45	Washer Nyl
56	817 06 06-20	Screw 3/8-16 x 1-1/4	202	872 11 06-14	Bolt, 3/8 - 16 x 1-3/4 Gr. 5
57	532 40 16-03	V-Belt Traction Drive	212	532 14 52-12	Nut Flange Hex Lock
59	532 16 96-91	Keeper Belt Span Ctr	263	817 00 06-12	Screw 3/8-16 x 3/4
			268	532 18 24-02	Guard Muffler
			275	819 13 16-14	Washer 13/32 x 1 x 14 Ga.

NOTE: All component dimensions given in U.S. inches
1 inch = 25.4 mm

TRACTOR- -MODEL NO. P1197 (96011019901) PRODUCT NO. 960 11 01-99
MOWER

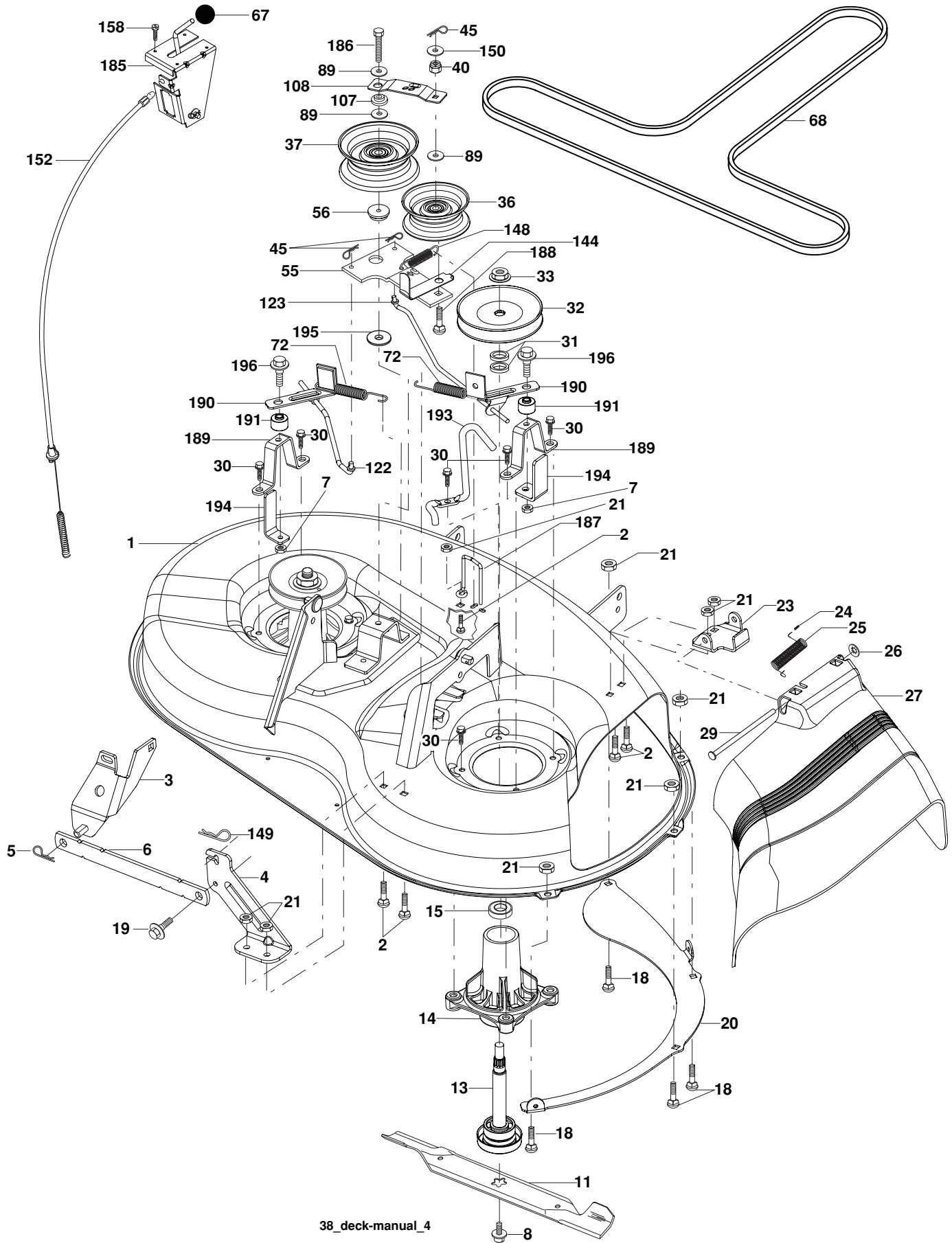

38_deck-manual_4

**TRACTOR- -MODEL NO. P1197 (96011019901) PRODUCT NO. 960 11 01-99
MOWER**

KEY NO.	PART NO.	DESCRIPTION	KEY NO.	PART NO.	DESCRIPTION
1	532 19 25-56	Mower Housing Assembly	67	532 10 69-32	Knob
2	872 14 05-06	Bolt Carriage 5/16-18 x 3/4	68	532 19 32-14	V-Belt
3	532 13 80-17	Bracket Asm Fr. Sway Bar	72	532 19 32-16	Spring Brake Return
4	532 19 25-68	Bracket Deck Sway Bar 38"/42"	89	819 13 13-11	Washer 13/32 x 13/16 x 11 Ga.
5	532 12 46-70	Retainer Spring	107	532 13 35-02	Spacer Retainer
6	532 17 80-24	Bar Sway Deck	108	532 13 35-03	Stiffener, Idler Arm
7	873 80 05-00	Nut Lock Hx W/INs. 5/16-18 unc	122	532 41 01-89	Link, Brake LH
8	532 19 30-03	Bolt 3/8-24 x 1.25 Gr. 8	123	532 41 01-90	Link, Brake RH
11	532 19 39-57	Blade Mower	144	532 19 34-14	Keeper Belt Idler Tension
13	532 19 28-72	Shaft Assembly, Mandrel, Vented	148	532 16 90-22	Spring Return Idler
14	532 18 72-81	Housing, Mandrel, Vented	149	532 16 58-98	Retainer Spring Yellow
15	532 11 04-85	Bearing, Ball, Mandrel	150	819 09 12-10	Washer 9/32 x 3/4 x 10 Ga.
18	872 14 05-05	Bolt Rdhd Sqnk 5/16-18 x 5/8	152	532 19 32-35	Clutch Cable 38"/46"
19	532 13 28-27	Bolt, Shoulder	158	817 72 04-08	Screw Hex Thd Cut 1/4-20 x 1/2
20	532 40 00-95	Baffle Vortex Front	185	532 18 82-34	Head Asm Cable Clutch
21	873 68 05-00	Nut	186	817 49 06-44	Screw Hex Wsh Thdrol 3/8-16 x 2-3/4
23	532 19 25-57	Bracket, Mower Deflector	187	532 19 34-12	Keeper Belt
24	532 10 53-04	Cap, Sleeve	188	532 16 58-91	Bolt Carriage Idler
25	532 19 70-26	Spring, Torsion, Deflector	189	532 19 25-59	Stand, Brake
26	532 11 04-52	Nut, Push	190	532 19 25-60	Arm, Brake
27	532 40 14-72	Shield, Deflector	191	532 19 25-61	Spacer, Brake
29	532 13 14-91	Rod, Hinge	193	532 19 34-13	Keeper Belt Rh Mandrel
30	532 17 39-84	Screw Thdrol	194	532 19 41-05	Guard Brake
31	532 18 76-90	Washer, Spacer	195	819 13 32-10	Washer
32	532 15 35-32	Pulley, Mandrel	196	532 19 37-82	Bolt/Washer Asm 5/16-18
33	532 40 02-34	Nut, Toplock	--	532 19 25-58	Brake Assembly (Includes Stand, Arm and Guard Components)
36	532 13 14-94	Pulley, Idler, Flat	--	532 19 28-70	Mandrel Assembly (Includes Housing, Shaft and Shaft Hardware Only - Pulley Not Included)
37	532 19 31-98	Pulley Idler Flat	--	532 19 36-46	Replacement Mower, Complete
40	873 68 06-00	Nut, Crownlock 3/8-16 unc			
45	532 12 47-88	Retainer			
55	532 13 38-40	Idler Arm Assembly			
56	532 16 57-23	Spacer, Retainer, Mower			

NOTE: All component dimensions given in U.S. inches
1 inch = 25.4 mm

**TRACTOR- -MODEL NO. P1197 (96011019901) PRODUCT NO. 960 11 01-99
ENIGNE**

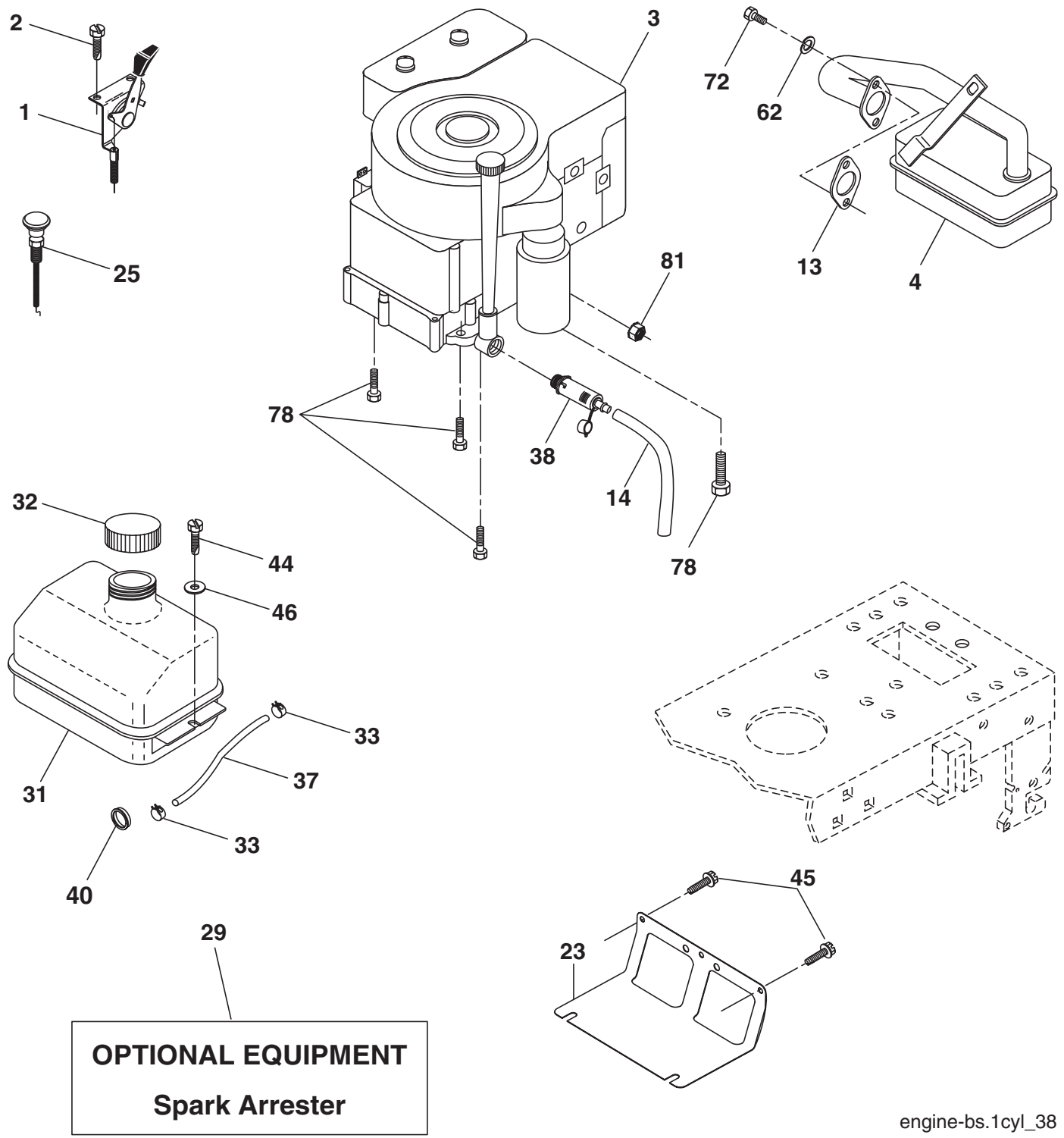

engine-bs.1cyl_38

**TRACTOR- -MODEL NO. P1197 (96011019901) PRODUCT NO. 960 11 01-99
ENIGNE**

KEY NO.	PART NO.	DESCRIPTION
1	532 17 05-51	Control Th/ch Flag
2	817 72 04-08	Screw Hex Thd Cut 1/4-20 x 1/2
3	-----	Engine B&S Model No. 219807 (Order parts from engine manufacturer)
4	532 17 97-58	Muffler
13	532 16 52-91	Gasket Eng
14	532 14 84-56	Tube Drain Oil Easy
23	532 16 98-37	Shield Brn/Dbr Guard
25	532 19 06-95	Control Choke
29	532 13 71-80	Kit Spark Arrester
31	532 40 75-16	Tank Fuel Front 1.25
32	532 19 77-25	Cap Asm Fuel Top
33	532 12 34-87	Clamp Hose Blk
37	532 13 70-40	Line Fuel 20"
38	532 18 16-54	Plug Oil Drain Easy
40	532 12 40-28	Bushing Snap Nyl Blk Fuel Line
44	817 67 04-12	Screw Hexwsh Thdrol 1/4-20 x 3/4
45	817 00 06-12	Screw Hexwsh Thdrol 3/8-16 x 3/4
46	819 09 14-16	Washer 9/32 x 7/8 x 16 Ga.
62	810 04 05-00	Washer Lock 5/16
72	532 19 23-34	Screw Socket HD 5/16-18 x .75
78	817 06 06-20	Screw 3/8-16 x 1-1/4
81	873 51 04-00	Nut Keps Hex 1/4-20 unc

NOTE: All component dimensions given in U.S. inches
1 inch = 25.4 mm

Engine Power Rating Information

The gross power rating for individual gas engine models is labeled in accordance with SAE (Society of Automotive Engineers) code J11940 (Small Engine Power & Torque Rating Procedure), and rating performance has been obtained and corrected in accordance with SAE J1995 (Revision 2002-5). Actual gross engine power will be lower and is affected by, among other things, ambient operating conditions and engine-to-engine variability. Given both the wide array of products on which engines are placed and the variety of environmental issues applicable to operating the equipment, the gas engine will not develop the rated gross power when used in a given piece of power equipment (actual "on-site" or net horsepower). This difference is due to a variety of factors including, but not limited to, accessories (air cleaner, exhaust, charging, cooling, carburetor, fuel pump, etc.), application limitations, ambient operating conditions (temperature, humidity, altitude), and engine-to-engine variability. Due to manufacturing and capacity limitations, Briggs & Stratton may substitute an engine of higher rated power for this Series engine.

TRACTOR- -MODEL NO. P1197 (96011019901) PRODUCT NO. 960 11 01-99
STEERING ASSEMBLY

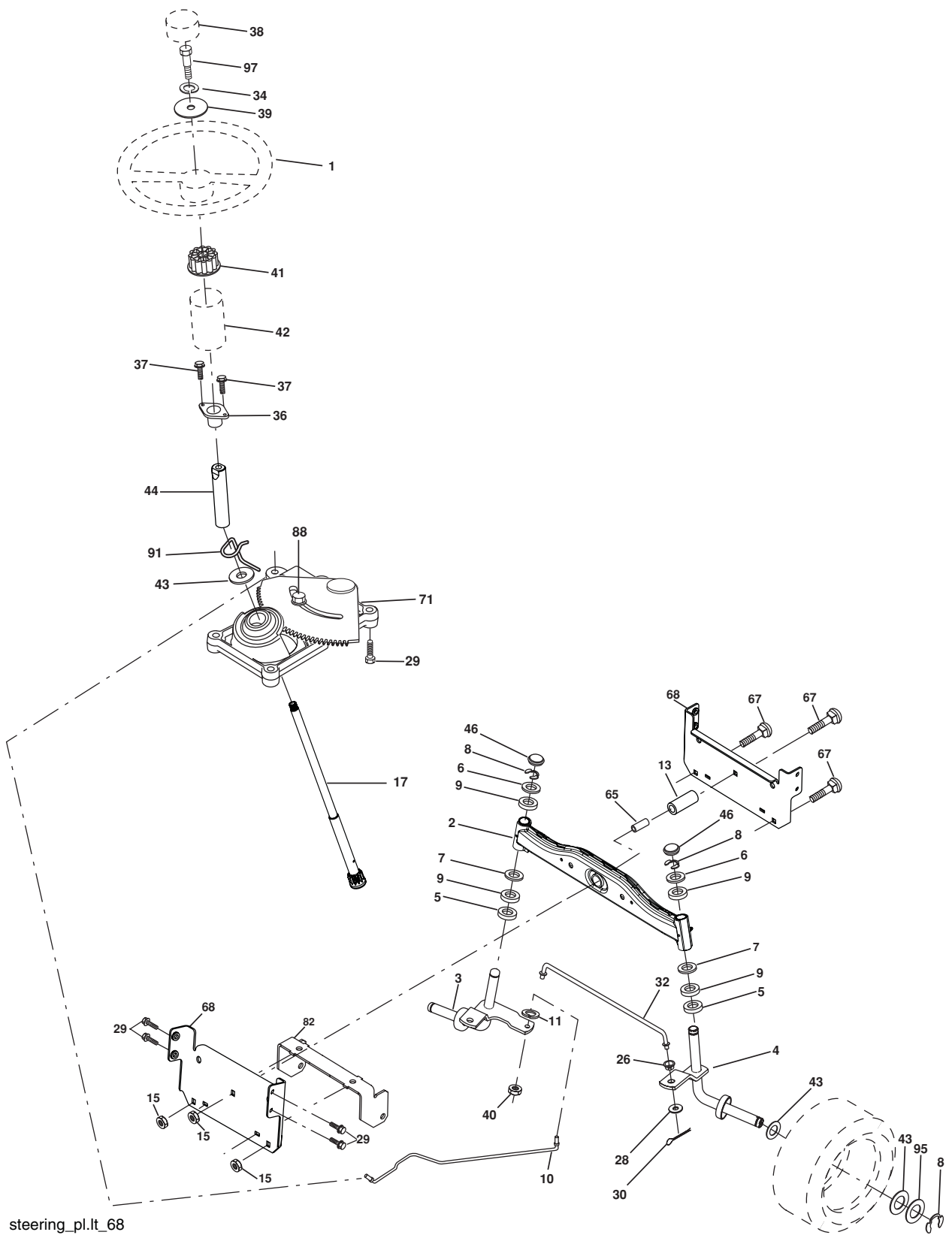

steering_pl.it_68

**TRACTOR- -MODEL NO. P1197 (96011019901) PRODUCT NO. 960 11 01-99
STEERING ASSEMBLY**

KEY NO.	PART NO.	DESCRIPTION
1	532 18 67-80	Wheel Steering Opp. Sears Blk
2	532 19 56-73	Axle Asm
3	532 16 98-40	Spindle Asm LH
4	532 16 98-39	Spindle Asm RH
5	532 12 49-31	Washer Thrust .75 x 1.230
6	532 12 17-48	Washer 25/32 x 1-5/8 x 16 Ga.
7	819 27 20-16	Washer 27/32 x 1-1/4 x 16 Ga.
8	812 00 00-29	Ring Klip #t5304-75
9	532 12 49-37	Bearing Col Strg Blk
10	532 17 51-21	Link Drag
11	810 04 06-00	Washer Lock Hvy Hlcl Spr 3/8
13	532 13 65-18	Spacer Brace Axle
15	532 14 52-12	Nut Hexflange Lock
17	532 19 07-53	Shaft Asm Strg
26	532 12 68-47	Bushing Link Drag Blk LR
28	819 13 14-16	Washer 13/32 x 7/8 x 16 Ga.
29	817 00 06-12	Screw 3/8-16 x .75
30	876 02 04-12	Pin Cotter 1/8 x 3/4 Cad
32	532 19 27-57	Rod Tie Wire Form 19 75 Mech
34	810 04 05-00	Washer Lock Hvy Hlcl Spr. 5/16
36	532 15 50-99	Bushing Strg Nat .623/.618ld
37	532 15 29-27	Screw TT #10-32 x 5 x 3/8 Flange
38	532 19 29-16	Cap Wheel Steer P/L
39	819 11 38-12	Washer 11/32 x 2-3/8
40	873 54 06-00	Nut Crownlock 3/8-24
41	532 18 67-37	Adaptor Wheel Strg
42	532 16 96-33	Boot Shaft Steering
43	532 12 17-49	Washer 25/32 x 1-1/4 x 16 Ga.
44	532 19 07-52	Extension Steering
46	532 12 12-32	Cap Spindle Fr Top Blk
65	532 16 03-67	Spacer Brace Axle
67	872 11 06-18	Bolt RDHD SQ 3/8-16 unc x 2-1/4
68	532 16 98-27	Brace Axle
71	532 17 51-46	Steering Asm
82	532 19 99-78	Bracket Susp. Chassis Front
88	532 17 51-18	Bolt Shoulder 7/16-20
91	532 17 55-53	Clip Steering
95	532 18 89-67	Washer Hardened
97	874 78 05-64	Bolt 5/16-18 unc x 4" L Gr. 5

NOTE: All component dimensions given in U.S. inches.
1 inch = 25.4 mm.

**TRACTOR- -MODEL NO. P1197 (96011019901) PRODUCT NO. 960 11 01-99
SEAT ASSEMBLY**

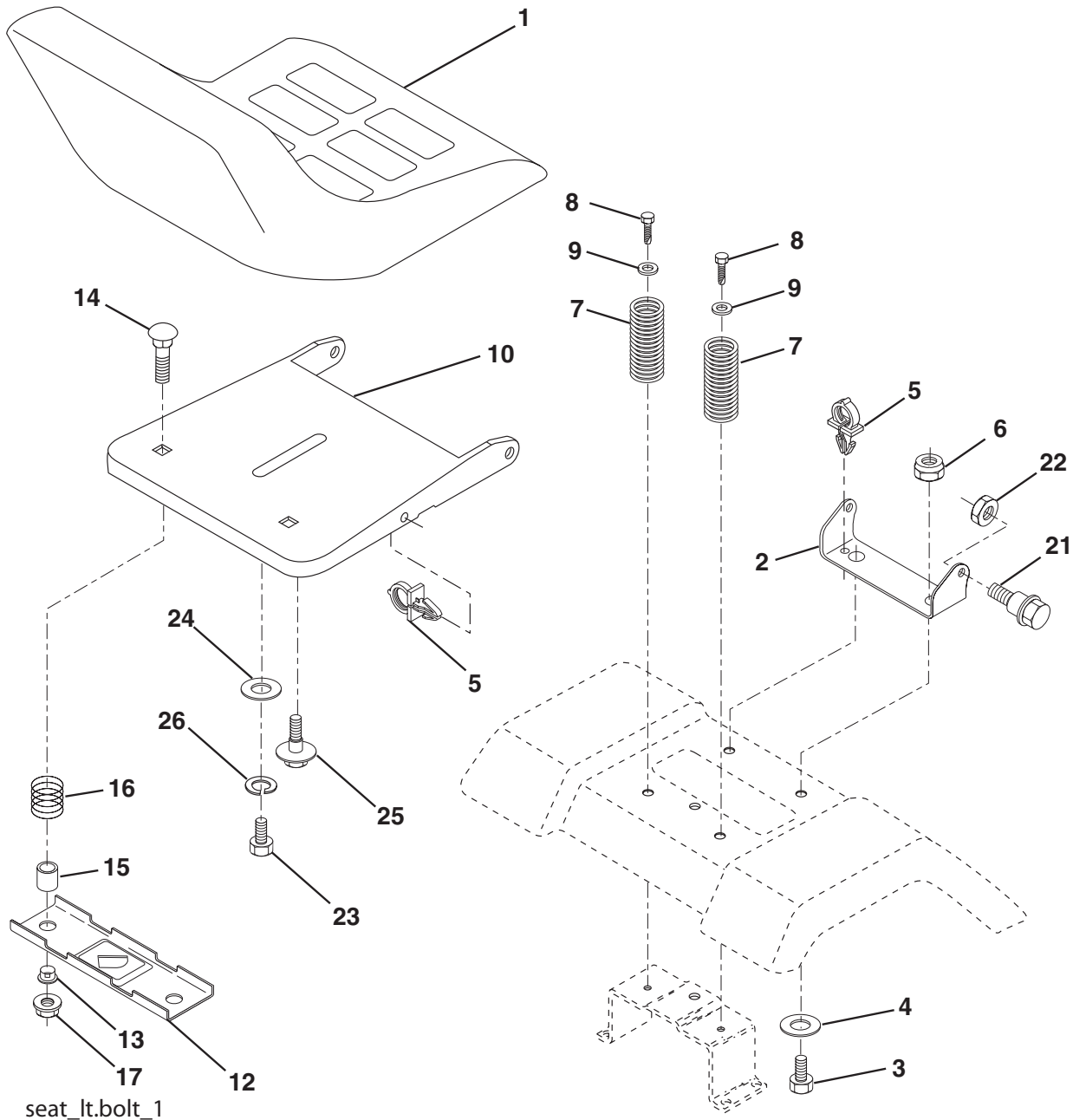

KEY NO.	PART NO.	DESCRIPTION
1	532 40 10-42	Seat
2	532 14 05-51	Bracket Pivot Seat
3	871 11 06-16	Bolt Fin Hex 3/8-16 unc x 1
4	819 13 16-10	Washer 13/32 x 1 x 10 Ga
5	532 14 50-06	Clip Push-In
6	873 80 06-00	Nut Lock Hex w/Wsh 3/8-16 unc
7	532 12 41-81	Spring Seat Cprsn 2 250 Blk Zi
8	817 00 06-16	Screw 3/8-16 x 1.5
9	819 13 16-14	Washer 13/32 x 1 x 14 Ga.
10	532 19 55-30	Pan Seat
12	532 17 46-48	Bracket Mounting Switch

KEY NO.	PART NO.	DESCRIPTION
13	532 12 12-48	Bushing Snap Blk Nyl 50 Id
14	872 05 04-12	Bolt Rdhd Sht Nk 1/4-20 x 1-1/2
15	532 13 43-00	Spacer Split 28 x 96 Yel Zinc
16	532 12 12-50	Spring Cprsn 1 27 Blk Pnt
17	532 12 39-76	Nut Lock 1/4 Lge Flg Gr 5 Zinc
21	532 17 18-52	Bolt Shoulder 5/16-18 unc -2A
22	873 80 05-00	Nut Lock Hex W/Insert 5/16-18 unc
23	871 11 08-14	Bolt Hex
24	819 17 19-12	Washer 17/32 x 1-3/16 x 12 Ga.
25	532 12 70-18	Bolt Shoulder 5/16-18 x 62
26	810 04 08-00	Washer Lock Hvy HLCLSPR 1/2

NOTE: All component dimensions given in U.S. inches.
1 inch = 25.4 mm

**TRACTOR- -MODEL NO. P1197 (96011019901) PRODUCT NO. 960 11 01-99
MOWER LIFT**

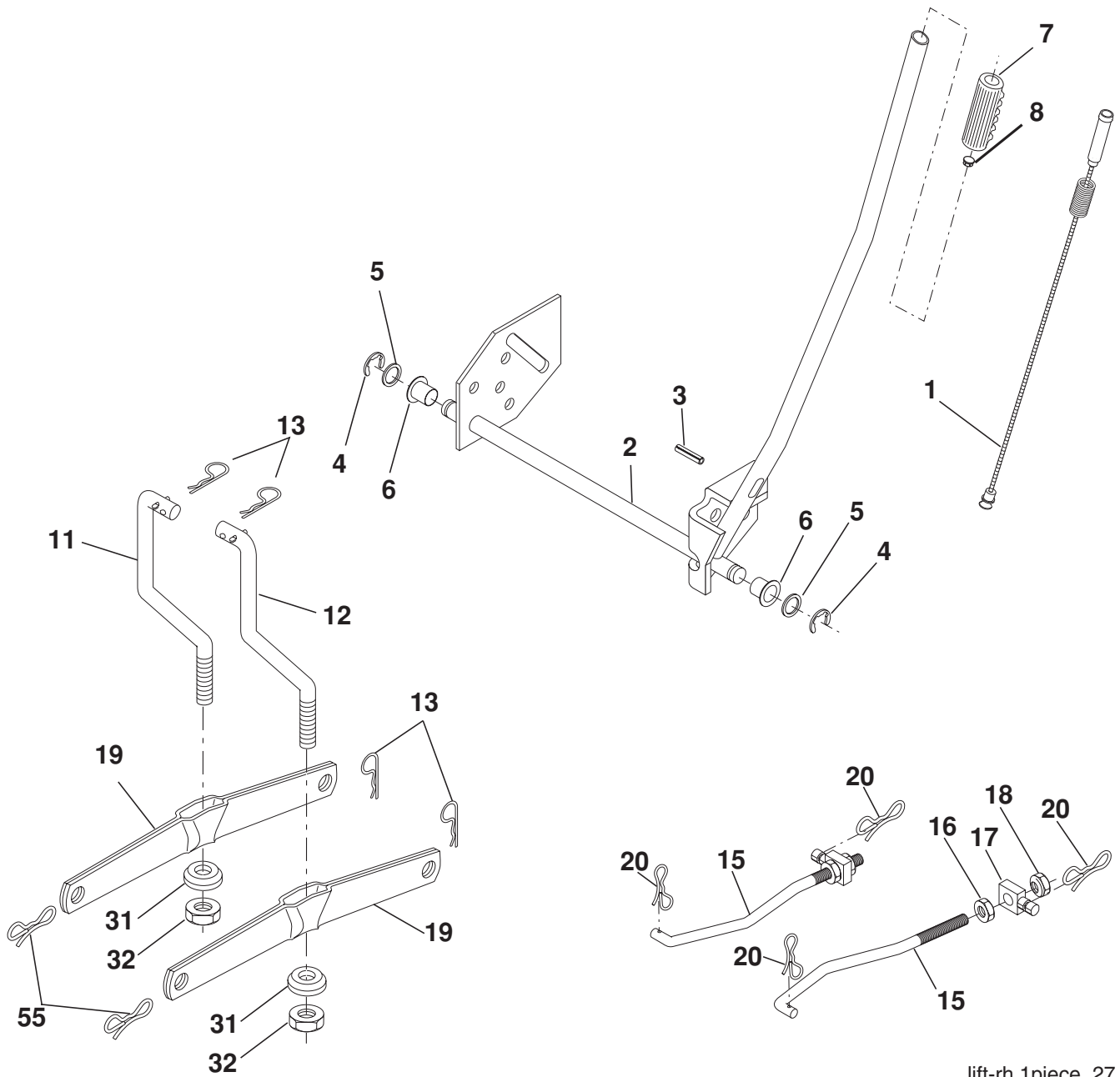

lift-rh.1piece_27

KEY NO.	PART NO.	DESCRIPTION
1	532 15 94-60	Wire Asm Inner W/Plunger
2	532 15 94-71	Shaft Asm Lift
3	532 10 57-67	Pin Groove
4	812 00 00-02	E Ring #5133-62
5	819 21 16-21	Washer PLTD 21/32 x 1 x 21Ga
6	532 12 01-83	Bearing Nylon Blk 629 Id
7	532 10 94-13	Grip Handle Bicycle Matte Blk
8	532 12 45-26	Button Plunger Black
11	532 13 98-65	Link Lift LH
12	532 13 98-66	Link Lift RH

KEY NO.	PART NO.	DESCRIPTION
13	532 12 46-70	Retainer Spring
15	532 17 32-88	Link Front
16	873 35 08-00	Nut Jam Hex 1/2-13 unc
17	532 17 56-89	Trunnion
18	873 80 08-00	Nut Lock W/Wsh 1/2-13 unc
19	532 13 98-68	Arm Suspension Rear
20	532 19 42-09	Pin Cotter 7/16 Bow Tie Lock
31	532 16 98-65	Bearing Pvt Lift
32	873 54 06-00	Nut Crownlock 3/8-24
55	532 19 42-08	Pin Cotter 5/16 Bow Tie Lock

NOTE: All component dimensions given in U.S. inches
1 inch = 25.4 mm