

ILLUSTRATED PARTS BREAKDOWN

PARTNER

12 HP, 42" MOWER DECK

LAWN TRACTOR

MODEL NUMBER P19-117EH (P185H46B)

954 12 00-29

TRACTOR- -MODEL NO. P19-117EH (P185H46B), PRODUCT NO. 954 12 00-29 SCHEMATIC

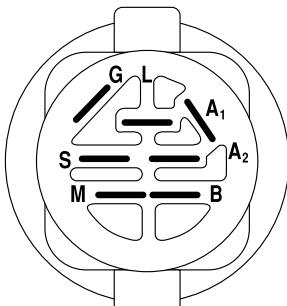
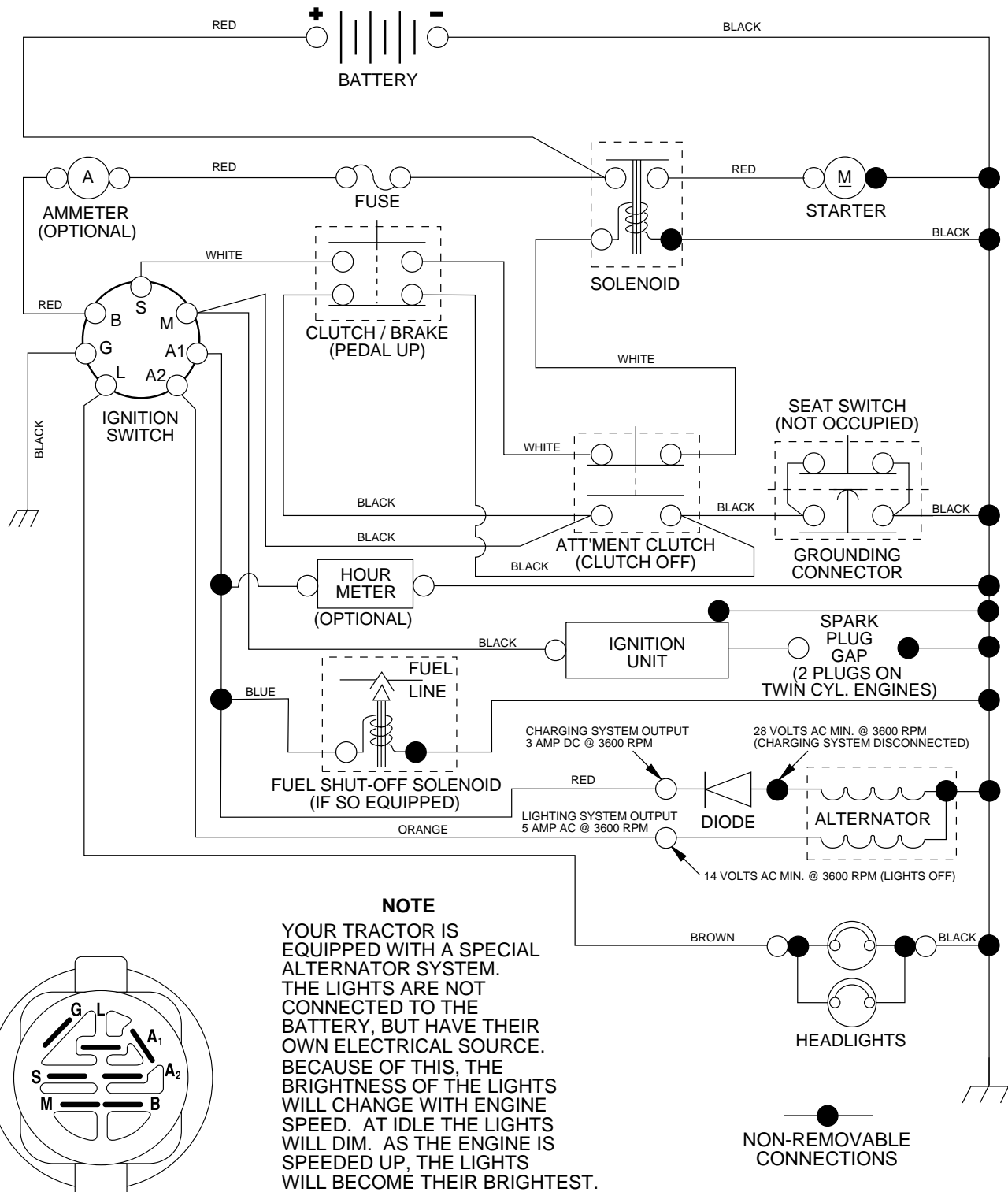

IGNITION SWITCH

POSITION	CIRCUIT	"MAKE"
OFF	M+G+A1	NONE
RUN/LIGHT	B+A1	A2+L
RUN	B+A1	NONE
START	B + S + A1	NONE

NOTE
YOUR TRACTOR IS EQUIPPED WITH A SPECIAL ALTERNATOR SYSTEM. THE LIGHTS ARE NOT CONNECTED TO THE BATTERY, BUT HAVE THEIR OWN ELECTRICAL SOURCE. BECAUSE OF THIS, THE BRIGHTNESS OF THE LIGHTS WILL CHANGE WITH ENGINE SPEED. AT IDLE THE LIGHTS WILL DIM. AS THE ENGINE IS SPEEDED UP, THE LIGHTS WILL BECOME THEIR BRIGHTEST.

WIRING INSULATED CLIPS

NOTE: IF WIRING INSULATED CLIPS WERE REMOVED FOR SERVICING OF UNIT, THEY SHOULD BE REPLACED TO PROPERLY SECURE YOUR WIRING.

NON-REMOVABLE CONNECTIONS

REMOVABLE CONNECTIONS

REPAIR PARTS

TRACTOR- -MODEL NO. P19-117EH (P185H46B), PRODUCT NO. 954 12 00-29
ELECTRICAL

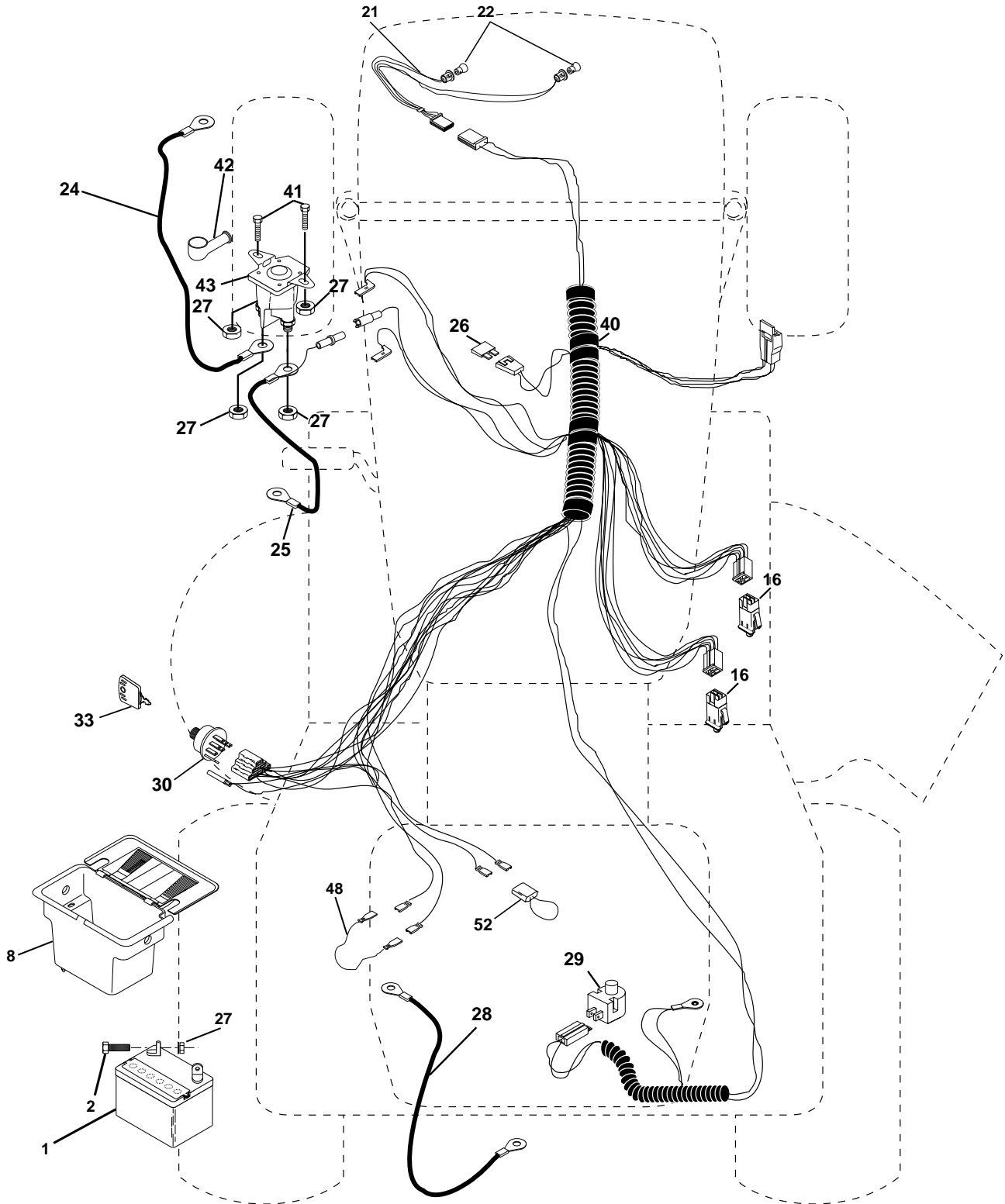

REPAIR PARTS

TRACTOR- -MODEL NO. P19-117EH (P185H46B), PRODUCT NO. 954 12 00-29
ELECTRICAL

KEY NO.	PART NO.	DESCRIPTION
1	532144925	Battery 12 Volt 25 AMP
2	874760412	Bolt Hex Hd 1/4-20unc X 3/4
8	532156417	Case Battery Hng Mech W/lid
16	532153664	Switch Interlock Push-In
21	532166181	Harness Asm Light W/4152j
22	532004152	Bulb Light #1156
24	532124780	Cable Battery 6 Ga 11" Red
25	532146147	Cable Battery 6 Ga Red w/16 wir
26	532166180	Fuse 15 AMP
27	873510400	Nut Keps Hex 1/4-20 Unc
28	532124773	Cable Ground 6 Ga 12" black
29	532121305	Switch Plunger Nc Gray
30	532163968	Switch Ign
33	532140401	Key
40	532170217	Harness Ing Cl Am Hm
41	871110408	Bolt Blk Fin Hex 1/4 - 20 x 1/2
42	532131563	Cover Terminal Red
43	532145673	Solenoid
48	532140844	Adapter Ammeter Rectangular
52	532141940	Protection Wire Loop

NOTE: All component dimensions given in U.S. inches.
1 inch = 25.4 mm.

REPAIR PARTS

TRACTOR- -MODEL NO. P19-117EH (P185H46B), PRODUCT NO. 954 12 00-29
CHASSIS AND ENCLOSURES

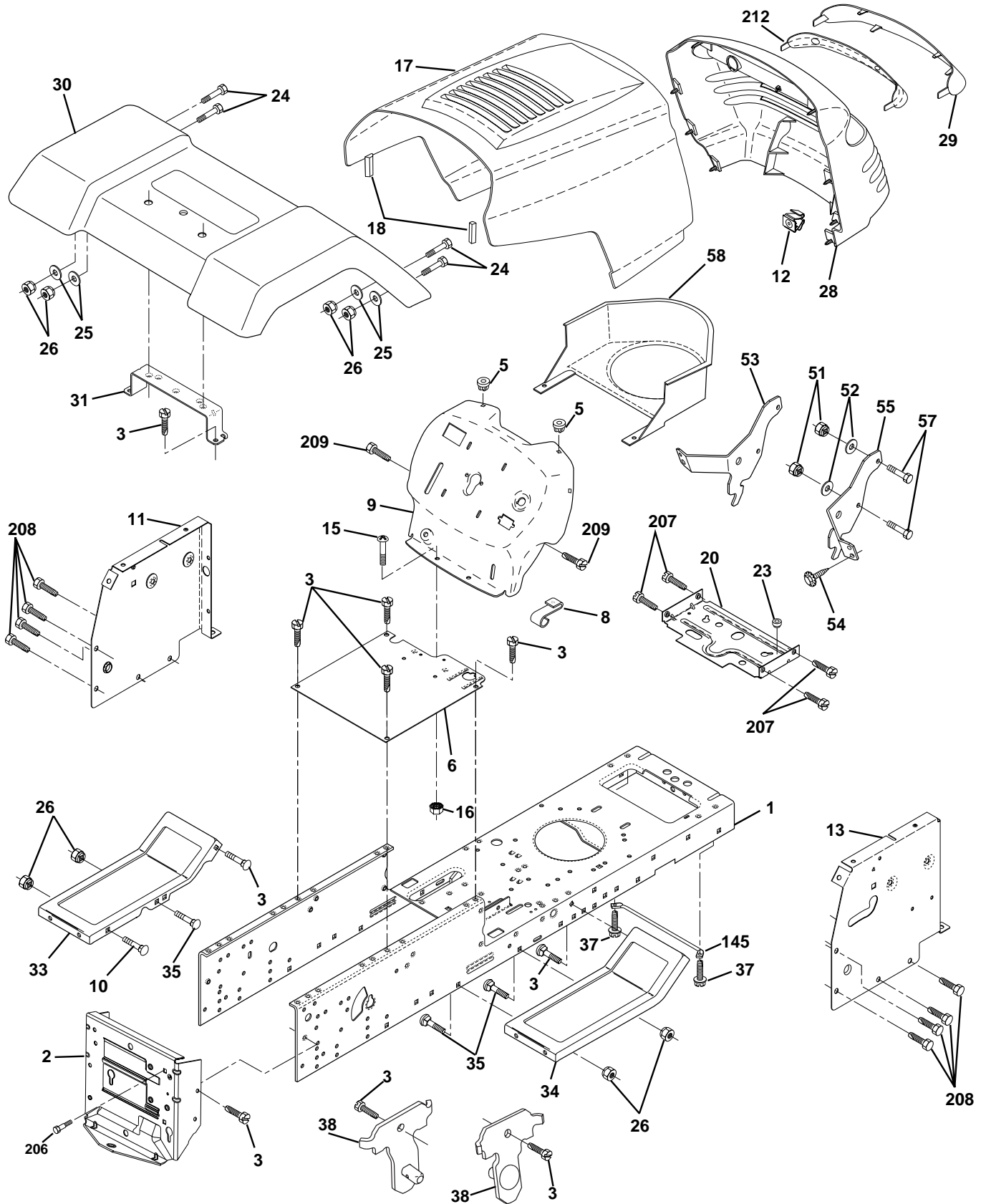

REPAIR PARTS

TRACTOR- -MODEL NO. P19-117EH (P185H46B), PRODUCT NO. 954 12 00-29
CHASSIS AND ENCLOSURES

KEY NO.	PART NO.	DESCRIPTION
1	532169831	Chassis
2	532169061	Drawbar
3	817060612	Screw 3/8-16 x .75
5	532155272	Bumper Hood Dash
6	532155923	Saddle Flat
8	532155138	Clip Retainer Slide-On
9	532172243	Dash
10	872140608	Bolt Rdhd Sqnk 3/8-16unc X 1
11	532155927	Panel Dash LH
12	532145660	Clip Tinnerman Grille P/L
13	532173025	Panel Dash RH
15	874180512	Screw Mach THD 5/16-18 x 3/4
16	873510500	Nut Keps 5/16-18
17	532160382	Hood
18	532126938	Bumper Hood
20	532156437	Plate Mtg Battery/Fuel
23	532134028	Bushing Snap Nyl Blk Fuel Line
24	874780616	Bolt Fin Hex 3/8-16unc X 1 Gr. 5
25	819131312	Washer 13/32 X 13/16 X 12 Ga.
26	873800600	Nut Lock Hex w/Ins 3/8-16 Unc
28	532143499	Grille / Lens
29	532168154	Lens Grille Private Label
30	532173748	Fender
31	532136619	Bracket Fender Repl 109873x
33	532147203	Footrest Pnt LH
34	532147202	Footrest Pnt RH
35	872110606	Bolt Rdhd Sht Sqnk 3/8-16 X3/4
37	817490508	Screw Thdrol 5/16-18 x 1/2 Tyt
38	532169834	Bracket Asm Pivot Mower Rear
51	873800400	Nut Lock w/Insert 1/4-20
52	819091416	Washer 9/32 x 7/8 x 16 Ga.
53	532144697	Bracket Grille LH
54	532161464	Screw Hex Wshd 8-18 x 7/8
55	532144696	Bracket Grille RH
57	874780412	Bolt Hex 1/4-20 x 3/4
58	532140547	Air Duct Private Label
145	532156524	Rod Pivot Chassis/Hood
206	532170165	Bolt Shoulder 5/16-18
207	817670508	Screw Thdrol 5/16-18 x 1/2
208	817670608	Screw Thdrol 3/8-16 x 1/2
209	817000612	Screw Hexwsh Thdr 3/8-16 x 3/4
212	532156229	Insert Lens Reflective
--	532005479	Plug Button Blk 359 Dia Choke

NOTE: All component dimensions given in U.S. inches.
1 inch = 25.4 mm.

REPAIR PARTS

TRACTOR- -MODEL NO. P19-117EH (P185H46B), PRODUCT NO. 954 12 00-29
DRIVE

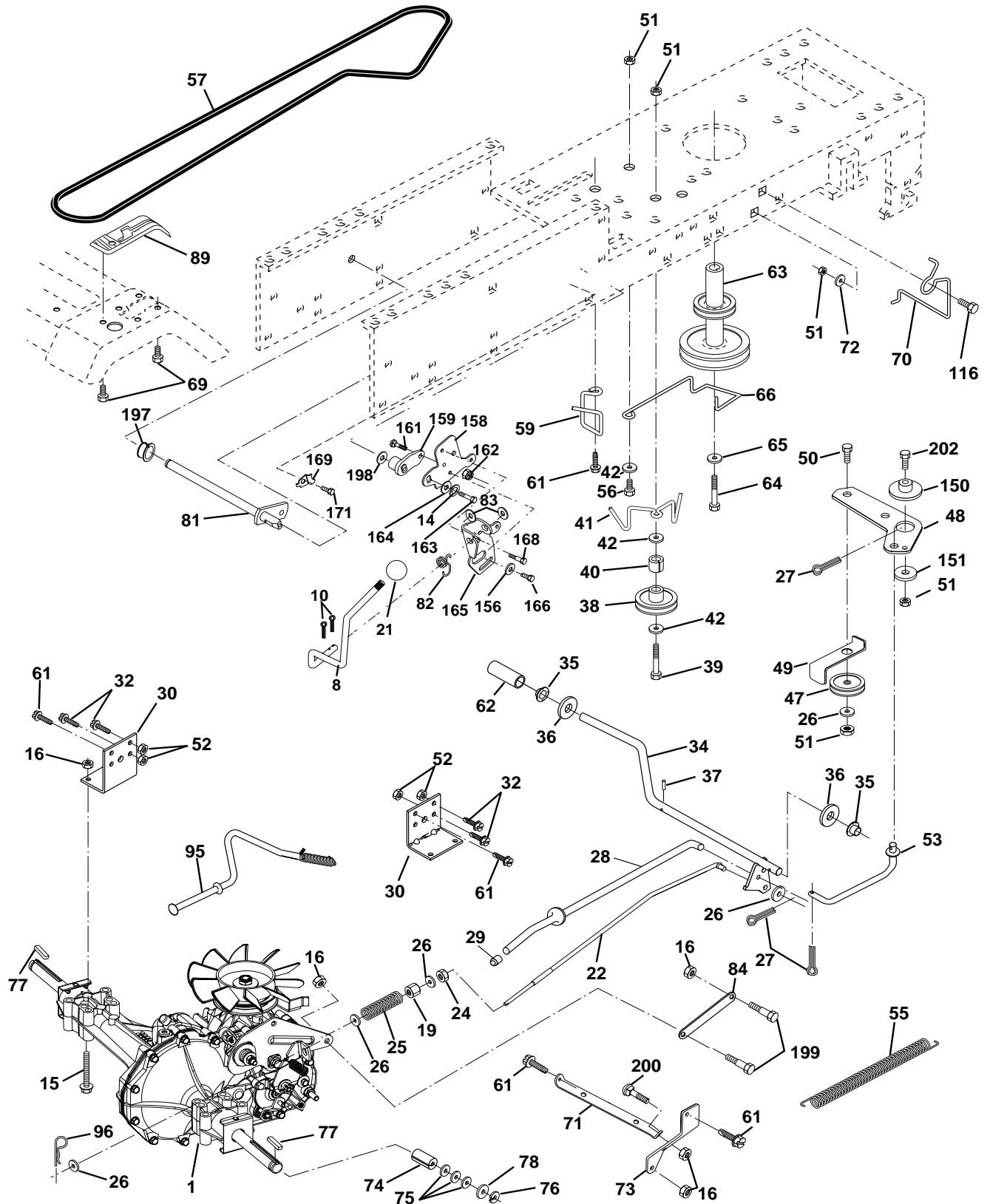

REPAIR PARTS

TRACTOR- -MODEL NO. P19-117EH (P185H46B), PRODUCT NO. 954 12 00-29
DRIVE

KEY NO.	PART NO.	DESCRIPTION	KEY NO.	PART NO.	DESCRIPTION
1	-----	Transaxle Hydro Gr 314-0510	65	810040700	Washer
8	532165619	Rod Shift Fender Adjust	66	532154778	Keeper Belt Engine Hydro
10	876020416	Pin Cotter 1/8 x 1 CAD	69	532142432	Screw Hex Wsh Hi-Lo 1/4-1/2 Unc
14	810040400	Washer Lock Hvy Helical	70	532162848	Keeper Belt Engine
15	874490544	Bolt Hex FLGHD 5/16-18 x Gr 5	71	532169183	Strap Torque Lh Hydro
16	873800500	Nut Lock Hex W/Ins. 5/16-18 Unc	72	819132012	Washer 13/32 x 1-1/4 x 12 auge
19	873800600	Nut Lock Hex W/Wsh 3/8-16 Unc	73	532169182	Strap Torque Rh Hydro
21	532140845	Knob, Deluxe 1/2-13	74	532169496	Spacer, Split
22	532169498	Rod, Brake Hydro	75	532121749	Washer 25/32 x 1-1/4 x 16 Gauge
24	873350600	Nut, Hex Jam 3/8-16 Unc	76	812000001	E-Ring
25	532106888	Spring, Brake Rod	77	532123583	Key, Square
26	819131316	Washer	78	532121748	Washer 25/32 x 1-5/8 x 16 Gauge
27	876020412	Pin Cotter 1/8 x 3/4 CAD.	81	532165596	Shaft Asm Cross Tapered
28	532145204	Rod, Parking Brake	82	532123782	Spring Torsion
29	532071673	Cap, Parking Brake	83	819171216	Washer 17/32 x 3/4 x 16 Ga.
30	532169592	Bracket, Transaxle	84	532169594	Link Transaxle
32	874760512	Bolt Hex Hd 5/16-18 Unc x 3/4	89	532173029	Console, Shift
34	532155071	Shaft, Foot Pedal	95	532170201	Control Bypass Hydro 20" Tires
35	532120183	Bearing, Nylon	96	532124788	Retainer Spring 1" Zinc/Cad
36	819211616	Washer	116	872110610	Bolt Rdhd Sqneck 3/8-16 x 1.25
37	532124963	Pin, Roll	150	532165850	Bushing Bellcrank Grd Drive
38	532131494	Pulley, Idler, Flat	151	819133210	Washer 13/32 x 2 x 10 Ga.
39	874760644	Bolt	156	532166002	Washer Srrted 5/16ID x 1.125
40	532124965	Spacer, Split	158	532165589	Bracket Shift Mount
41	532165838	Keeper, Belt Idler	159	532165494	Hub Tapered Flange Shift Lt
42	819131312	Washer 13/32 x 13/16 x 12 Gauge	161	872140406	Bolt Rdhd Sqnk 1/4-20 x 3/4 Gr 5
47	532127783	Pulley, Idler, V-Groove	162	873680400	Nut Crownlock 1/4-20 Unc
48	532154407	Bellcrank, Clutch	163	874780416	Bolt Hex Fin 1/4-20 Unc x 1 Gr 5
49	532123205	Retainer, Belt	164	819091010	Washer 5/8 x .281 x 10 Ga
50	874760624	Bolt	165	532165623	Bracket Pivot Lever
51	873680600	Nut Crownlock 3/8-16 UNC	166	532166880	Screw 5/16-18 x 5/8
52	873680500	Nut, Crownlock 5/16-18 Unc	168	532165492	Bolt Shoulder 5/16-18 x .561
53	532105710	Link, Clutch	169	532165581	Plate Fastening
55	532105709	Spring, Return, Clutch	171	817490608	Screw Thdrol 3/8-16 x 1/2 TY-TT
56	874760620	Bolt Hex 3/8-16 x 1-1/4	197	532169613	Nyliner Snap-In 5/8"ID
57	532140294	V-Belt	198	532169593	Washer Nyl 7/8 ID x .105" Hyd
59	532169691	Keeper, Center Span	199	532169612	Bolt Shoulder 5/16-18UNC
61	817060612	Screw . 3/8-16 x 3/4	200	872140508	Bolt Rdhd Sgnk 5/16-18UNC x 1
62	532124872	Cover, Pedal	202	872110612	Bolt Carr Sh 3/8-16 x 1-1/2 Gr.5
63	532140186	Pulley, Engine			
64	871170764	Bolt Hex 7/16-20 x 4 Gr. 5			

NOTE: All component dimensions given in U.S. inches
1 inch = 25.4 mm

REPAIR PARTS

TRACTOR- -MODEL NO. P19-117EH (P185H46B), PRODUCT NO. 954 12 00-29
STEERING ASSEMBLY

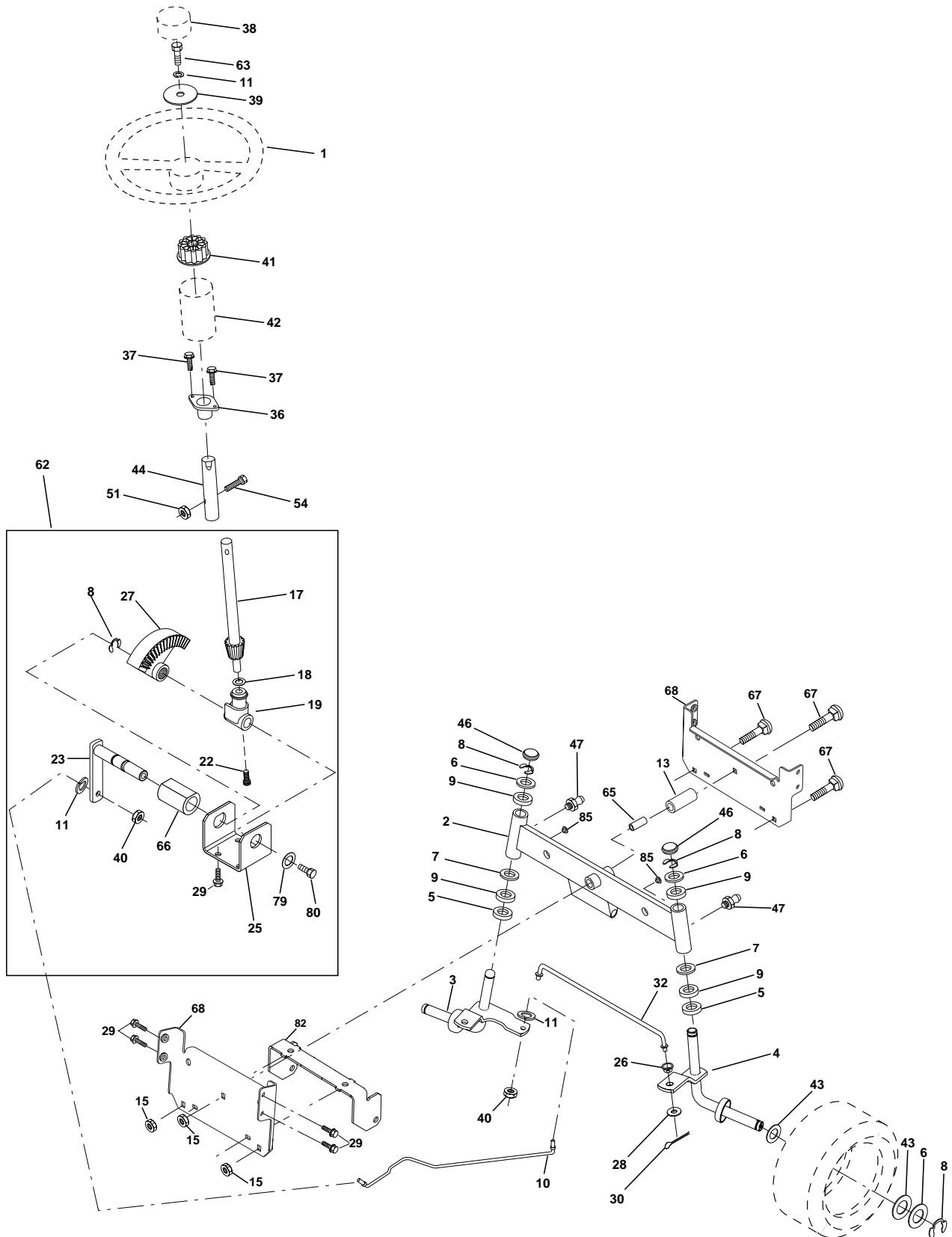

REPAIR PARTS

TRACTOR- -MODEL NO. P19-117EH (P185H46B), PRODUCT NO. 954 12 00-29
STEERING ASSEMBLY

KEY NO.	PART NO.	DESCRIPTION
1	532139768	Wheel Steering Opp. Sears Blk
2	532154427	Axle Asm Fr
3	532169840	Spindle Asm LH
4	532169839	Spindle Asm RH
5	532124931	Bearing Race Thrust Harden
6	532121748	Washer 25/32 x 1-5/8 x 16 Ga
7	819272016	Washer 27/32 x 1-1/4 x 16 Ga
8	812000029	Ring Klip #t5304-75
9	532124937	Bearing Col Strg Blk
10	532169832	Link Drag
11	810040600	Washer Lock Hvy Hlcl Spr 3/8
13	532136518	Spacer Brace Axle
15	532145212	Nut Hexflange Lock
17	532156546	Shaft Asm Strg
18	532057079	Washer Thrust 515 x 750 x 033
19	532160395	Support Shaft
22	532165857	Screw Hex Wshhd Torx
23	532165851	Shaft Asm Pittman
25	532154406	Bracket Steering
26	532126847	Bushing Link Drag Blk LR
27	532136874	Gear Sector
28	819131416	Washer 13/32 x 7/8 x 16 Ga
29	817060612	Screw 3/8-16 x .75
30	876020412	Pin Cotter 1/8 x 3/4 Cad
32	532130465	Rod Tie Wire Form 19 75 Mech
36	532155099	Bushing Strg Nat .623/.618ld
37	532152927	Screw TT #10-32 x 5 x 3/8 Flange
38	532140175	Cap Wheel Steer P/L
39	819133812	Washer 13/32 x 2-3/8 x 12 Ga
40	532124701	Nut Lock Center 3/8-24unf
41	532100711	Adaptor Wheel Strg
42	532169633	Boot Shaft Steering
43	532121749	Washer 25/32 X 1 1/4 X 16 Ga
44	532153720	Extension Steering
46	532121232	Cap Spindle Fr Top Blk
47	532124836	Fitting Grease
51	873800500	Nut Lock Hx w/Ins 5/16-18 Unc
54	874780520	Bolt Fin Hex 5/16-18 Unc x 1-1/4
62	532167902	Kit Steering Assembly Serv
63	874780616	Bolt Fin Hex 3/8-16 UNC Gr. 5
65	532160367	Spacer Brace Axle
66	532154404	Bearing Arm Pittman
67	872140618	Bolt RDHD SQ 3/8-16 UNC x 2-1/4
68	532169827	Brace Axle
79	819132012	Washer 13/32 x 1-1/4 x 12 Ga.
80	874950612	Bolt Hex Nylon 3/8-16 x 3/4
82	532169835	Bracket Susp. Chassis Front
85	532133835	Fastener Christmas Tree

NOTE: All component dimensions given in U.S. inches.
1 inch = 25.4 mm.

REPAIR PARTS

TRACTOR- -MODEL NO. P19-117EH (P185H46B), PRODUCT NO. 954 12 00-29 SEAT ASSEMBLY

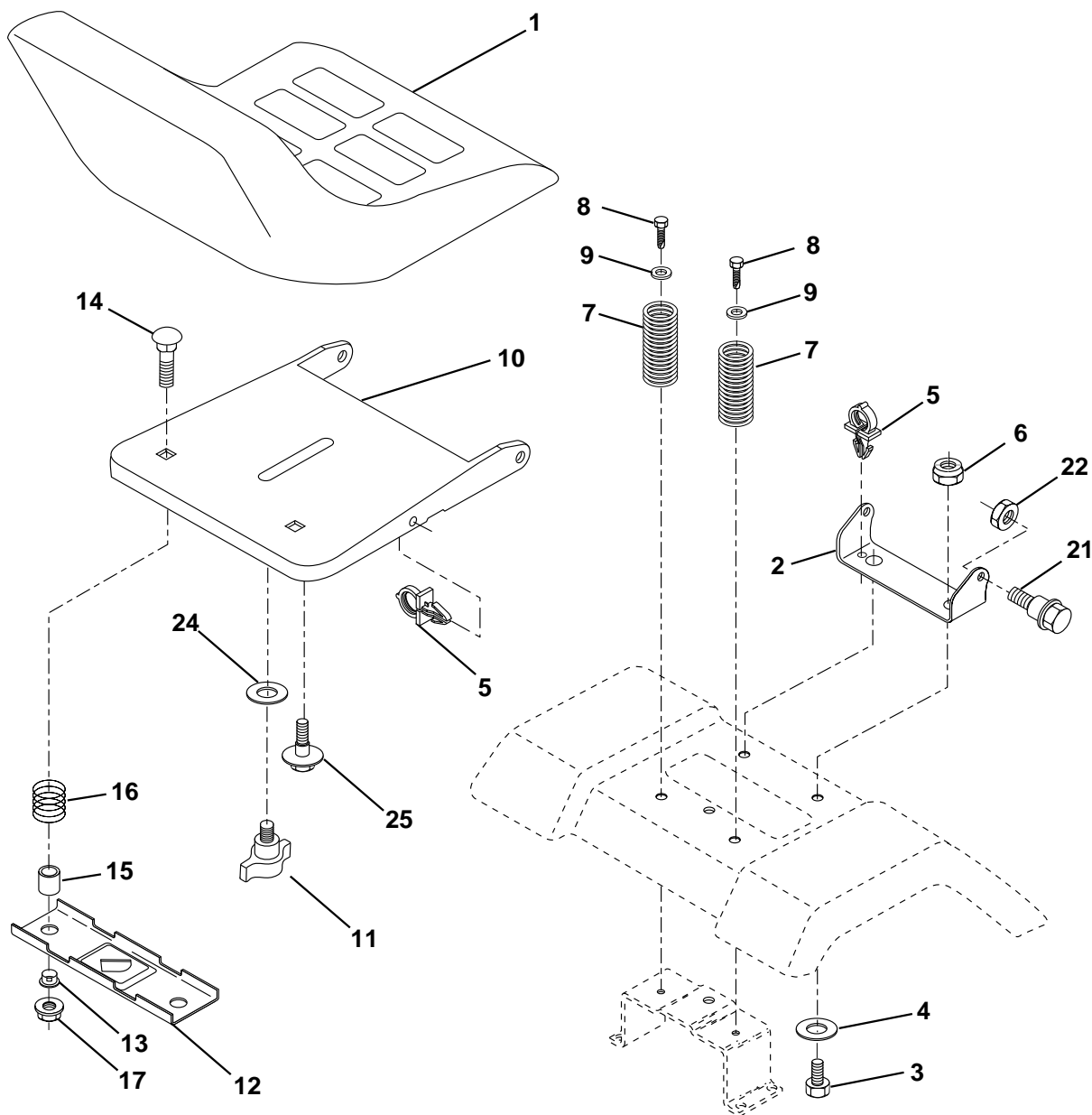

KEY NO.	PART NO.	DESCRIPTION
1	532140118	Seat
2	532140551	Bracket Pivot Seat 8 720
3	871110616	Bolt Fin Hex 3/8-16unc X 1
4	819131610	Washer 13/32 X 1 X 10 Ga
5	532145006	Clip Push-In
6	873800600	Nut Lock Hex w/Wsh 3/8-16 Unc
7	532124181	Spring Seat Cprsn 2 250 Blk Zi
8	817000616	Screw 3/8-16 X 1.5
9	819131614	Washer 13/32 X 1 X 14 Ga.
10	532155925	Pan Seat
11	532166369	Knob
12	532121246	Bracket Mounting Switch

KEY NO.	PART NO.	DESCRIPTION
13	532121248	Bushing Snap Blk Nyl 50 Id
14	872050412	Bolt Rdhd Sht Nk 1/4-20x1-1/2
15	532121249	Spacer Split 28x 88 Yel Zinc
16	532123740	Spring Cprsn
17	532123976	Nut Lock 1/4 Lge Flg Gr 5 Zinc
21	532171852	Bolt Shoulder 5/16-18 Unc -2A
22	873800500	Nut Lock Hex W/Insert 5/16-18 UNC
24	819171912	Washer 17/32 X 1-3/16 X 12 Ga.
25	532127018	Bolt Shoulder 5/16-18 X 62

NOTE: All component dimensions given in U.S. inches.
1 inch = 25.4 mm

REPAIR PARTS

TRACTOR- -MODEL NO. P19-117EH (P185H46B), PRODUCT NO. 954 12 00-29
DECALS

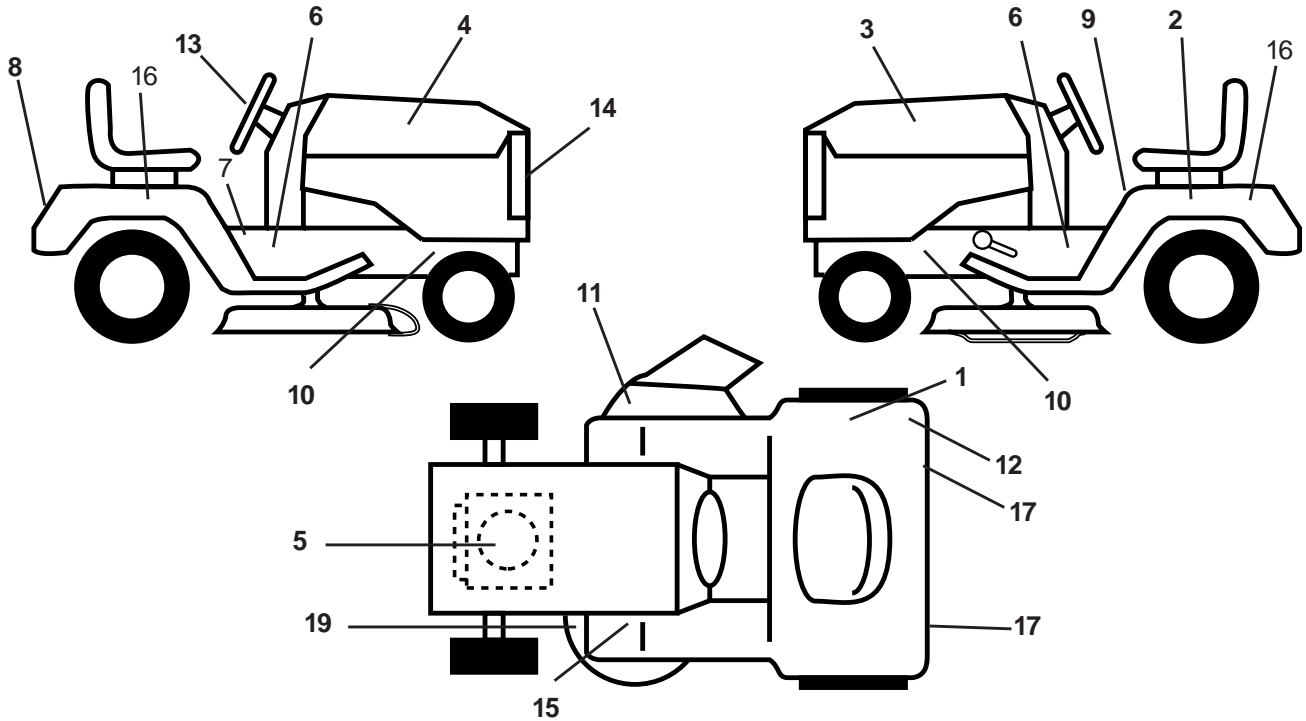

KEY NO.	PART NO.	DESCRIPTION
1	532145437	Decal Europe Stand CE
2	532145005	Decal Bat Dan/Poi P/L Symbols
3	532166754	Decal Hood LH
4	532166753	Decal Hood RH
5	532170849	Decal Engine
6	532137588	Decal Chas. Turbo Collection
7	532140837	Decal Saddle Brake Parking
8	532140987	Decal Fender Bernard
9	532145498	Decal Read Owners Manual Syms
10	532159736	Decal Chassis Hot Muffler
11	532145494	Decal Mower Cut finger Symbol
12	532126187	Decal 100 DbA
13	532146998	Decal Strg Wheel Cap

KEY NO.	PART NO.	DESCRIPTION
14	532140986	Decal Logo Grille
15	532159737	Decal Brake/Clutch
16	532171313	Decal Fend Auto Radius
17	532106202	Reflector Tail Light
19	532139346	Decal V-Belt Sch
--	532171237	Pad Footrest
--	532169210	Decal Bypass Lt Hydro
--	532162598	Decal Drawbar Load Limit
--	532138311	Decal Lift Handle (Lift Handle)
--	532172491	Manual Operator's Euro
--	532172492	Manual Operator's Scan

WHEELS & TIRES

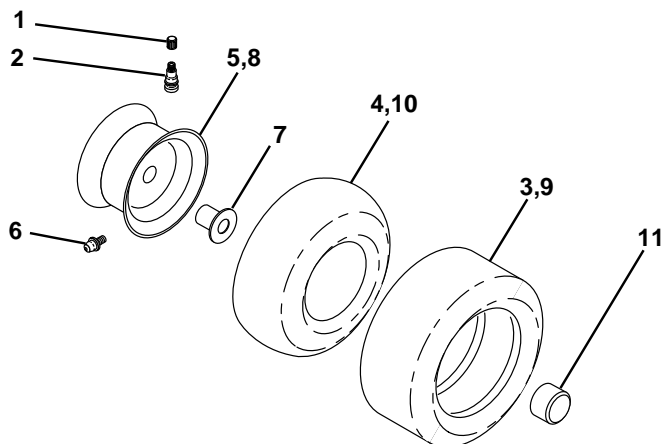

KEY NO.	PART NO.	DESCRIPTION
1	532059192	Cap Valve Tire
2	532065139	Stem Valve
3	532106222	Tire F Ts 15 X 6 0 - 6 Service
4	532059904	Tube Front (Service Item Only)
5	532125121	Rim Asm 6" front Yellow Service
6	532124957	Fitting Grease (Front Wheel Only)
7	532124959	Bearing Flange (Front Wheel Only)
8	532125122	Rim Asm 8" rear Yellow Service
9	532122082	Tire R Ts 20 X10-8 C. Service
10	532124926	Tube Rear (Service Item Only)
11	532104757	Cap Axle Blk 1 50 X 1 00

NOTE: All component dimensions given in U.S. inches
1 inch = 25.4 mm

REPAIR PARTS

TRACTOR- -MODEL NO. P19-117EH (P185H46B), PRODUCT NO. 954 12 00-29
ENGINE

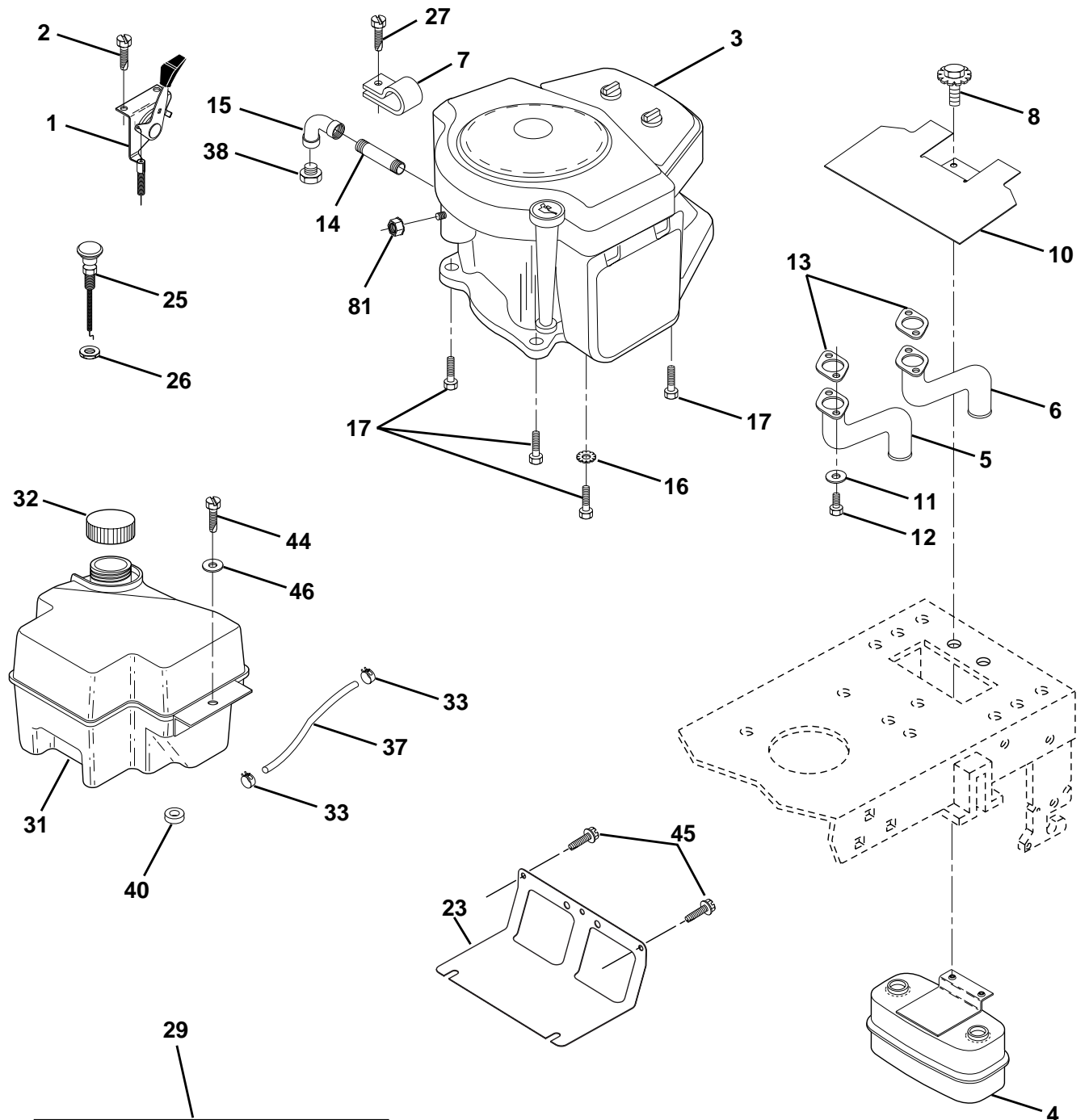

OPTIONAL EQUIPMENT
Spark Arrester

REPAIR PARTS

TRACTOR- -MODEL NO. P19-117EH (P185H46B), PRODUCT NO. 954 12 00-29
ENGINE

KEY NO.	PART NO.	DESCRIPTION
1	532141295	Control Throt 35.5 Lh Flag
2	817720410	Screw Hex Thd Cut 1/4-20x5/8 T
3	-----	Engine B&S Model 42A777 (Order From Engine Manufacturer)
4	532149723	Muffler Exhaust
5	532144069	Exhaust Asm. Left
6	532144068	Exhaust Asm. Right
7	532138129	Clamp Tube Double Engine
8	532150176	Bolt 5/16-18unc x 3/4 w/sems
10	532145552	Shield Heat
11	810040400	Washer Lock Hvy Helical 1/4
12	874780412	Bolt Fin Hex 1/4-20 Unc x 3/4
13	532165287	Gasket Muffler
14	813280336	Nipple Pipe 4-1/2"
15	813200300	Elbow Std 90 Degree 3/8-18 Npt
16	811050600	Washer Lock Ext Tooth 3/8
17	817490624	Screw Thdrol 3/8-16x1-1/2 Tytt
23	532169837	Sheild Browning
25	532145996	Control Choke
26	873920600	Nut Keps 3/8-24 UNF
27	532152927	Screw TT #10-32.5.3/8. Flange
29	532137180	Arrestor Spark
31	532161911	Tank Fuel Front 2.00
32	532140527	Cap Fuel
33	532123487	Clamp Hose Blk
37	532137040	Line Fuel
38	-----	Plug Oil Drain (Order From Engine Manufacturer)
40	532124028	Bushing
44	817670412	Screw Hex wsh Thdrol 1/4-20 x 3/4
45	817000612	Screw Hex Wsh Thdr 3/8-16 x 3/4 BL
46	819091416	Washer 9/32 x 7/8 x 16 Ga.
81	873510400	Nut Keps Hex 1/4-20

NOTE: All component dimensions given in U.S. inches
1 inch = 25.4 mm

REPAIR PARTS

TRACTOR- -MODEL NO. P19-117EH (P185H46B), PRODUCT NO. 954 12 00-29
MOWER LIFT

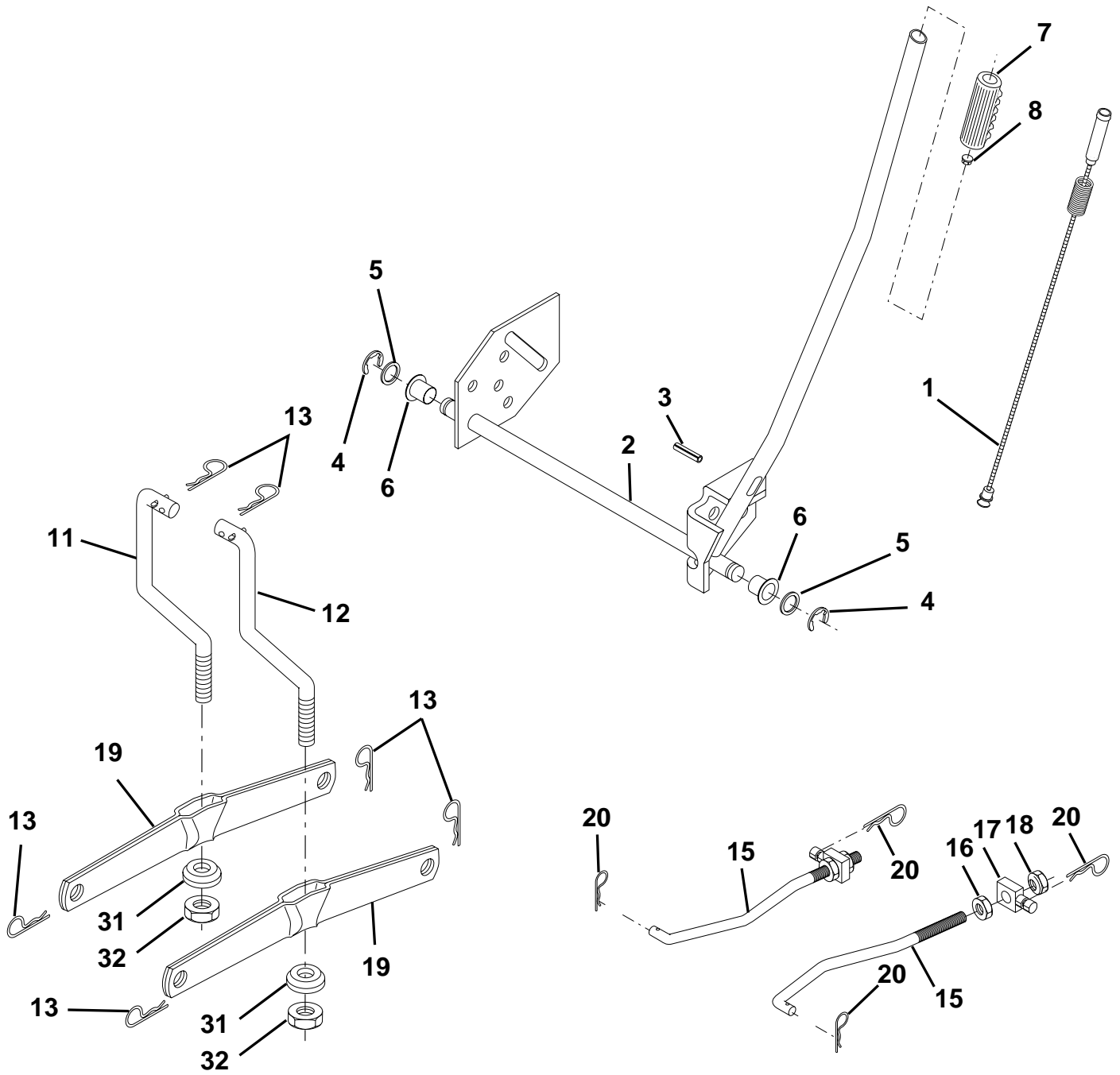

REPAIR PARTS

TRACTOR- -MODEL NO. P19-117EH (P185H46B), PRODUCT NO. 954 12 00-29
MOWER LIFT

KEY NO.	PART NO.	DESCRIPTION
1	532159460	Wire Asm Inner W/Plunger
2	532159471	Shaft Asm Lift
3	532105767	Pin Groove
4	812000002	E Ring #5133-62
5	819211621	Washer PLTD 21/32 X 1 X 21ga
6	532120183	Bearing Nylon Blk 629 Id
7	532109413	Grip Handle Bicycle Matte Blk
8	532124526	Button Plunger Black
11	532139865	Link Lift LH
12	532139866	Link Lift RH
13	532124670	Retainer Spring
15	532173288	Link Front
16	873350800	Nut Jam Hex 1/2-13 Unc
17	532130171	Trunnion Blk Zinc
18	873800800	Nut Lock W/wsh 1/2-13 Unc
19	532139868	Arm Suspension Rear
20	532163552	Retainer Spring
31	532140302	Bearing Pvt Lift Spherical
32	873540600	Nut Crownlock 3/8-24

NOTE: All component dimensions given in U.S. inches
1 inch = 25.4 mm

REPAIR PARTS

TRACTOR- -MODEL NO. P19-117EH (P185H46B), PRODUCT NO. 954 12 00-29
MOWER

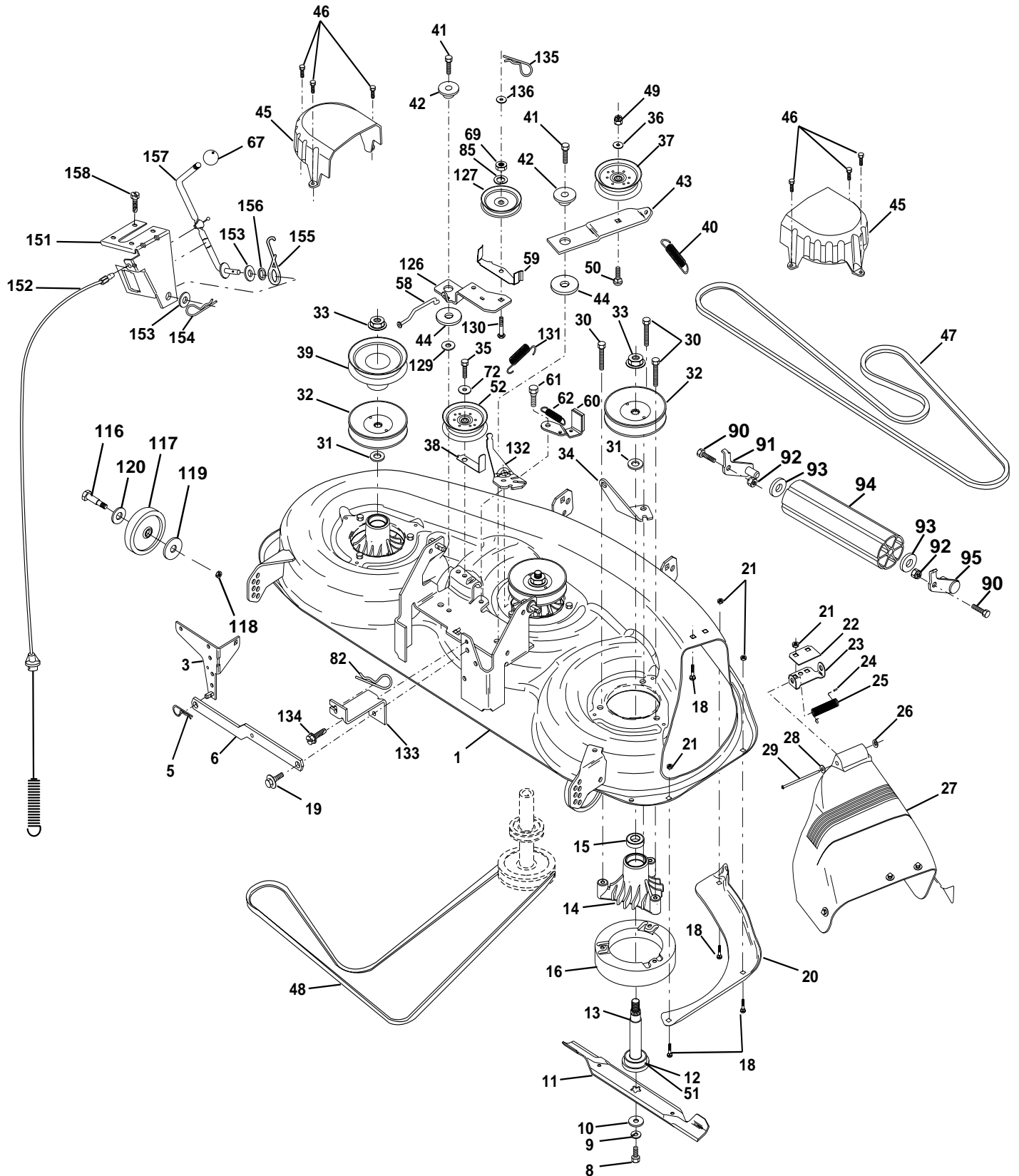

REPAIR PARTS

**TRACTOR- -MODEL NO. P19-117EH (P185H46B), PRODUCT NO. 954 12 00-29
MOWER**

KEY NO.	PART NO.	DESCRIPTION	KEY NO.	PART NO.	DESCRIPTION
1	532164210	Deck Asm., Mower 46"	51	532153390	Washer Felt
3	532138457	Bracket Asm., Sway Bar	52	532165888	Pulley Idler
5	532124670	Retainer Spring	58	532165906	Rod Brake 46"
6	532130832	Arm, Suspension, Rear (Sway Bar)	59	532157034	Guide Belt 46"
8	532850857	Bolt, Patched 3/8-24 x 1-1/4 Gr. 8	60	532156722	Arm Asm Brake
9	810030600	Washer, Lock Hvy., Unplated 3/8	61	532161315	Bolt Shld 5/16-18 Ty TT
10	532140296	Washer, Hard Blade, Mower Vented	62	532131870	Spring Return
11	532170698	Blade, 46" Hi Perf	67	532106932	Knob Rd 3/8-16 Plstc Thds
12	532129895	Bearing, Ball, Mandrel #6204	69	873350600	Nut Hex Jam 3/8-16 UNC
13	532137553	Shaft Asm. w/Lower Bearing (Includes Key No. 12)	72	819131316	Washer 13/32 x 13/16 x 16 Ga.
14	532137152	Housing, Mandrel	82	532124788	Retainer Spring 1"
15	532110485	Bearing, Ball, Mandrel	85	810040600	Washer Lock Hvy Hlcl Spr. 3/8
16	532140329	Stripper, Mower Round	90	874760616	Bolt Fin Hex 3/8-16 x 1
18	872140505	Bolt, Carriage 5/16-18 x 5/8	91	532132274	Bracket Asm Noseroller Lh
19	532132827	Bolt, Hex Head, Shoulder 5/16-18	92	873800600	Nut Lock Hex w/ Ins 3/8-16 UNC
20	532145055	Baffle, Vortex Mower 46"	93	819171416	Washer 17/32 x 7/8 x 16 Ga.
21	873680500	Nut, Crownlock 5/16-18 UNC	94	532132264	Roller Nose 38/42
22	532134753	Stiffener, Bracket	95	532132273	Bracket Asm Noseroller Rh
23	532131267	Bracket, Deflector	116	532124842	Bolt, Shoulder
24	532105304	Cap, Sleeve	117	532105455	Gauge Wheel, Narrow
25	532149287	Spring, Torsion, Deflector	118	873930600	Nut, Centerlock 3/8-16 UNC
26	532110452	Nut, Push	119	819121414	Washer 3/8 x 7/8 x 14 Ga.
27	532166883	Deflector Clipping 46	120	819171512	Washer 17/32 x 15/16 x 12 Ga.
28	819111016	Washer 11/32 x 5/8 x 16 Ga.	126	532156472	Arm, Idler, Primary Deck 46"
29	532131491	Rod, Hinge	127	532146763	Pulley, Idler, V-Groove Dim. 4.25
30	532157722	Screw Thd Rolling Washer Head	129	819133808	Washer 13.32 x 2-3/8 x 8 Ga.
31	532129963	Washer, Spacer Mower Vented	130	532165891	Bolt Carriage Idler
32	532153531	Pulley, Mandrel	131	532169022	Spring Return Idler
33	532137266	Nut, Flg. Top Lock Cntr. 9/16	132	532165890	Arm Spring Brake Mower
34	532144945	Anchor, Spring Deck 46"	133	532165904	Bracket Anchor Cable 46"
35	817490628	Screw, Thdroll 3/8-16 x 1-3/4 Tytt	134	817490512	Screw Thdrol 5/16-18 x 3/4
36	819131316	Washer 13/32 x 13/16 x 16 Ga.	135	532165898	Retainer Spring Yellow
37	532131494	Pulley, Idler, Flat	136	819091216	Washer Flat 3/8" Type B
38	532156086	Keeper, Belt, Idler	151	532169670	Bracket Clutch Cable
39	532144917	Pulley, Idler, Driven	152	532170328	Clutch Cable 38"/46"
40	532137273	Spring, Secondary 44/46/50 Vent	153	532169674	Washer Flate 3/8" Type B
41	817060620	Screw 3/8-16 x 1-1/4 SMGML.TAP	154	532169675	Spring Retainer
42	532165723	Spacer, Retainer	155	532169671	Spring Retention
43	532144949	Arm, Idler Secondary	156	532169672	Spacer Clutch Cable
44	532133943	Washer, Hardened	157	532169669	Rod Clutch Cable 38"
45	532145059	Cover, Mandrel Deck	158	817720410	Screw Hex Thd Cut 1/4-20 x 5/8
46	532137729	Screw, Thdroll. 1/4-20 x 5/8	--	532172497	Deck Complete (Std. Deck-Order separately gauge wheel components Key Nos. 116-118)
47	532144959	V-Belt, Mower, Secondary	--	532143651	Mandrel Asm Service
48	532139573	V-Belt, Mower, Primary			
49	873680600	Nut, Crownlock 3/8-16 UNC			
50	872110612	Bolt, Carriage 3/8-16 x 1-1/2 Gr. 5			

NOTE: All component dimensions given in U.S. inches
1 inch = 25.4 mm