

ILLUSTRATED PARTS LIST

MODEL NO. 96011021600

CUSTOMER CATALOG NO. PP18542

PRODUCT NO. 960 11 02-16

REPAIR PARTS

TRACTOR - - MODEL NO. PP18542 (96011021600), PRODUCT NO. 960 11 02-16 SCHEMATIC

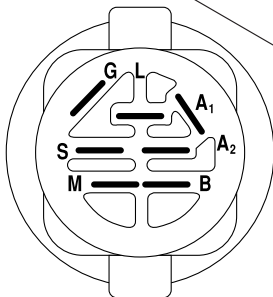
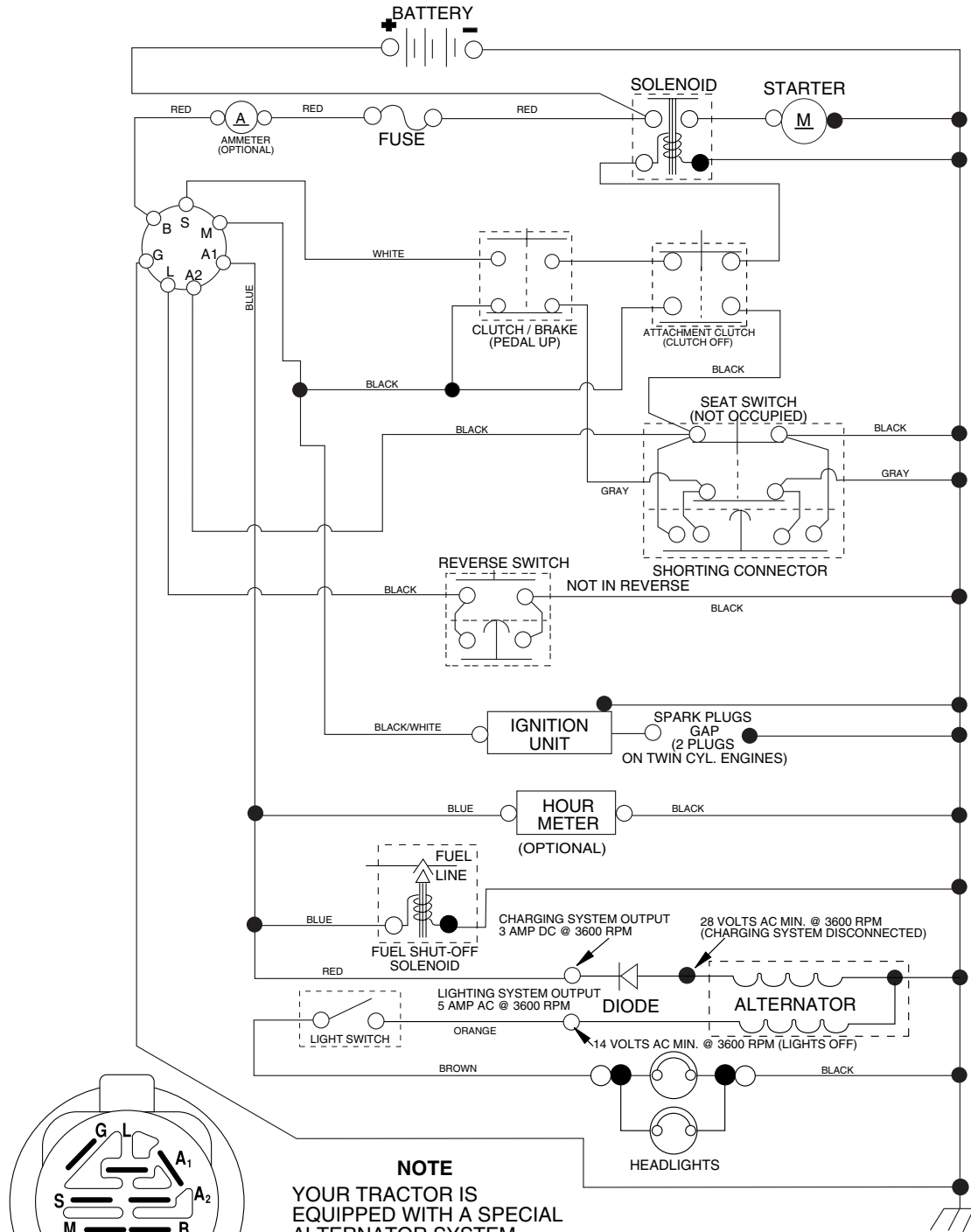

IGNITION SWITCH

POSITION	CIRCUIT "MAKE"
OFF	M+G+A1
RUN/OVERRIDE	B+A1
RUN	B+A1 L+A2
START	B + S + A1

02836

NOTE

YOUR TRACTOR IS EQUIPPED WITH A SPECIAL ALTERNATOR SYSTEM. THE LIGHTS ARE NOT CONNECTED TO THE BATTERY, BUT HAVE THEIR OWN ELECTRICAL SOURCE. BECAUSE OF THIS, THE BRIGHTNESS OF THE LIGHTS WILL CHANGE WITH ENGINE SPEED. AT IDLE THE LIGHTS WILL DIM. AS THE ENGINE IS SPEEDED UP, THE LIGHTS WILL BECOME THEIR BRIGHTEST.

●
NON-REMOVABLE CONNECTIONS

○
REMOVABLE CONNECTIONS

WIRING INSULATED CLIPS

NOTE: IF WIRING INSULATED CLIPS WERE REMOVED FOR SERVICING OF UNIT, THEY SHOULD BE REPLACED TO PROPERLY SECURE YOUR WIRING.

REPAIR PARTS

TRACTOR -- MODEL NO. PP18542 (96011021600), PRODUCT NO. 960 11 02-16
DECALS

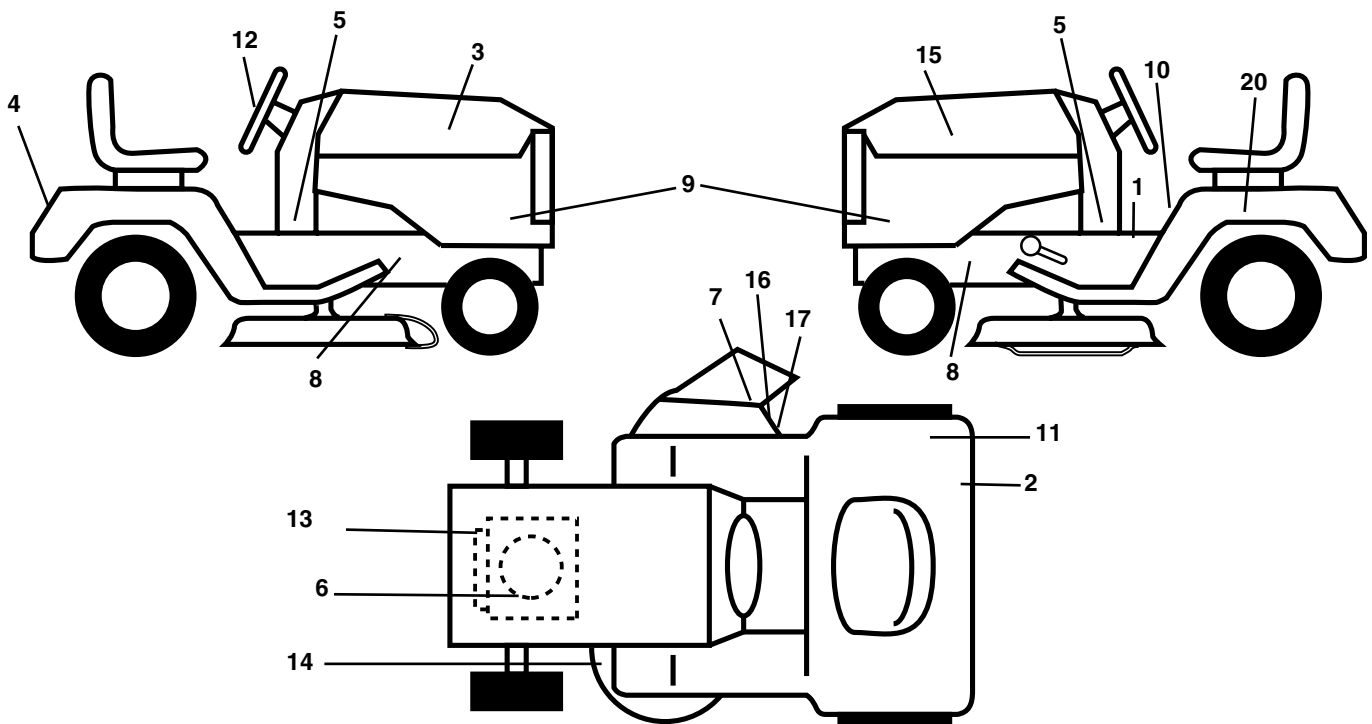

KEY NO.	PART NO.	DESCRIPTION
1	532 15 97-37	Decal Brake Clutch
2	532 14 08-37	Decal Parking Brake
3	532 18 61-63	Decal Hood RH
4	532 17 27-40	Decal Fender
5	532 40 24-36	Decal Dash
6	532 18 92-88	Decal Engine
7	532 17 91-28	Decal Deck B 42
8	532 15 97-36	Decal Chassis Hot Muffler
9	532 18 92-90	Decal Hood Side Panel
10	532 40 03-89	Decal Warning Symbols CE
11	532 16 88-69	Decal Tick Mark
12	532 17 27-43	Decal Steering Wheel
13	532 19 68-41	Decal Warning Eng. Syms.

KEY NO.	PART NO.	DESCRIPTION
14	532 16 03-96	Decal V-Belt Schematic
15	532 18 61-64	Decal Hood LH
16	532 18 2166	Decal Cutfinger CE
17	532 19 63-57	Decal Deflect. Warning Cutfinger Sym.
20	532 14 50-05	Decal Bat Dan/Psn
--	532 16 25-98	Decal Drawbar Load
--	532 13 83-11	Decal Handle Lft Height Adjust
--	532 18 82-52	Pad Footrest RH
--	532 18 82-53	Pad Footrest LH
--	532 40 36-42	Manual Operator's (English)
--	532 40 36-43	Manual Parts

WHEELS & TIRES

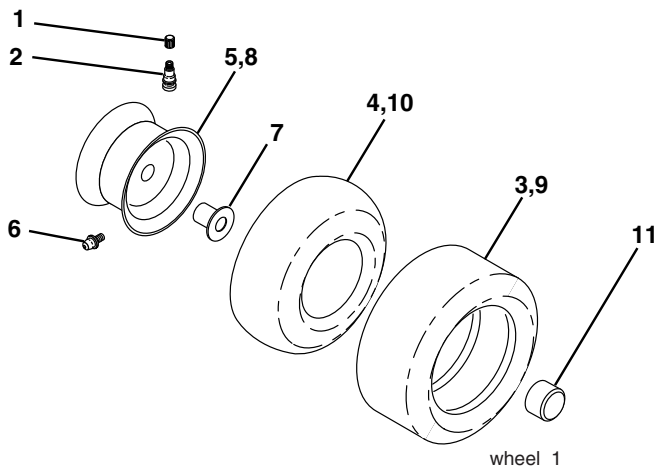

KEY NO.	PART NO.	DESCRIPTION
1	532 05 91-92	Cap Valve Tire
2	532 06 51-39	Stem Valve
3	532 10 62-22	Tire F Ts 15 x 6.0 - 6 Service
4	532 05 99-04	Tube Front (Service Item Only)
5	532 12 51-21	Rim Asm 6" front Service
6	532 12 49-57	Fitting Grease (Front Wheel Only)
7	532 12 49 59	Bearing Flange (Front Wheel Only)
8	532 12 51-22	Rim Asm 8" rear Service
9	532 13 84-68	Tire R Ts 20 x 8-8 C Service
10	532 00 72-51	Tube Rear (Service Item Only)
11	532 19 32-68	Cap Axle
--	532 14 43-34	Sealant, Tire (10 oz. Tube)

NOTE: All component dimensions given in U.S. inches
1 inch = 25.4 mm

REPAIR PARTS

TRACTOR - - MODEL NO. PP18542 (96011021600), PRODUCT NO. 960 11 02-16
ELECTRICAL

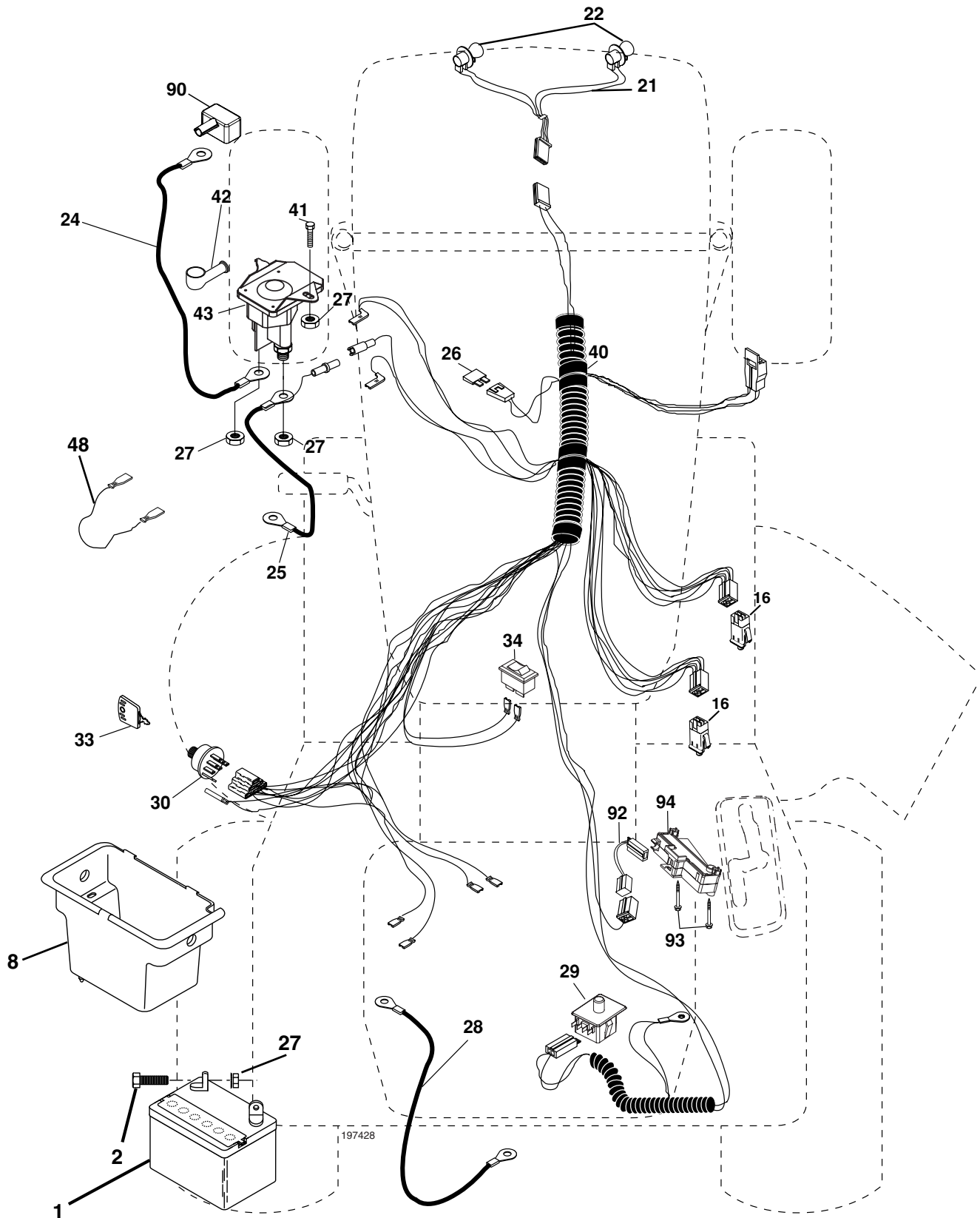

REPAIR PARTS

TRACTOR - - MODEL NO. PP18542 (96011021600), PRODUCT NO. 960 11 02-16
ELECTRICAL

KEY NO.	PART NO.	DESCRIPTION
1	532 16 34-65	Battery
2	874 76 04-12	Bolt Hex Hd 1/4-20 unc x 3/4
8	532 17 66-89	Box Battery
16	532 17 61-38	Switch Interlock
21	532 18 37-59	Harness Asm Light W/4152j
22	532 00 41-52	Bulb Light #1156
24	532 00 44-79	Cable Battery 6 Ga. 11" red
25	532 14 61-47	Cable Battery 6 Ga. 44" red w/16 wire
26	532 17 51-58	Fuse
27	873 51 04-00	Nut Keps Hex 1/4-20 unc
28	532 12 47-73	Cable Ground 6 Ga. 12" black
29	532 19 27-49	Switch Seat
30	532 19 33-50	Switch Ign Delta
33	532 14 04-01	Key Ign Molded Generic
34	532 11 07-12	Switch Light/Reset B/B /Red
40	532 19 74-28	Harness Ign.
41	871 11 04-08	Bolt Blk Fin Hex 1/4 - 20 x 1/2
42	532 13 15-63	Cover Terminal Red
43	532 19 25-07	Solenoid
45	532 14 08-44	Ammeter Adapter
90	532 18 04-49	Cover Terminal Battery
92	532 19 66-15	Harness Pigtail consle ROS
93	532 19 25-40	Screw Plastite 10-14 x 2.0
94	532 19 18-34	Module Reverse ROS

NOTE: All component dimensions given in U.S. inches.
1 inch = 25.4 mm.

REPAIR PARTS

TRACTOR - - MODEL NO. PP18542 (96011021600), PRODUCT NO. 960 11 02-16
CHASSIS AND ENCLOSURES

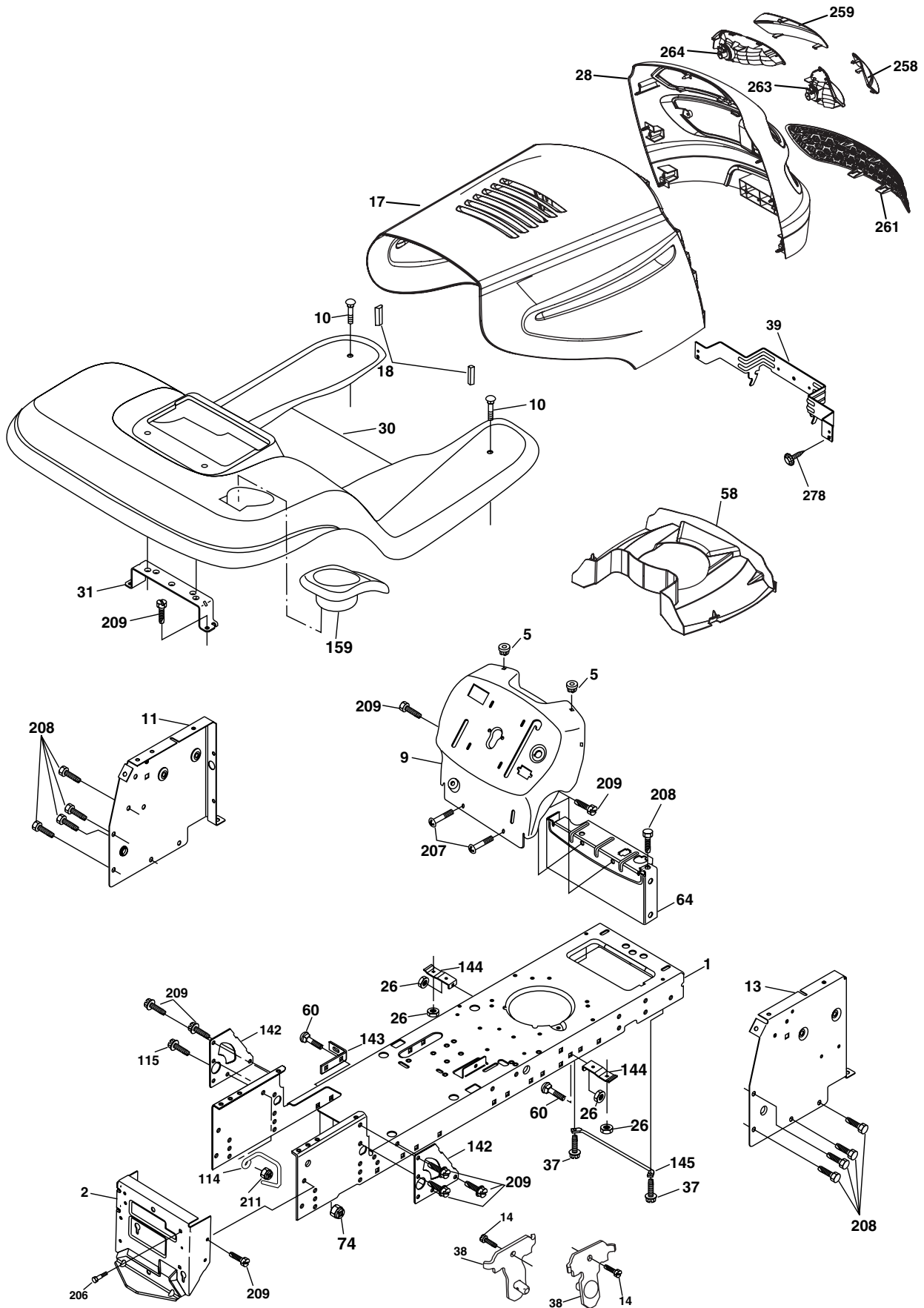

REPAIR PARTS

TRACTOR - - MODEL NO. PP18542 (96011021600), PRODUCT NO. 960 11 02-16
CHASSIS AND ENCLOSURES

KEY NO.	PART NO.	DESCRIPTION
1	532 17 46-19	Chassis Stamping
2	532 17 65-54	Drawbar
5	532 15 52-72	Bumper
9	532 40 51-14	Dash
10	872 14 06-08	Bolt Rdhd Sqnk 3/8-16 unc x 1
11	532 17 49-96	Panel Dash Lh
13	532 18 69-52	Panel Dash Rh
14	817 49 06-08	Screw Thdrol 3/8-16 x 1/2
17	532 18 65-80	Hood
18	532 18 49-21	Bumper Hood
26	873 80 06-00	Nut Lock w/Insert 3/8-16 unc
28	532 18 38-28	Grille Lens Asm (Includes Key Nos. 258, 259, 261, 263 and 264)
30	532 19 58-09	Fender
31	532 13 99-76	Bracket
37	817 49 05-08	Screw Thdrol 5/16-18 x 1/2
38	532 17 57-10	Bracket Asm Pivot Mower Rear
39	532 17 47-14	Bracket Pivot Hood
58	532 15 01-27	Duct Air
60	872 14 06-06	Bolt RDHD SQNK 3/8-16 x 3/4
64	532 15 47-98	Dash Lower Stlt
74	873 68 06-00	Nut Crownlock 3/8-16
114	532 15 81-12	Keeper Belt Rear
115	817 49 06-20	Screw Thdrol 3/8-16 x 1-1/4
142	532 17 57-02	Plate Reinforcement Stlt
143	532 18 66-89	Bracket Swaybar Chassis
144	532 17 55-82	Bracket Ft Rest
145	532 15 65-24	Rod Pivot Chassis Hood
159	532 18 13-55	Cupholder
206	532 17 01-65	Bolt Shoulder 5/16-18 TT
207	817 67 05-08	Screw Thdrol 5/16-18 x 1/2 TYTT
208	817 67 06-08	Screw Thdrol 3/8-16 x 1/2 TY-TT
209	817 00 06-12	Screw 3/8-16 x 3/4
211	532 14 52-12	Nut Hexflange Lock
258	532 18 97-55	Lens RH
259	532 18 97-54	Lens LH
261	532 18 97-53	Insert, Grille
263	532 18 38-33	Bezel RH
264	532 18 38-32	Bezel LH
278	532 19 16-11	Screw 10 x 3/4 Single Lead-Hex
--	532 00 54-79	Plug
--	532 18 78-01	Plug Dome Plastic (Choke Hole)

NOTE: All component dimensions given in U.S. inches
1 inch = 25.4 mm

REPAIR PARTS

TRACTOR - - MODEL NO. PP18542 (96011021600), PRODUCT NO. 960 11 02-16
DRIVE

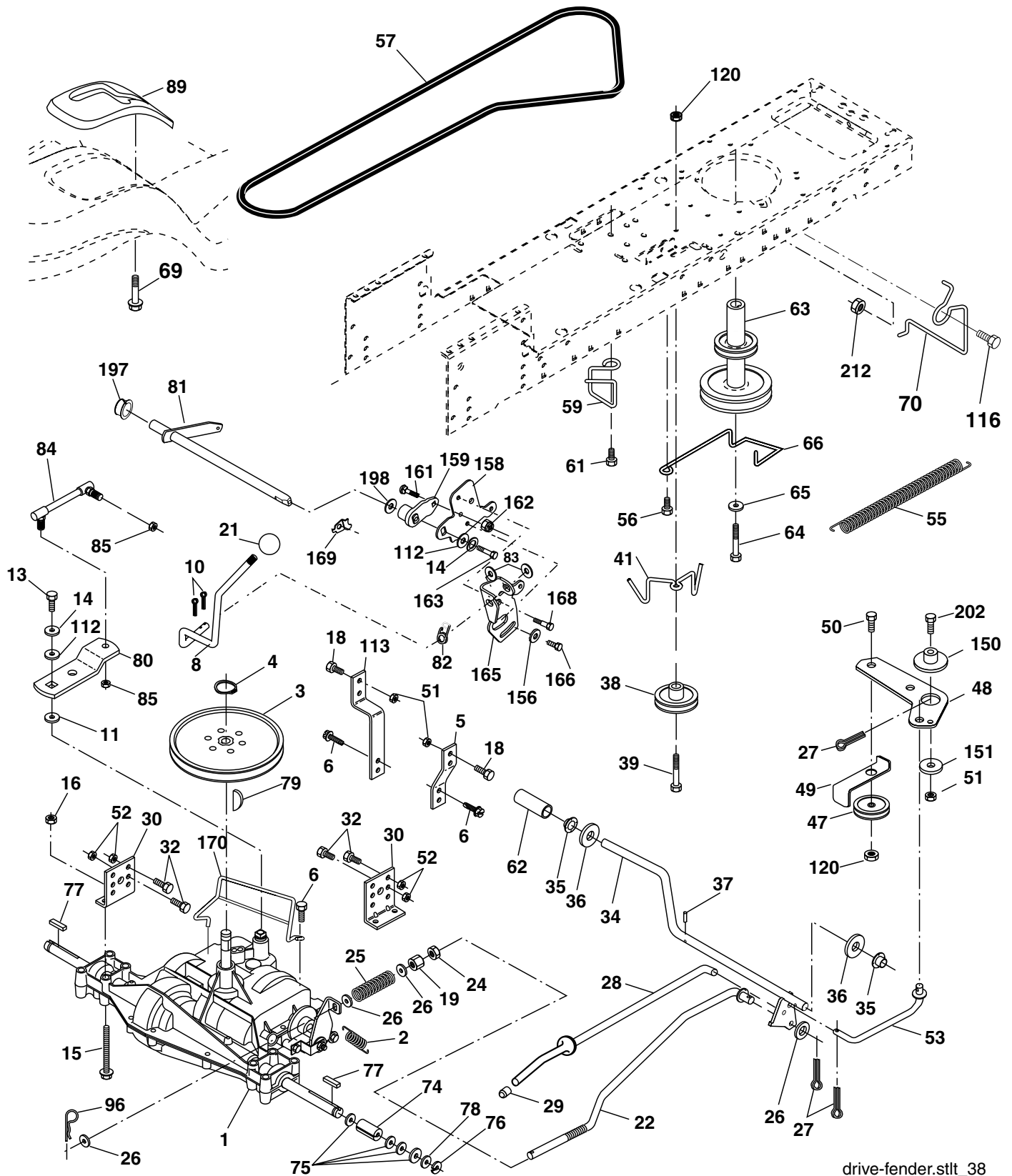

drive-fender.stlt_38

REPAIR PARTS

**TRACTOR - - MODEL NO. PP18542 (96011021600), PRODUCT NO. 960 11 02-16
DRIVE**

KEY NO.	PART NO.	DESCRIPTION	KEY NO.	PART NO.	DESCRIPTION
1	-----	Transaxle, Peerless 206-545C (Order Parts From Transaxle Manufacturer)	62	532 00 88-83	Cover Pedal
2	532 14 66-82	Spring Return Brake T/a Zinc	63	532 17 54-10	Engine Pulley LT/YT
3	532 12 36-66	Pulley Transaxle 18" tires	64	532 17 39-37	Bolt Hex
4	812 00 00-28	Ring Retainer # 5100-62	65	810 04 07-00	Washer Lock Hvy Hlcl Spr 7/16
5	532 12 15-20	Strap Torque 30 Degrees	66	532 15 47-78	Keeper Belt Engine Foolproof
6	817 06 05-12	Screw Thdrol 5/16-18 x 3/4 TYT	69	532 14 24-32	Screw Hex Wsh Hi-Lo 1/4-1/2 unc
8	532 19 25-02	Rod Shift Fender Adjust STLT	70	532 13 46-83	Guide Belt Mower Drive RH
10	876 02 04-16	Pin Cotter 1/8 x 1 Cad	74	532 13 70-57	Spacer Axle
11	532 10 57-01	Washer Plate Shf 388 Sq Hole	75	532 12 17-49	Washer 25/32 x 1 1/4 x 16 Ga.
13	874 55 04-12	Bolt 1/4-28 unf Gr. 8 W/Patch	76	812 00 00-01	E-ring #5133-75
14	810 04 04-00	Washer Lock Hvy Helical 1/4	77	532 12 35-83	Key Square 2 0 x 1845/ 1865
15	874 49 05-44	Bolt 5/16-18 Gr. 5	78	532 12 17-48	Washer 25/32 x 1-5/8 x 16 Ga.
16	873 80 05-00	Nut Lock Hx W/lins 5/16-18 unc Pl	79	532 12 50-96	Key Woodruff #9 3/16 x 3/4
18	874 78 06-16	Bolt, Fin Hex 3/8-16 unc x 1 Gr. 5	80	532 14 50-90	Arm Shift
19	873 80 06-00	Nut Lock 3/8-16 unc	81	532 16 55-92	Shaft Asm Cross Tapered
21	532 10 62-79	Knob	82	532 16 57-11	Spring Torsion T/a
22	532 13 08-04	Rod Brake Blk Zinc 26 840	83	819 17 12-16	Washer 17/32 x 3/4 x 16 Ga.
24	873 35 06-00	Nut Hex Jam 3/8-16 unc	84	532 16 62-31	Transaxle Link
25	532 10 68-88	Spring Rod Brake 2 00 Zinc	85	532 15 03-60	Nut Lock Center 1/4 - 28 FNTHD
26	819 13 13-16	Washer 13/32 x 13/16 x 16 Ga	89	532 19 53-94	Console Shift STLT
27	876 02 04-12	Pin Cotter 1/8 x 3/4 Cad	96	532 12 47-88	Retainer Spring 1"
28	532 17 57-65	Rod Brake Parking LT/YT	112	819 09 12-10	Washer 9/32 x 3/4 x 10 Ga.
29	532 07 16-73	Cap Brake Parking Black	113	532 12 72-85	Strap Torque LT
30	532 16 95-92	Bracket Mtg Transaxle	116	872 14 06-08	Bolt Rdhd Sq Neck 3/8-16 x 1
32	874 76 05-12	Bolt Hex Hd 5/16-18 unc x 3/4	120	873 90 06-00	Nut Lock Flg. 3/8-16
34	532 17 55-78	Shaft Asm Pedal Foot	150	532 17 54-56	Spacer Retainer
35	532 12 01-83	Bearing Nylon Blk 629 Id	151	819 13 32-10	Washer 13/32 x 2 x 10 Ga.
36	819 21 16-16	Washer 21/32 x 1 x 16 Ga	156	532 16 60-02	Washer Srrted 5/16 ID x 1.125
37	532 00 15-72	Pin Roll 3/16 x 1"	158	532 16 55-89	Bracket Shift Mount
38	532 17 91-14	Pulley Composite	159	532 18 39-00	Hub Shift
39	872 11 06-22	Bolt Rdhd 3/8-16 x 2-3/4 Gr. 5	161	872 14 04-06	Bolt Rdhd Sqnk 1/4-20 x 3/4 Gr. 5
41	532 17 55-56	Keeper Belt Idler Flat	162	873 68 04-00	Nut Crownlock 1/4-20 unc
47	532 12 77-83	Pulley Idler V Groove Plastic	163	874 78 04-16	Bolt Hex Fin 1/4-20 unc x 1 Gr. 5
48	532 15 44-07	Bellcrank Clutch Grnd Drv Stl	165	532 16 56-23	Bracket Pivot Lever
49	532 12 32-05	Retainer Belt Style Spring	166	817 49 05-10	Screw 5/16-18 x 5/8
50	872 11 06-12	Bolt Carr. sh 3/8-16 x 1-1/2 Gr. 5	168	532 16 54-92	Bolt Shoulder 5/16-18 x .561
51	873 68 06-00	Nut Crownlock 3/8-16 unc	169	532 16 55-80	Plate Fastening STLT/CRD
52	873 68 05-00	Nut Crownlock 5/16-18 unc	170	532 18 74-14	Keeper Belt T/A
53	532 19 96-52	Link Clutch	197	532 16 96-13	Nyliner Snap-In 5/8" ID
55	532 10 57-09	Spring Return Clutch 6 75	198	532 16 95-93	Washer Nyl 7/8 Id x .105" Hyd
56	817 06 06-20	Screw 3/8-16 x 1-1/4	202	872 11 06-14	Bolt 3/8-16 x 1-3/4 Gr 5
57	532 13 82-55	V-Belt Ground Drive	212	532 14 52-12	Nut Hex Flg Lock
59	532 16 96-91	Keeper Belt Span Ctr			
61	817 12 06-14	Screw 3/8-16 x .875			

NOTE: All component dimensions give in U.S. inches.
1 inch = 25.4 mm.

REPAIR PARTS

TRACTOR - - MODEL NO. PP18542 (96011021600), PRODUCT NO. 960 11 02-16
STEERING ASSEMBLY

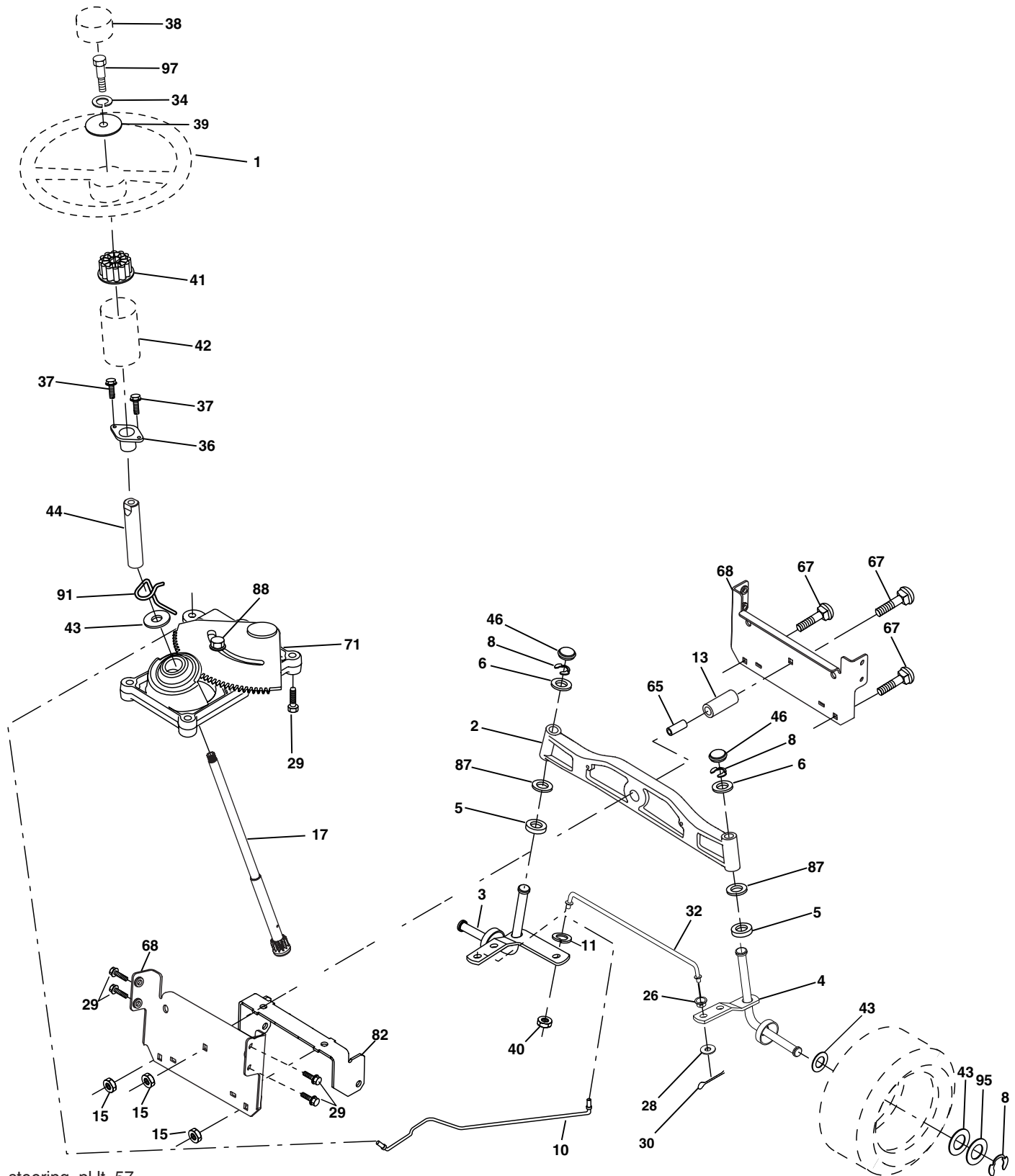

steering_pl.lt_57

REPAIR PARTS

TRACTOR - - MODEL NO. PP18542 (96011021600), PRODUCT NO. 960 11 02-16
STEERING ASSEMBLY

KEY NO.	PART NO.	DESCRIPTION
1	532 19 45-95	Wheel Steering
2	532 18 47-06	Axle Asm
3	532 16 98-40	Spindle Asm LH
4	532 16 98-39	Spindle Asm RH
5	532 00 62-66	Bearing Race Thrust Harden
6	532 12 17-48	Washer 25/32 x 1-5/8 x 16 Ga.
8	812 00 00-29	Ring Klip #t5304-75
10	532 17 51-21	Link Drag
11	810 04 06-00	Washer Lock Hvy Hlcl Spr 3/8
13	532 13 65-18	Spacer Brg Axle Front
15	532 14 52-12	Nut Hex Flange Lock
17	532 19 07-53	Shaft Asm Strg
26	532 12 68-47	Bushing Link Drag Blk LR
28	819 13 14-16	Washer 13/32 x 7/8 x 16 Ga.
29	817 00 06-12	Screw 3/8-16 x 3/4
30	876 02 04-12	Pin Cotter 1/8 x 3/4 Cad
32	532 19 27-57	Rod Tie Wire Form
34	810 04 05-00	Washer Lock Hvy Hlch Spr. 5/16
36	532 15 50-99	Bushing Strg
37	532 15 29-27	Screw
38	532 19 46-03	Cap Wheel Steering
39	819 11 38-12	Washer 11/32 ID x 2-3/8 OD 12 Ga.
40	873 54 06-00	Lock nut
41	532 18 67-37	Adaptor Wheel Strg
42	532 16 96-33	Boot Steering Shaft
43	532 12 17-49	Washer 25/32 x 1 1/4 x 16 Ga.
44	532 19 07-52	Extension Steering Shaft LR/LT
46	532 12 12-32	Cap Spindle Fr Top Blk
65	532 16 03-67	Spacer Brace Axle
67	872 11 06-18	Bolt Rdhd Sq 3/8-16 x 2-1/4
68	532 16 98-27	Axle, Brace
71	532 17 51-46	Steering Asm
82	532 19 99-78	Bracket Susp Chassis Front
88	532 17 51-18	Bolt Shoulder 7/16-20
87	532 17 39-66	Washer Flat .781 x 1-1/2 x .14
91	532 17 55-53	Clip Steering
95	532 18 89-67	Washer Hardened
97	874 78 05-64	Bolt 5/16-18 unc x 4" L Gr. 5

NOTE: All component dimensions given in U.S. inches.
1 inch = 25.4 mm.

REPAIR PARTS

TRACTOR - - MODEL NO. PP18542 (96011021600), PRODUCT NO. 960 11 02-16
SEAT ASSEMBLY

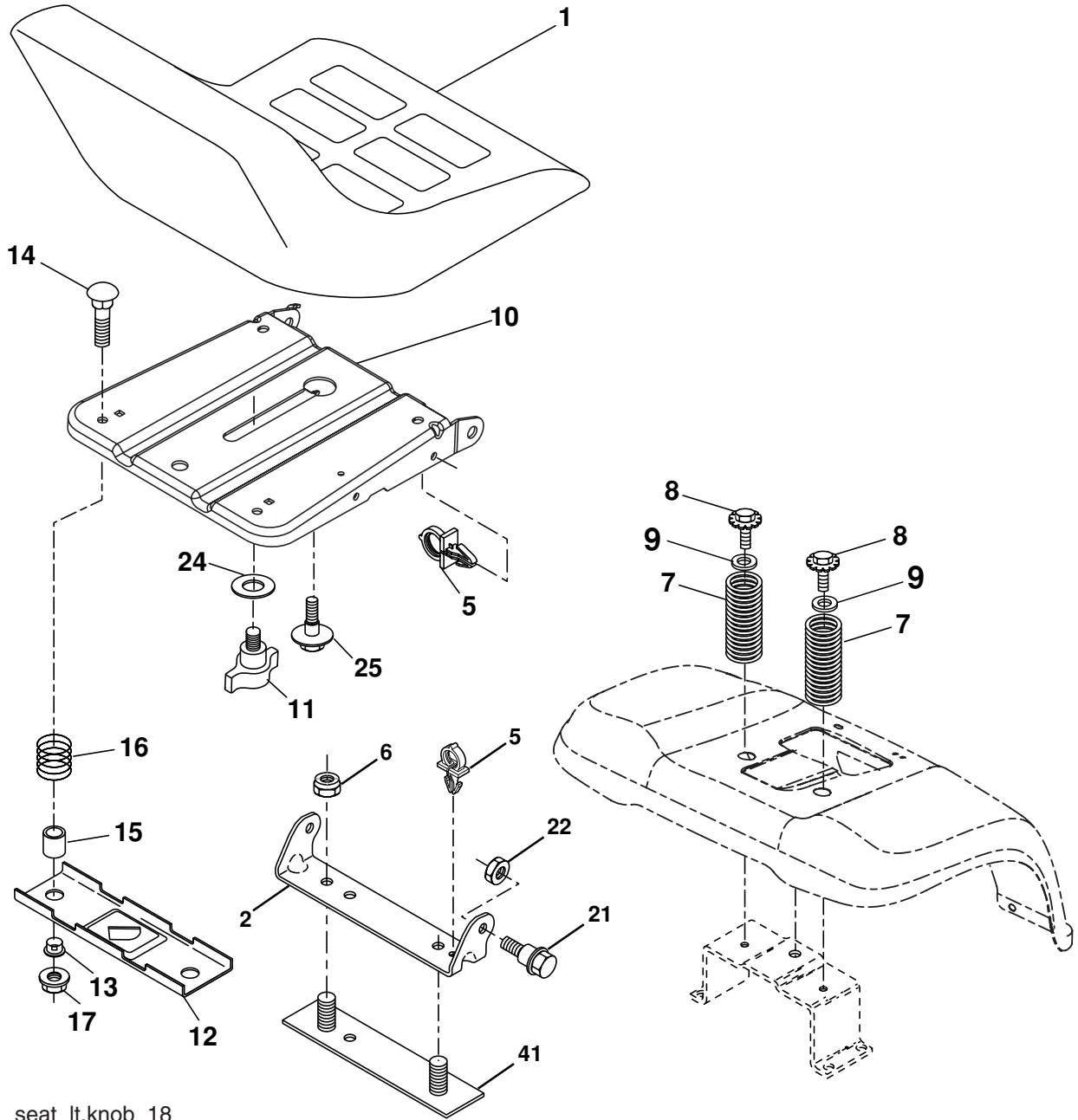

KEY NO.	PART NO.	DESCRIPTION
1	532 18 87-12	Seat
2	532 14 05-51	Bracket Pivot Seat
5	532 14 50-06	Clip Push-In
6	873 80 06-00	Nut Hex w/Ins. 3/8-16 unc
7	532 12 41-81	Spring Seat Cprsn 2 250 Blk Zi
8	817 00 06-16	Screw 3/8-16 x 1
9	819 13 16-14	Washer 13/32 x 1 x 14 Ga.
10	532 19 55-30	Pan Seat
11	532 16 63-69	Knob Seat
12	532 17 46-48	Bracket Mounting Switch
13	532 12 12-48	Bushing Snap Blk Nyl 50 Id

KEY NO.	PART NO.	DESCRIPTION
14	872 05 04-12	Bolt Rdhd Sqnk 1/4-20 x 1-1/2
15	532 13 43-00	Spacer Split 28 x 96 Yel Zinc
16	532 12 12-50	Spring Cprsn 1 27 Blk Pnt
17	532 12 39-76	Nut Lock 1/4 Lge Flg Gr. 5 Zinc
21	532 17 18-52	Bolt Shoulder 5/16-18 unc-2A
22	873 80 05-00	Nut Hex Lock W/Ins 5/16-18
24	819 17 19-12	Washer 17/32 x 1-3/16 x 12 Ga.
25	532 12 70-18	Bolt Shoulder 5/16 - 18 X .62
41	532 14 06-75	Strap Asm. Fender

NOTE: All component dimensions given in U.S. inches.
1 inch = 25.4 mm

REPAIR PARTS

TRACTOR - - MODEL NO. PP18542 (96011021600), PRODUCT NO. 960 11 02-16
MOWER LIFT

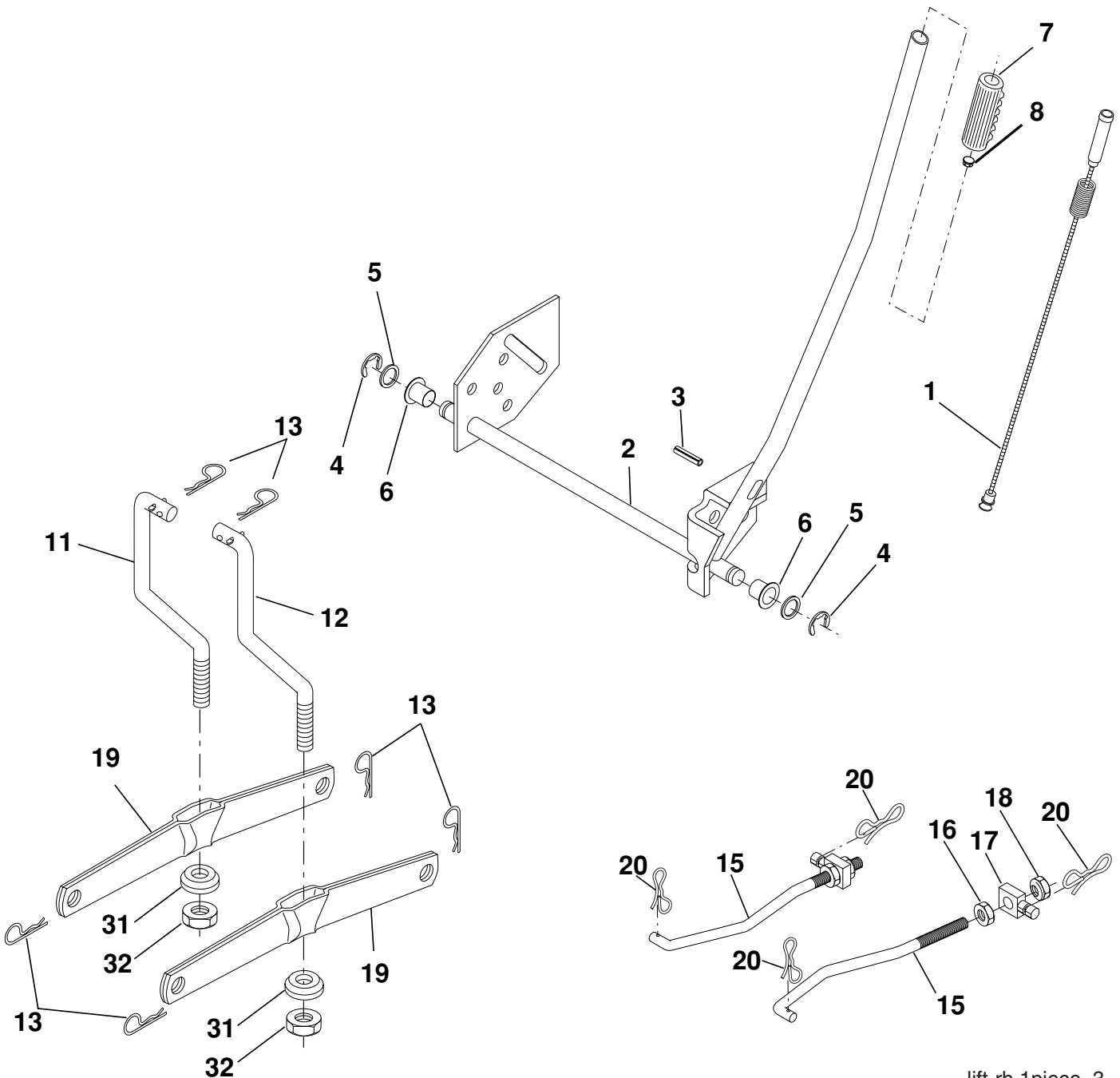

lift-rh.1piece_3

KEY NO.	PART NO.	DESCRIPTION
1	532 19 84-17	Wire Asm Inner W/plunger LT
2	532 19 80-70	Shaft Asm Lift
3	532 18 88-22	Pin Groove
4	812 00 00-02	E Ring #5133-62
5	819 21 16-21	Washer PLTD 21/32 x 1 x 21 Ga.
6	532 12 01-83	Bearing Nylon Blk 629 Id
7	532 12 56-31	Grip Handle
8	532 17 07-70	Button Plunger Yellow
11	532 13 98-65	Link Lift LH
12	532 13 98-66	Link Lift RH
13	532 12 46-70	Retainer Spring

KEY NO.	PART NO.	DESCRIPTION
15	532 17 32-88	Link Front
16	873 35 08-00	Nut Jam Hex 1/2-13 unc
17	532 17 56-89	Trunnion
18	873 80 08-00	Nut Lock W/Wsh 1/2-13 unc
19	532 13 98-68	Arm Suspension Rear
20	532 19 42-09	Pin Cotter 7/16 Bow Tie Lock
31	532 16 98-65	Bearing Pvt. Lift
32	873 54 06-00	Nut Crownlock 3/8-24

NOTE: All component dimensions given in U.S. inches
1 inch = 25.4 mm

REPAIR PARTS

TRACTOR - - MODEL NO. PP18542 (96011021600), PRODUCT NO. 960 11 02-16
MOWER DECK

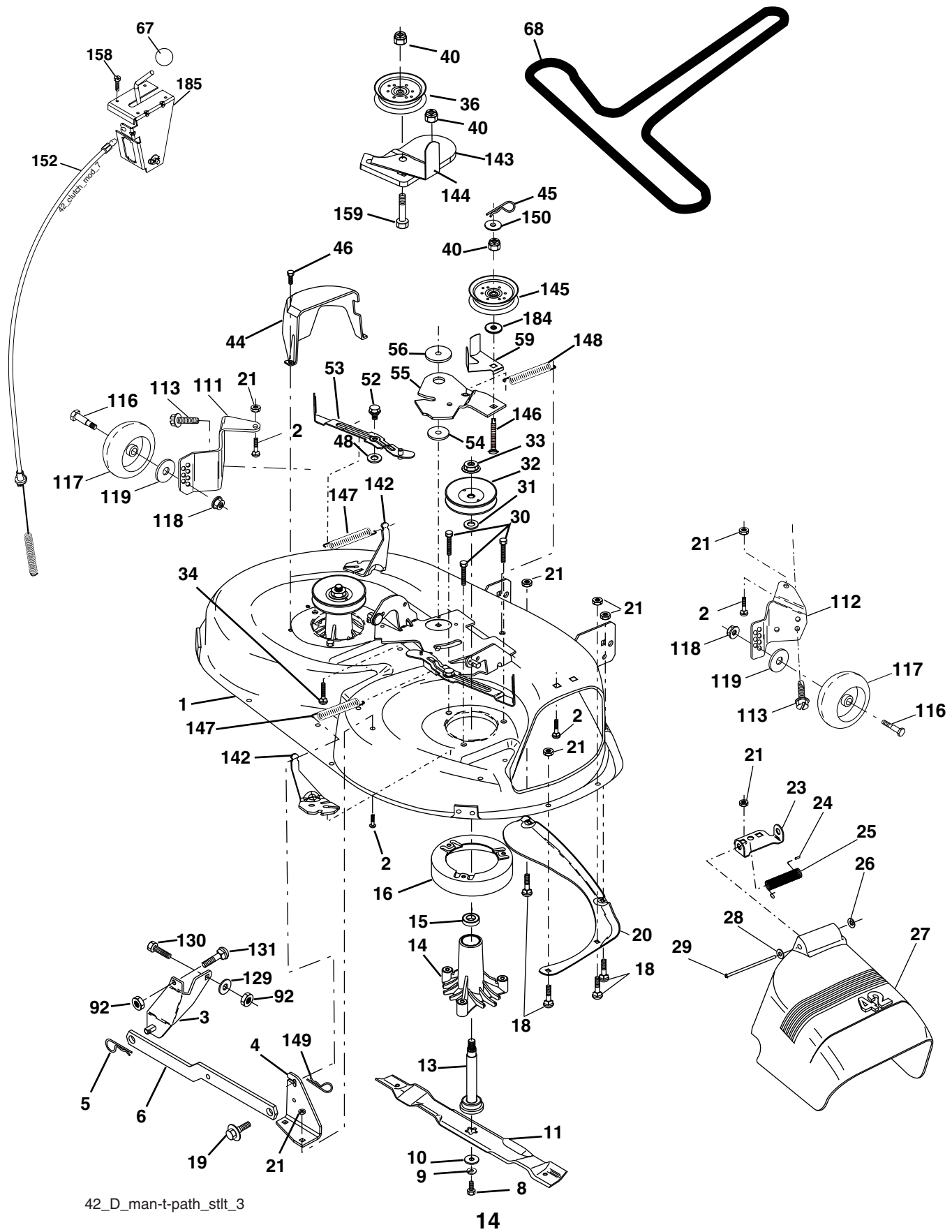

REPAIR PARTS

**TRACTOR - - MODEL NO. PP18542 (96011021600), PRODUCT NO. 960 11 02-16
MOWER DECK**

KEY NO.	PART NO.	DESCRIPTION	KEY NO.	PART NO.	DESCRIPTION
1	532 16 58-92	Deck Asm MWR 42"weldment	67	532 17 15-98	Knob
2	872 14 05-06	Bolt Rdhd Sqnk 5/16-18 unc x 3/4	68	532 14 49-59	V-Belt Mower 42"
3	532 13 80-17	Bracket Asm Fr Sway Bar 38/42	92	873 80 06-00	Nut 3/8-16 unc
4	532 16 54-60	Bracket Asm Deck 42"sway Bar	111	532 17 92-92	Bracket Wheel Guage LH
5	532 12 46-70	Retainer Spring	112	532 17 92-93	Bracket Wheel Guage RH
6	532 17 80-24	Deck Sway Bar	113	817 00 05-10	Bolt 5/16-18 Hex Whs-Hd Lck Ser.
8	532 85 08-57	Bolt 3/8 - 24 x 1.25 Gr. 8	116	532 00 48-98	Bolt Shoulder
9	810 03 06-00	Washer Lock Hvy 3/8	117	532 18 86-06	Wheel Guage
10	532 14 02-96	Washer Hard Blade Mower Vented	118	873 93 06-00	Nut Lock 3/8-16 unc
11	532 13 89-71	Blade Mower 42"	119	819 12 14-14	Washer 3/8 x 7/8 x 14 Ga.
13	532 13 76-45	Shaft Asm W/lower Bearing	129	819 13 13-12	Washer 13/32 x 13/16 x 12 Ga.
14	532 12 87-74	Housing Mandrel Vented	130	874 78 06-16	Bolt 3/8-16 x 1 Gr. 5
15	532 11 04-85	Bearing Ball Mandrel	131	872 14 06-08	Bolt 3/8-16 x 1
16	532 17 44-93	Stripper Mower	142	532 16 58-90	Arm Spring Brake Mower
18	872 14 05-05	Bolt Rdhd Sqnk 5/16-18 x 5/8	143	532 15 71-09	Bracket Arm Idler 42"
19	532 13 28-27	Bolt Shoulder	144	532 17 34-41	Keeper Belt 42" Clutch
20	532 15 97-70	Baffle Vortex 42	145	532 17 34-37	Pulley Idler Flat
21	873 68 05-00	Nut Crownlock 5/16-18 unc	146	532 17 34-43	Bolt Carriage Idler
23	532 17 75-63	Bracket Deflector Mower 42"	147	532 13 13-35	Spring Extension
24	532 10 53-04	Cap Sleeve 80 x 112 Blk Mower	148	532 16 90-22	Spring Return Idler
25	532 12 37-13	Spring Torsion Deflector 2 52	149	532 16 58-98	Retainer Spring Yellow
26	532 11 04-52	Nut Push Phos & Oil	150	819 09 12-10	Washer 9/32 x 3/4 x 10 Ga.
27	532 17 18-59	Shield Deflector Mower 42" Blk	152	532 16 96-76	Clutch Cable 42"
28	819 11 10-16	Washer 11/32 x 5/8 x 16 Ga.	158	817 72 04-08	Screw Hex Thd Cut 1/4-20 x 1/2
29	532 13 14-91	Rod Hinge 42" 6 75 Wlg	159	872 14 06-14	Bolt Rdhd Sqn 3/8-16 unc x 1-3/4
30	532 17 39-84	Screw Thd Rolling	184	819 13 14-10	Washer 13/32 x 7/8 x 10 Ga.
31	532 18 76-90	Washer Spacer	185	532 18 82-34	Head Asm. Cable Clutch
32	532 17 34-36	Pulley Mandrel 42"	--	532 13 07-94	Mandrel Assembly(Includes Housing, Shaft and Shaft Hardware Only-Pulley not Included)
33	532 40 02-34	Nut Toplock Fling	--	532 17 25-59	Replacement Mower, Complete (Std. Deck - Order separately gauge wheel and mulch cover components key nos. 116-119 and 101-106)
34	872 11 06-12	Bolt Rdhd 3/8-16 unc x 1-1/2 Gr. 5			
36	532 17 34-38	Pulley Idler Flat			
40	873 90 06-00	Nut Lock 3/8-16 unc			
44	532 14 00-88	Guard Mandrel LH Black			
45	532 00 44-97	Spring Retainer 1" Zinc/cad			
46	532 13 77-29	Screw Hex Thd Cut 1/4-20 x 5/8 T			
48	532 13 39-44	Washer Hardened Smaller			
52	532 13 98-88	Bolt Shoulder 5/16-18 unc Blkz			
53	532 18 49-07	Arm Asm Pad Brake			
54	532 17 85-15	Washer Hardened			
55	532 15 50-46	Arm Idler 42"mower LT/YT			
56	532 12 20-52	Spacer Retainer Mower			
59	532 14 10-43	Guard TUV Idler			

NOTE: All component dimensions given in U.S. inches
1 inch = 25.4 mm

REPAIR PARTS

SERVICE NOTES

TRACTOR - - MODEL NO. PP18542 (96011021600), PRODUCT NO. 960 11 02-16
ENGINE

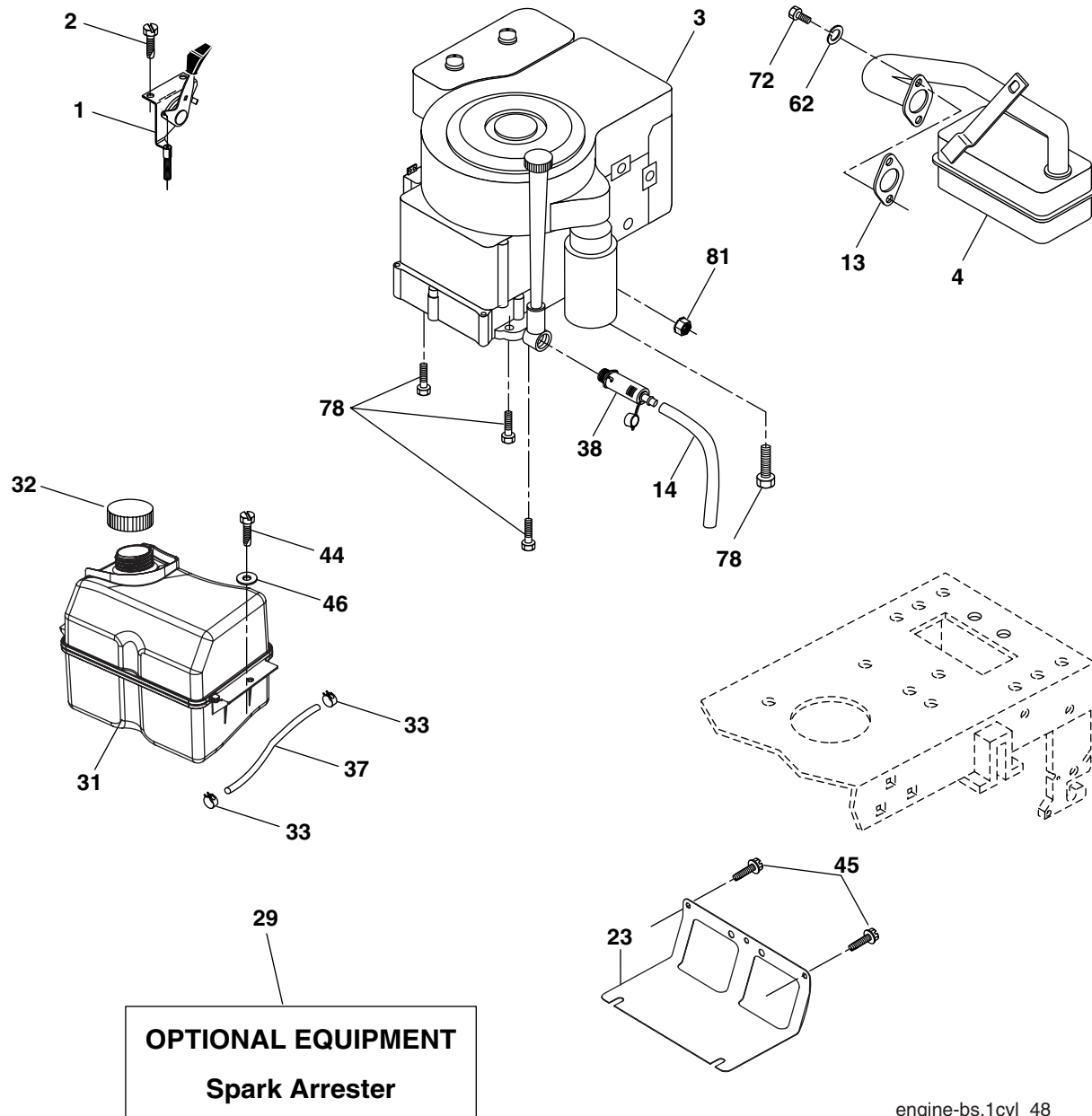

engine-bs.1cyl_48

KEY NO.	PART NO.	DESCRIPTION
1	532 17 05-51	Control Throttle/Choke
2	817 72 04-08	Screw Hex Thd Cut 1/4-20 x 1/2
3	-----	Engine, Briggs 31P777 (Order parts from engine manufacturer)
4	532 13 73-52	Muffler
13	532 16 52-91	Gasket Eng
14	532 14 84-56	Tube Drain Oil Easy
23	532 16 98-37	Shield Brn/Dbr Guard
29	532 13 71-80	Kit Spark Arrestor (Flat Scrn)
31	532 18 55-34	Tank Fuel
32	532 19 77-25	Cap Asm Fuel Top
33	532 12 34-87	Clamp Hose Black

KEY NO.	PART NO.	DESCRIPTION
37	532 13 70-40	Line Fuel 20"
38	532 18 16-54	Plug Drain Oil Easy
44	817 67 04-12	Screw Hexwsh Thdrol 1/4-20 x 3/4
45	817 00 06-12	Screw Hexwsh Thdr 3/8-16 x 3/4
46	819 09 14-16	Washer 9/32 x 7/8 x 16 Ga.
62	810 01 05-00	Washer Split
72	532 19 23-34	Screw Socket Hd 5/16-18 x .75
78	817 06 06-20	Screw 3/8-16 x 1-1/4 SMGML
81	873 51 04-00	Nut Keps Hex 1/4-20 unc

NOTE: All component dimensions given in U.S. inches
1 inch = 25.4 mm